

MarkingMate

TABLE OF CONTENTS

CHAPTER 1 SYSTEM INSTALLATION.....	5
1.1 INSTALLATION NOTICE	5
1.2 MARKINGMATE INSTALLATION	6
1.3 HARDWARE PROTECT KEY INSTALLATION	9
CHAPTER 2 QUICK GUIDE TO NEWCOMERS	10
2.1 START PROGRAM.....	10
2.1.1 User Interface	11
2.2 READ FILES	12
2.2.1 Open	12
2.2.2 Import.....	12
2.2.3 Draw.....	14
2.3 PARAMETERS SETTINGS.....	15
2.3.1 Position Adjustments	15
2.3.2 Marking Parameters	18
2.4 EXECUTE MARK	23
2.5 OPERATION EXAMPLES.....	24
2.5.1 Import DXF File	24
2.5.2 Auto Text.....	28
2.5.3 Combine/Break.....	42
2.5.4 Group/UnGroup.....	44
2.5.5 Sort.....	46
2.5.6 Rotary Axis Marking (optional).....	47
CHAPTER 3 LASER MARKING FUNCTION INTRODUCTION	50
3.1 SYSTEM DIAGRAM.....	50
3.1.1 Composition Function.....	50
3.1.2 Object Path Arrangement and Control.....	51
3.1.3 Laser Source Control.....	52
3.2 AUTOMATION AND I/O	60
3.2.1 MarkingMate Signal Time Sequence	60
3.2.2 Error Messages Planning	64
CHAPTER 4 MENU BAR.....	67
4.1 FILE MENU	67
4.1.1 New	68
4.1.2 Open	68
4.1.3 Close.....	68
4.1.4 Save.....	69
4.1.5 Save As	69
4.1.6 Option	70
4.1.7 Import.....	76
4.1.8 Export DXF	77
4.1.9 Select TWAIN Device.....	77
4.1.10 TWAIN Acquire	78
4.1.11 Config Import/Export	78
4.1.12 Print.....	80
4.1.13 Preview.....	80
4.1.14 Printer setting	81
4.1.15 Exit	81
4.2 EDIT MENU.....	82
4.2.1 Redo.....	83
4.2.2 Undo.....	83
4.2.3 Cut.....	83
4.2.4 Copy.....	83
4.2.5 Paste.....	83

MarkingMate

4.2.6 Delete.....	84
4.2.7 Combine.....	84
4.2.8 Break.....	84
4.2.9 Group.....	84
4.2.10 UnGroup.....	85
4.2.11 Sort.....	85
4.2.12 Mirror Horizontal.....	85
4.2.13 Mirror Vertical.....	86
4.2.14 Baseline.....	86
4.2.15 Split.....	87
4.2.16 Trans-Curve.....	87
4.2.17 Trim.....	88
4.2.18 Jump Cross.....	88
4.2.19 Welding.....	89
4.2.20 Contour.....	89
4.2.21 Transfer to Image.....	90
4.2.22 Align.....	91
4.2.23 Distribute.....	91
4.3 DRAW MENU.....	92
4.3.1 Selection.....	93
4.3.2 Line.....	93
4.3.3 Arc.....	94
4.3.4 Circle.....	94
4.3.5 Rectangle.....	96
4.3.6 Curve.....	97
4.3.7 Curve Brush.....	97
4.3.8 Text.....	98
4.3.9 Arc Text.....	99
4.3.10 1D Barcode.....	100
4.3.11 2D Barcode.....	101
4.3.12 Control.....	102
4.4 IMAGE MENU.....	106
4.4.1 Effects.....	107
4.4.2 Special Filters.....	113
4.5 COLOR MENU.....	119
4.5.1 Gray Scale.....	120
4.5.2 Color Resolution.....	120
4.5.3 Brightness.....	121
4.5.4 Contrast.....	121
4.5.5 Hue.....	122
4.5.6 Saturation.....	123
4.5.7 Gamma Correct.....	124
4.5.8 Intensity.....	125
4.5.9 Histogram.....	125
4.5.10 Invert.....	126
4.5.11 Solarize.....	126
4.6 EXECUTE MENU.....	128
4.6.1 Marking.....	129
4.6.2 Quick Mark.....	137
4.6.3 Align Test.....	137
4.6.4 User Level.....	138
4.6.5 Mark Parameter List.....	139
4.6.6 Rotary Marking.....	141
4.7 VIEW MENU.....	142
4.7.1 Standard Bar.....	143
4.7.2 Zoom Bar.....	143
4.7.3 Draw Bar.....	144
4.7.4 Layer Bar.....	144
4.7.5 Object Browser.....	145
4.7.6 Modify Bar.....	145

MarkingMate

4.7.7 Dimension Bar	146
4.7.8 Object Property Bar	146
4.7.9 Control Object	148
4.7.10 Laser Mark	148
4.7.11 Laser Panel (optional)	152
4.7.12 Status Bar	152
4.7.13 Welcome	152
4.7.14 Composing Setting	152
4.7.15 Zoom In	155
4.7.16 Zoom Out	155
4.7.17 Zoom Previous	155
4.7.18 Zoom All	155
4.7.19 Zoom Extend	155
4.7.20 Show Hatch Line	155
4.8 WINDOW MENU	157
4.9 HELP MENU	159
CHAPTER 5 OBJECTS	160
5.1 COMMON SETTINGS	160
5.1.1 Property Table	160
5.1.2 Popup Menu	161
5.2 CREATE OBJECTS	162
CHAPTER 6 PROPERTY TABLE	163
6.1 SYSTEM-RELATED	164
6.1.1 Lens	164
6.1.2 Driver	168
6.1.3 Global	169
6.1.4 Power Test	172
6.1.5 Motor Setup (optional)	173
6.1.6 Graph Setup (optional)	174
6.1.7 System	174
6.2 MARK-RELATED	175
6.2.1 Mark Parameter	175
6.2.2 Frame/Fill	176
6.2.3 Delay	176
6.2.4 Array Copy	181
6.2.5 Motion (optional)	182
6.3 OBJECT-RELATED	183
6.3.1 Curve	183
6.3.2 Arc	184
6.3.3 Circle	184
6.3.4 Rectangle	185
6.3.5 1D Barcode	185
6.3.6 2D Barcode	186
6.3.7 Image	187
6.3.8 Text	188
6.3.9 Arc Text	189
6.3.10 Baseline	190
6.4 LAYER-RELATED	191
6.4.1 Layer	191
6.4.2 Input	192
6.4.3 Output	192
6.4.4 XY Table (optional)	193
6.4.5 Rotary (optional)	194
CHAPTER 7 POPUP MENU	195
7.1 GENERAL OBJECT	195
7.2 CURVE	196
7.2.1 Add Vertex	196

MarkingMate

7.2.2 Delete Vertex	197
7.2.3 Curve to Line	197
7.2.4 Line to Curve	197
7.2.5 Arc to Curve	197
7.2.6 Cusp	198
7.2.7 Smooth	198
7.2.8 Symmetrical	198
7.3 SHOW MARK ORDER OF A GENERAL OBJECT	199
7.4 SHOW MARK ORDER OF A CURVE	199
CHAPTER 8 HOT KEY	201
APPENDIX A: DRIVER MANAGER	203
APPENDIX B: MAKE_FNT	204
APPENDIX C: SHX TO FON	211
APPENDIX D: CONFIG.INI	212
APPENDIX E: MM.INI	215
APPENDIX F: AUTO TEXT – SERIAL NO. ADVANCE	216
APPENDIX G: MARK ON FLY	217
APPENDIX H: HOW TO CONTROL ALIGN LIGHT WITH MC-1	219

Chapter 1 System Installation

Welcome to the world of MarkingMate!

This chapter will tell you how to install the MarkingMate system, the hardware protect key, and how to work with MarkingMate and its related equipment.

1.1 Installation Notice

Please make sure your computer meets the following requirements before installing MarkingMate :

- Installing Windows 98/2000/XP operating system.
 - Hardware equipment compatible with Windows 98/2000/XP Operating System.
 - Monitor resolution is 1024*768
 - Plug in PCNCIO card or PCMark card, or MC-1 laser controller.
- ★ The PCNCIO card can only be used in Windows 98 system.
- ★ Before installation, remember to remove the old version of MarkingMate first if you have.

Supporting List				
Name	bus	Supports(Windows)		
		98	2000	XP
PCNCIO	ISA	√		
PCMARK	PCI		√	√
MC-1	USB	√	√	√

MarkingMate

1.2 MarkingMate Installation

MarkingMate offers a very user-friendly installation interface. It will copy all system related files to the directory you assigned to and prompt you with the necessary information step by step.

How to enter the MarkingMate installation:

Click [Start-Programs-Accessories-File Management] to execute the [Setup .exe] program in CD-ROM.

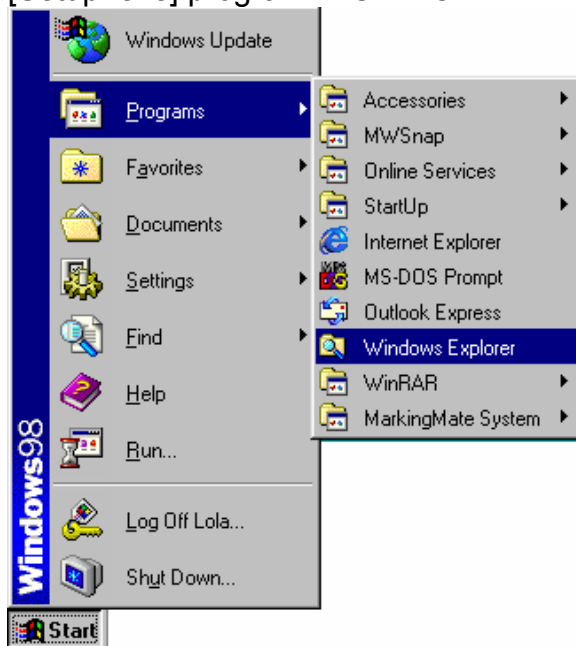

Click [Start-Run] to execute the [Setup.exe] program in CD-ROM.

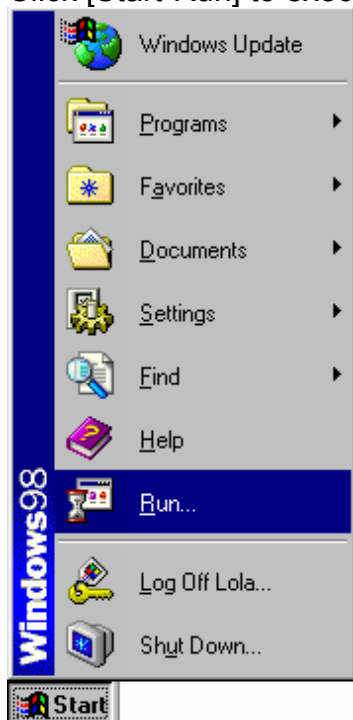

MarkingMate

When you get into the MarkingMate installation, the following frame appears:

Select Destination Directory

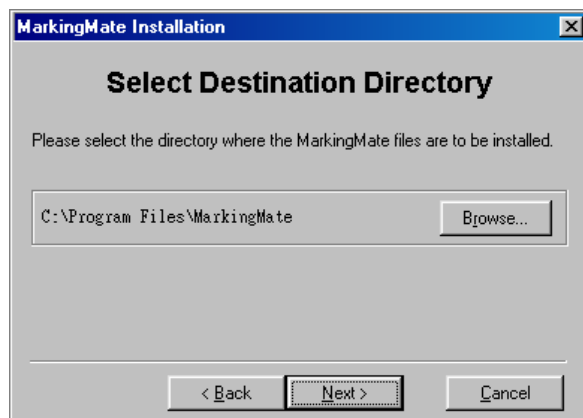

Ready to Install

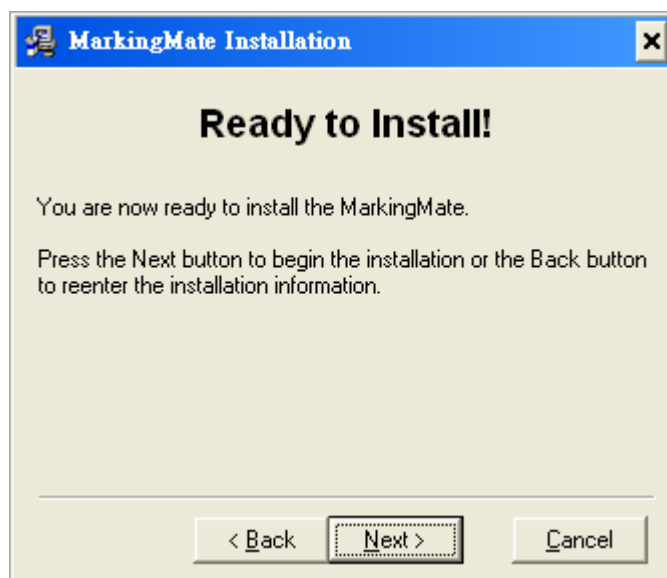

Select Upgrade or New Installation

MarkingMate

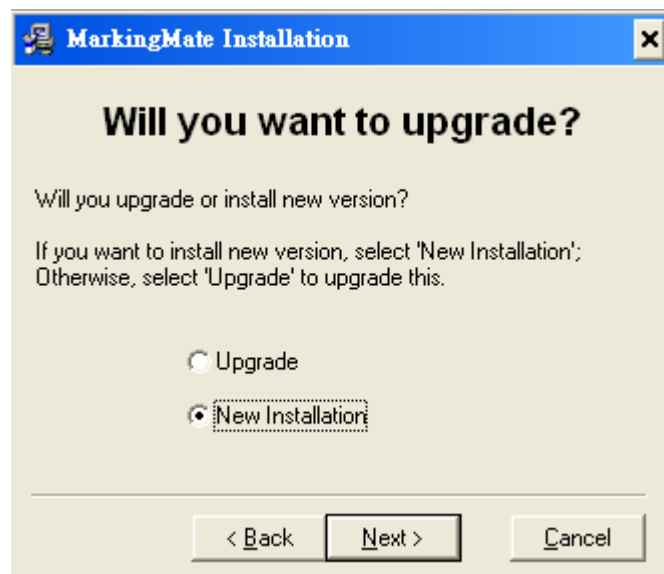

Select Laser Driver

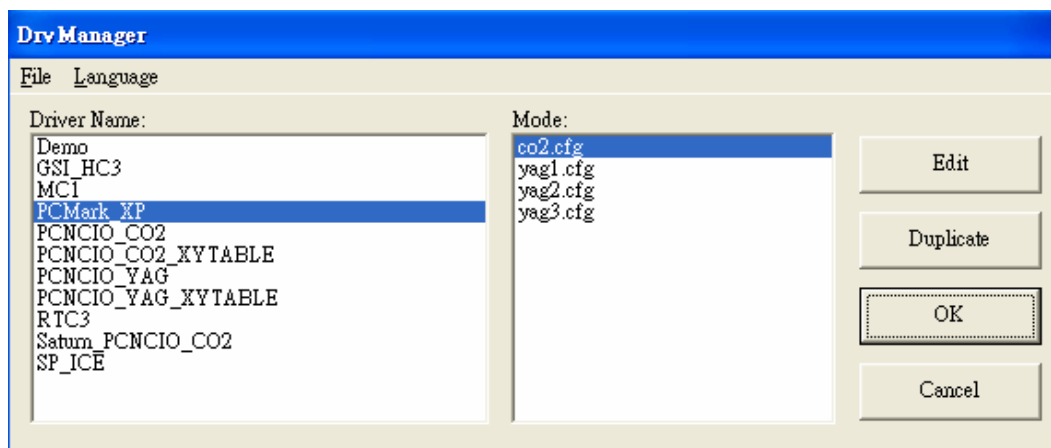

Installation Completed



MarkingMate

1.3 Hardware Protect Key Installation



The [Hardware protect key], provided together with [User's manual] and CD-ROM, is a small white box with male-to-female connector. If the [Hardware protect key] does not connect to computer correctly, the MarkingMate system will not be able to work normally.

How does the [Hardware protect key] work

Please plug the [Hardware protect key] into the "parallel port" (for printer) on the PC. It will work normally.

Except MarkingMate system, the [Hardware protect key] will not effect any other software or peripheral equipment connected to the "parallel port".

Notice

Every package contains one [hardware protect key] only, if it is lost or damaged, users can only get another one by purchasing another MarkingMate system. Therefore, users should take good care of the key.

If your [hardware protect key] was unable to work normally, please contact with the distributors to exchange a new one.

MarkingMate

Chapter 2 Quick Guide to Newcomers

MarkingMate allows users to draw pictures and import the other format files such as PLT, DXF, and BMP files which are generally created from the common use software like AutoCAD, CorelDRAW, Photoshop, and etc.

The import graphics will be maintained their shapes and scales so there is no need for any modifications that MarkingMate can use those graphics directly. Its operation is as below:

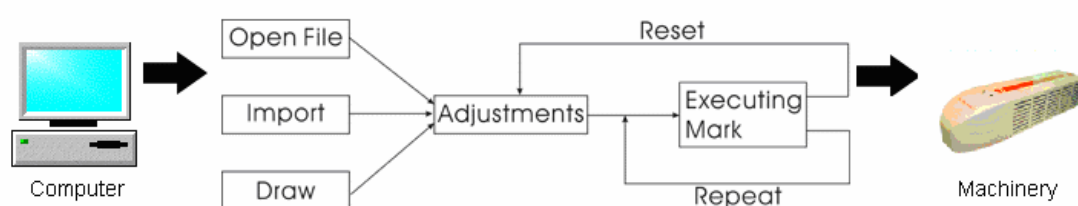

2.1 Start Program

There are two ways to start the program.

Click [Start - Program] from the left-bottom of the window and select MarkingMate to start the program.

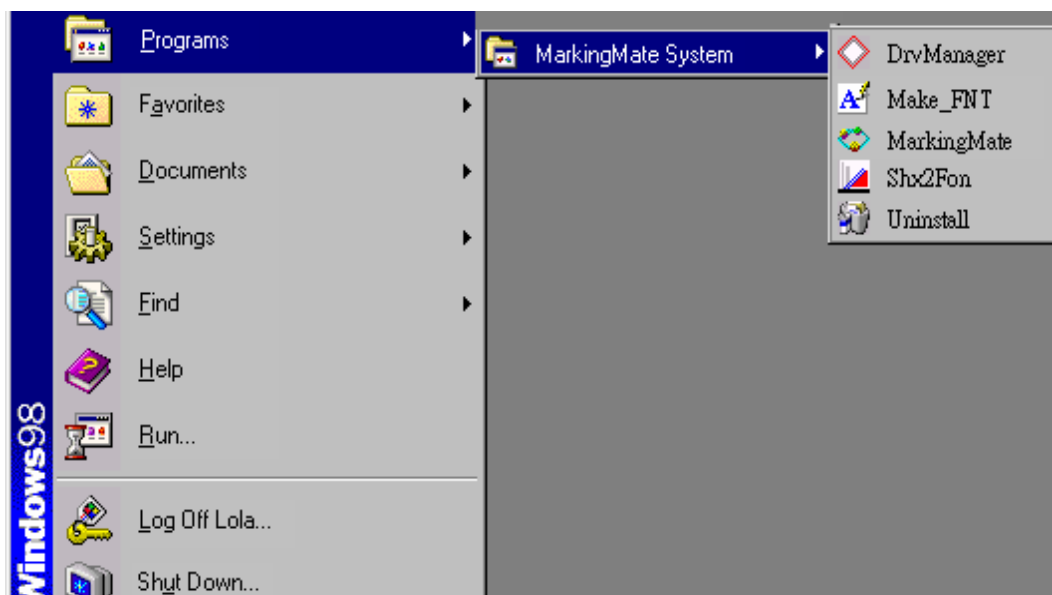

A shortcut icon of MarkingMate will be added in the desktop after installing the program, click this shortcut will be able to start the program.

MarkingMate

2.1.1 User Interface

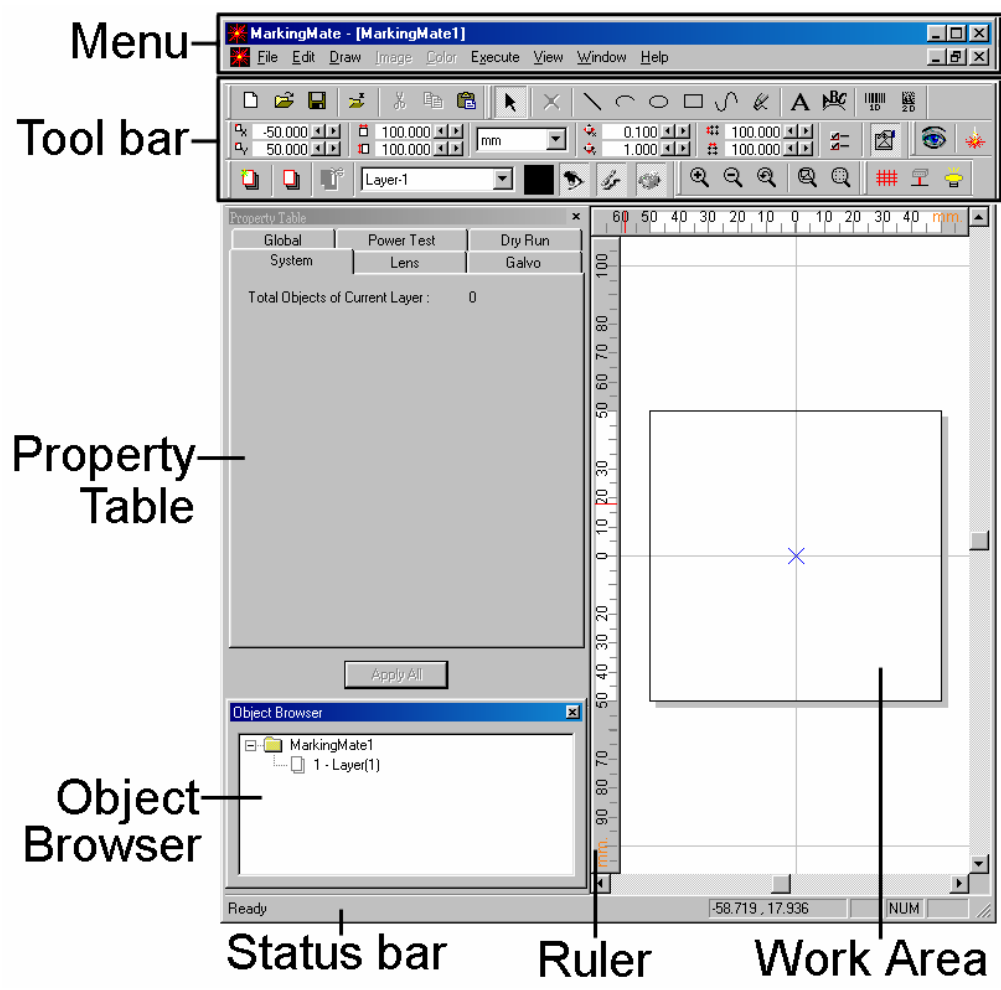

The user interface of MarkingMate are listed as below:	
Menu Bar	Menu Bar contains main function of this program, click each function will drop a list of related items.
Toolbar	The most common use function will be listed in the toolbar. Click and drag the toolbar can move it to any place you want. If you click and drag the toolbar to Work Area, it will become fluctuant; and if move it to the Window frame, it will become a part of the Window frame.
Property Table	Display the properties and related settings of the selected object.
Object Browser	Display all objects in the Work Area.
Ruler	Help users to realize the dimension of the object.
Status Bar	Display the function comment and coordinates of mouse.
Work Area	The area allows users to draw and edit.

MarkingMate

2.2 Read Files

In MarkingMate program, you must create a file before marking. There are three ways of creating files: open, import, and draw.

2.2.1 Open

Click "File - Open" from Menu Bar or click the  button from the Standard Toolbar, a dialogue box will appear.

Select the file you want from the directory and click "Open" button.

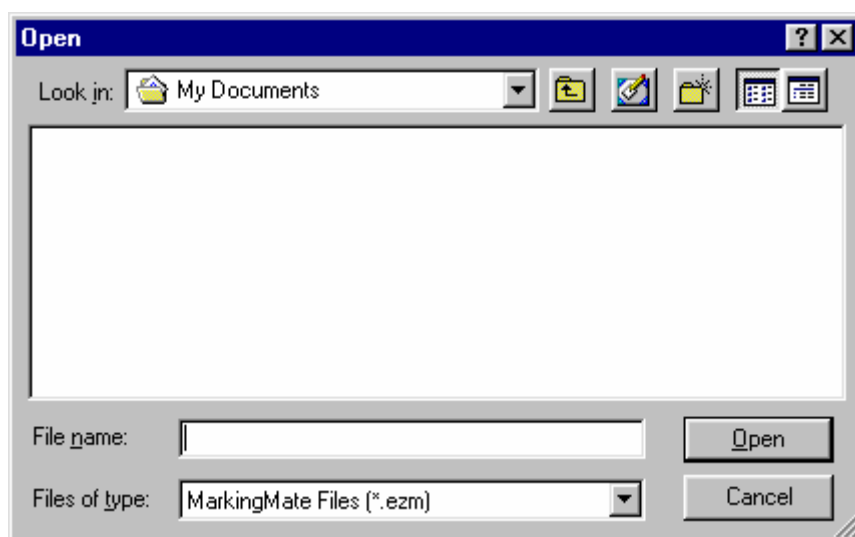

Edit the file to meet your needs.

2.2.2 Import

Click "File - Import" from Menu Bar, a dialogue box will appear. Select the file you want to import from its directory and click "Import" button. You can also click the  button from the Standard Toolbar.

MarkingMate

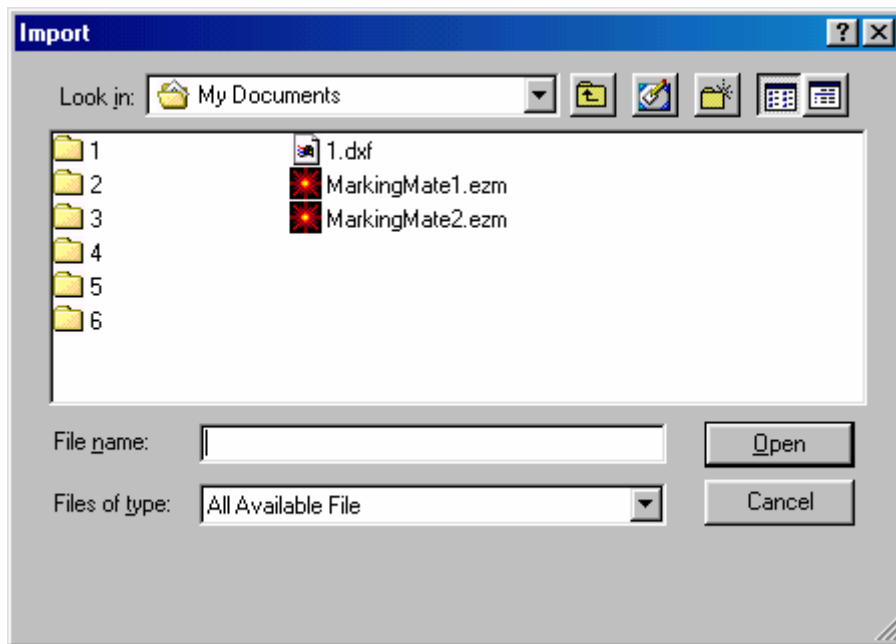

Select the file you want to import, and then click the “Open” button. The selected picture will be displayed on the left-down corner of the work area.



When import a graphic object (like a DXF file), users can use “Edit – Break” function to break the selected object into several objects.

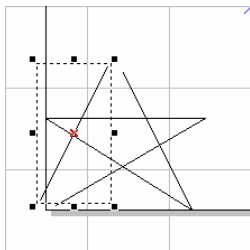

MarkingMate

2.2.3 Draw

Click "File - Open" from Menu Bar, a new Work Area will be displayed. Besides, you can click the  button from the Standard Toolbar.

Click "Draw - Rectangle" (or other draw tools) from Menu Bar, draw any figures in the Work Area (as the right figure), or click the buttons from Toolbar.

After finishing drawing, still can edit the figures. For example: select all objects, click "Edit - Combine" from the Menu Bar.

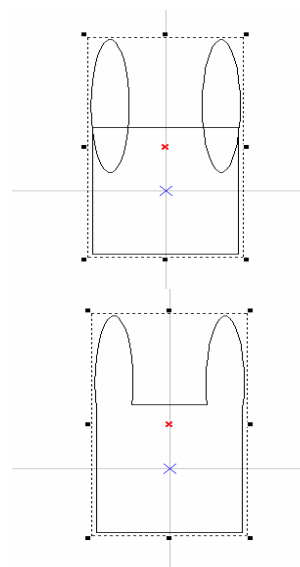

MarkingMate

2.3 Parameters Settings

2.3.1 Position Adjustments

If the object position, scale, and direction do not meet your requirements, you can use the mouse or toolbar to do the adjustment, Properties Bar, or Dimension Bar. The frequently use functions are as following:

Place center:

Click the  button on the Property Bar, the picture will be put in the center of the work area.

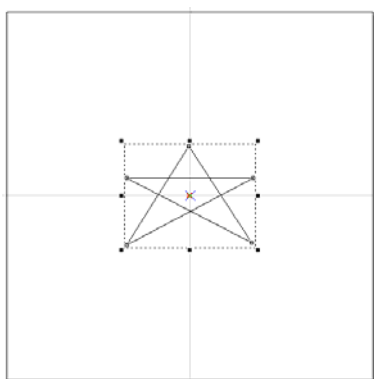



Align

Click “Edit - Align”, a dialogue box will be displayed. Users can push the  button on the Property Bar also. In the align dialogue box, users have three ways of “align to” (Last Select Object, Paper Edge, and Paper Center) and six directions (Top/Center/Bottom, and Left/Middle/Right) to choose.

Examples:

Create several objects and select all objects (as figure 1 below). Click “Edit – Align” from Menu Bar, press

Left  button and Top  button will see that all objects were aligned to the last object (as figure 2 below).



MarkingMate

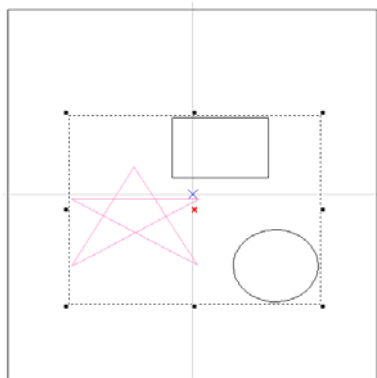



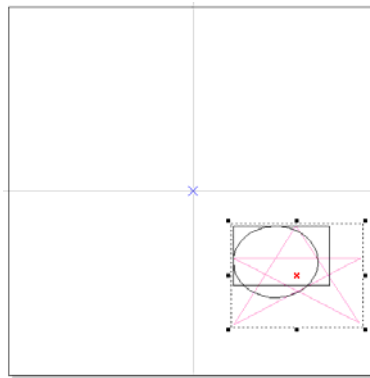

(Figure 1)





(Figure 2)

Dimensional Bar

Dimensional Bar contains four main functions: Position , Rotate , Aslope , and Scale .

Position :

Click the  button on the Dimensional Bar and then input the values of horizon and vertical position directly.

Examples: Select an object, click the  button, set relative position to right, and press “Apply for Clone” button, will see the result as below:

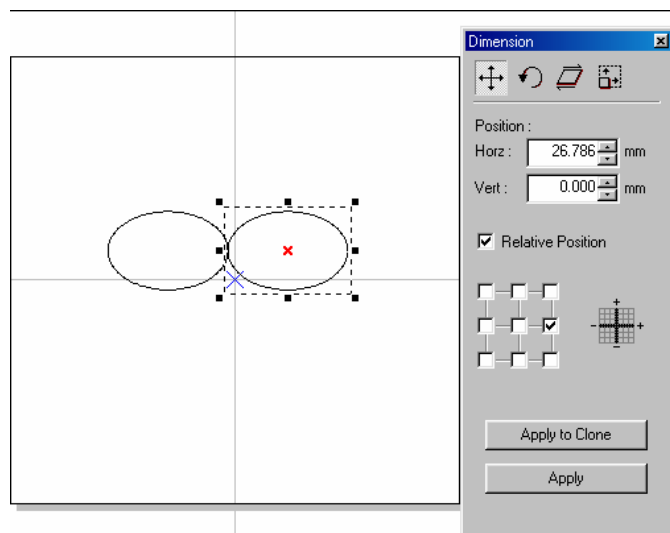

Rotate :

Click the  button on the Dimensional Bar and then input the rotate angles and rotate center position.

Examples: Select an object, click the  button, set Angle to 45 degree, center position as “top-left”, and press “Apply for Clone” button, will see the result as below.

MarkingMate

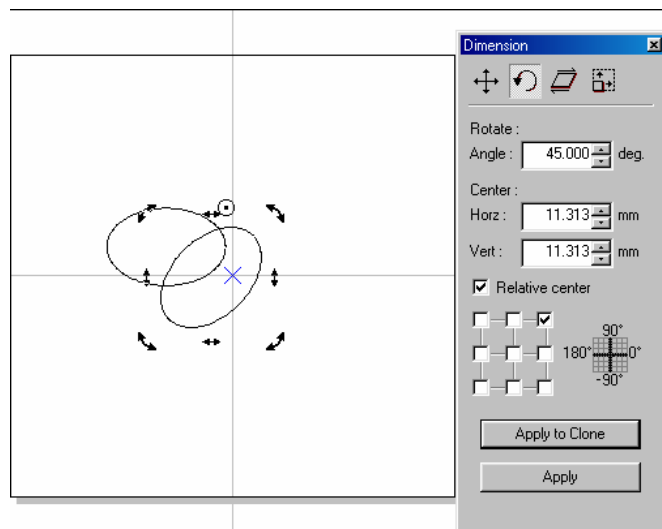

Aslope :

Click the  button on the Dimensional Bar and then input the aslope angle you want.

Examples: Select an object, click the  button, set aslope angle to 45 degree, set anchor point as “top-left”, and press “Apply to Clone”, will see the result as below:

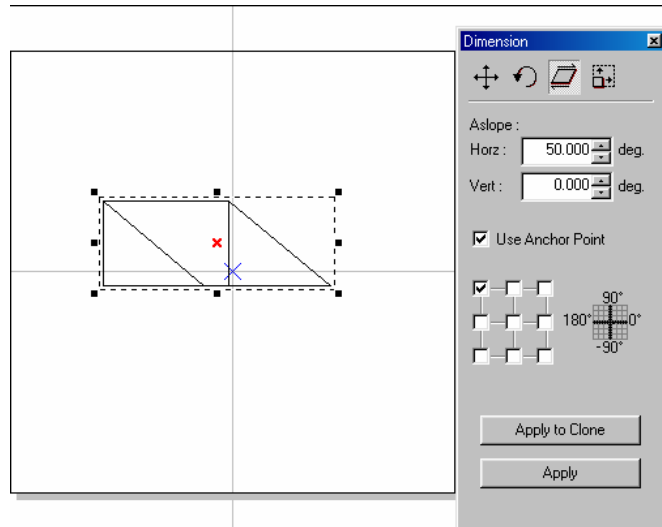

Scale :

Click the  button on the Dimensional Bar and then input the dimension you want.

Examples: Select an object, click the  button, set scale of horizon as 50mm, marked the “Same Ratio” checkbox, set relative position as “bottom-left”, and press “Apply for Clone” button, the result will be as below:

MarkingMate

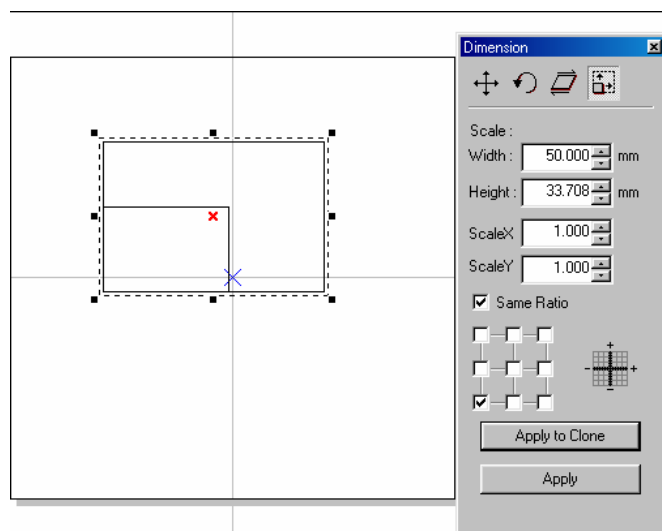

2.3.2 Marking Parameters

We recommend users to do test marking first before setting marking parameters.

Test Marking: Create a rectangle, place the object in the center of the Work Area, execute Mark function, and then do the marking parameter setting.

The Property Table (no object being selected):

Working Area : The software system uses voltage signals to control GALVO motor, it is unable to know how big the working area is unless user input the correct value. If the work area is 100mm, user should enter 100mm over here. If it is mistaken to be 50mm, the finished goods will be doubly enlarged; on the other hand, if it is mistaken to be 200mm, the finished goods will become half size.

Offset – Normally set X=0 and Y=0 will be fine. However, if system output 0V to X, Y GALVO motor and the laser did not shoot from the center of the f-theta lens, we strongly recommend user to regulate your hardware first, only if you can not succeed from regulating hardware will you try to adjust offset from here. If the mark position is right shift 5mm, you can enter -5mm in the X column. So are the others.

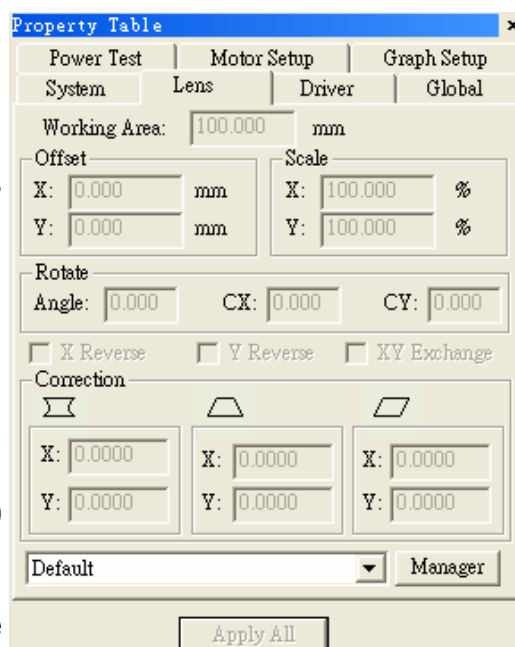

MarkingMate

Scale – Even though every adjustment is correct, still many reasons to cause abnormal scale of the marking goods. Some special item needs to be marked under unfocused situation to create special effects will also result in scale enlarged or shrink. If the scale is too small, please enter a number bigger than 100 (because unit is percentage); on the contrary please enter a value smaller than 100.

Rotate – the mechanism problem will also cause rotate. If so, please fix it to avoid this problem. If hardware is OK, user can rotate an angle of the image to resolve the limitation problem of the Work Area

X reverse / Y reverse / XY exchange

It is possible that user has to adjust the coordinates of the Work Area for his local condition. Our system provides X reverse, Y reverse, and XY exchange for users to choose or combine as their requirements.

Correction

Except barrel distortion, every distortion is result from hardware. Therefore, DO NOT expect on software correction before hardware adjustment, because software correction is based on hardware is correct. If hardware is not property settled, even software can control well, the performance will not be good anyway.

Barrel Correction

A normal f-Theta Lens system will result in barrel distortion because its naturals. The system initial value here is (0.000), if the figure become protuberant in X-axis, the X value will need to be increased like 0.002; while if now it become indentation, the X value will have to be reduced to as 0.0014. Keep adjusting the value until it is acceptable.

Input a square, the output become as below:

Lens Name

The name of the lens parameters. If you want to add other lens parameters, just press the “Manager” button, the Lens Setup page will be displayed as below:

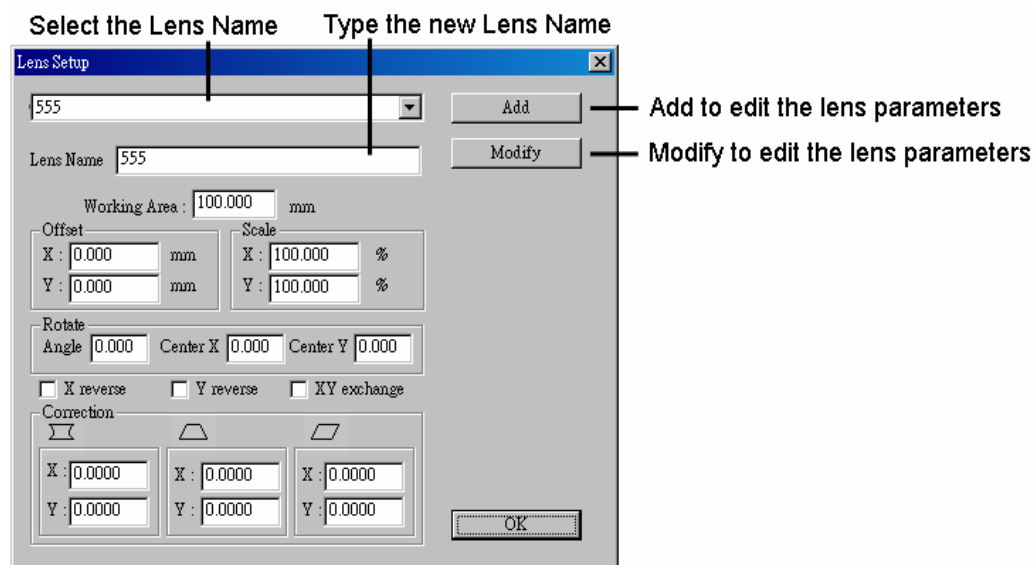

MarkingMate

Global

Marking Maximum: Set up the desired total working times.

This function allows you to avoid the unwilling excess working pieces.

Marking Amount: It enables you to take down how many work pieces you have already done.

Trigger Max: Specify the counts of marking for trigger. Show the message for trigger.

Show MSG: If checked, the system will show message while the marking amount reaching the Trigger Max value.

Comment: Input a summary of the file.

Mark On Fly: It enables you to mark while the working pieces are moving. You can choose to use this function on X or Y Axis.

X/Y Encoder (checked):

Factor: the value of conveyer moving per encoder count.

Delay: delay a giving count pulse then start marking.

The screenshot shows the 'Property Table' dialog box with the 'Global' tab selected. The 'Marking Max' is set to 0, 'Marking Amount' is 0, and 'Trigger Max' is 0. The 'Show MSG' checkbox is unchecked. The 'Mark On Fly' section has 'X Axis' and 'X Encoder' unchecked, and 'Y Axis' and 'Y Encoder' checked. The 'Speed' for both X and Y axes is 0.00000 mm/sec, and the 'Delay' is 0 us. There are 'Set Default', 'Apply', and 'Apply All' buttons.

X/Y Encoder (not checked):

Speed: the speed of conveyer.

Delay: delay a giving count pulse then start marking.

The Property Table (with some objects being selected):

Mark Parameter:

This menu allows you to edit the assigned speed, power, and frequency output of the laser machine. Each pass can be assigned with different speed, power, and frequency settings. In addition, you can also load the value from the Object Parameter Table.

Pass Mode: Select from the list from "1 Pass" to "5 Passes".

Speed/Power/Frequency: Input the related values.

Times: If set the value to be "5", the mark time will be 5 times.

MarkingMate

Property Table

Delay	Array Copy	Motion
Text	Mark Parameter	Frame/Fill

3 Passes Pass--2

Frame Fill

Speed: 800.0 mm/sec Times : 1

Power: 20.0 % Spot Delay : 0.100 ms

Freq: 20.00 kHz

Wobble

Set Default Load... Apply

Apply All

Mark Parameter List

Parameter Path: C:\Program Files\MarkingMate\MarkParam

Item Name	Item-0				
Pass	3-1	3-2	3-3		
Speed	800.0	800.0	800.0		
Power	20.0	20.0	20.0		
Freq	20.00	20.00	20.00		
Times	1	1	1		
Spot Delay	0.100	0.100	0.100		
Pulse width	50	50	50		
Start Point Delay	0.000	-----	-----		
Midpoint Delay	0.100	-----	-----		
End Point Delay	0.300	-----	-----		
Jump Speed	3000.0	-----	-----		
Jump Delay	0.200	-----	-----		

New Item Delete Item Save Modify Exit with Save and

Advanced Operation

Copy to a New Item Restore Modify

MarkingMate

Delay

This function is used to overcome the problem of motor inertia.

Start Point Delay:

The time differences between system start and laser start at the beginning.

Too much delay results in faded, while too little delay results in hot spots.

Poly Delay:

The time needed when system makes a turn. Too much delay will creates excess marking, while too little delay will appears an arc in the corner.

End Point Delay:

The time differences between system stop and laser stop. Too much delay will make hot spots in the end of line, while too little delay will result in incomplete lines.

The screenshot shows a 'Property Table' dialog box with a tabbed interface. The 'Delay' tab is selected. The 'Mark Parameter' section is active, showing three delay parameters: Start Point Delay (0.000 ms), Poly Delay (0.100 ms), and End Point Delay (0.300 ms). The 'Jump Param' section shows Speed (3000.0 mm/sec) and Delay (0.200 ms). There are 'Set Default' and 'Apply' buttons in the 'Mark Parameter' section, and an 'Apply All' button at the bottom.

Rectangle	Mark Parameter
Frame/Fill	Delay Array Copy

Delay Param

Start Point Delay:	0.000	ms
Poly Delay:	0.100	ms
End Point Delay:	0.300	ms

Jump Param

Speed:	3000.0	mm/sec
Delay:	0.200	ms

Set Default Apply

Apply All

MarkingMate

2.4 Execute Mark

Click “Execute – Marking” from the Menu Bar or press the  button from toolbar will see a dialogue box as below:

Click the “Exec” button in the dialogue box to execute marking.

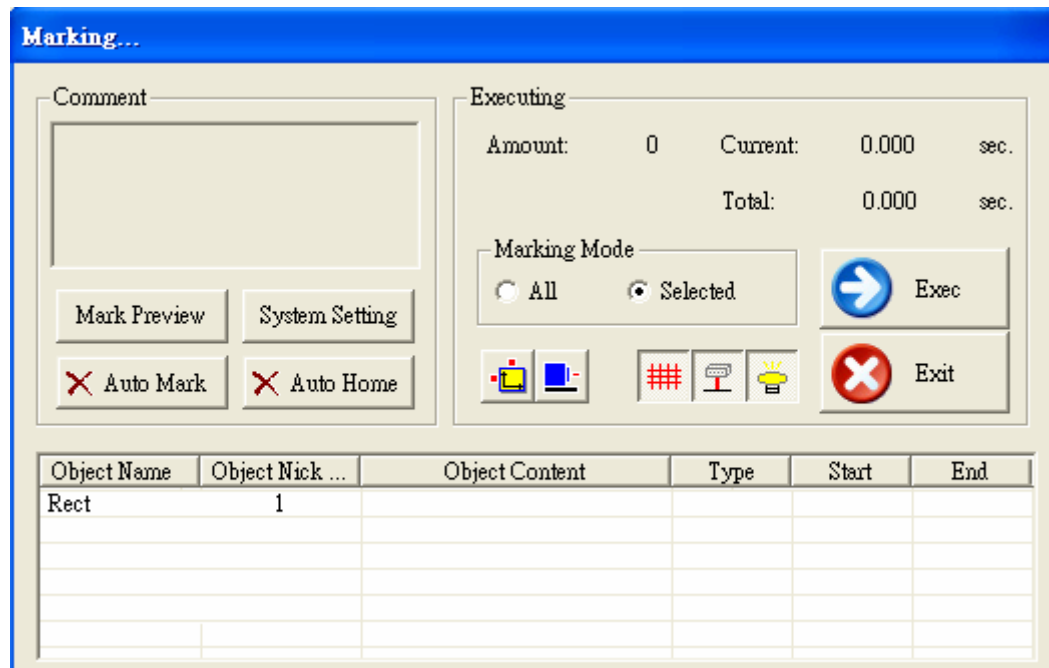

MarkingMate

2.5 Operation Examples

2.5.1 Import DXF File

Step 1: Click “File - Import” or click the  button from the Standard Bar will enter the dialogue box as below.

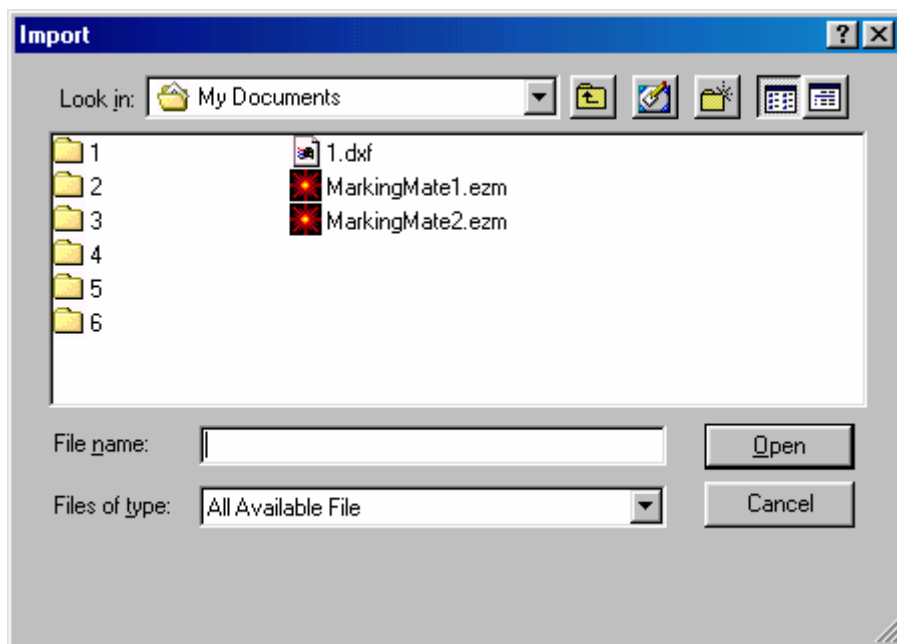

Step 2: Select the DXF file you want, and then click the “Open” button.

Step 3: The selected DXF file will appear in the left-down corner of the working area.

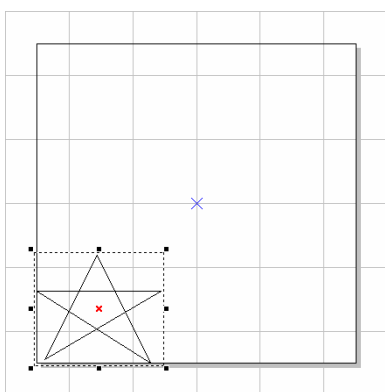

Step 4: If it is a graphic object, click “Edit - Break” to break it into several objects.

MarkingMate

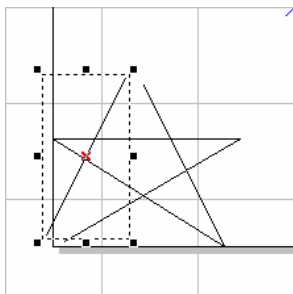

Step 5: Edit the object's properties from the Property Table:

(1) Frame/Fill – Adjust the color of the border and interior shading of the selected object.

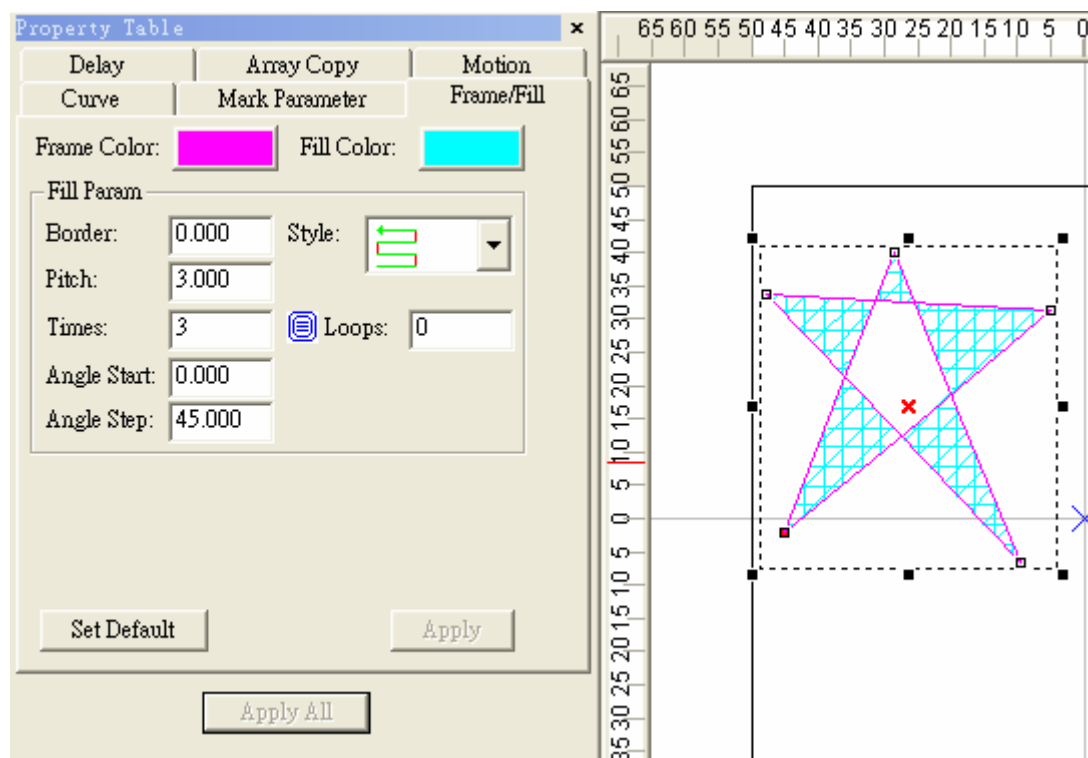

(2) Click the  button on the Property Bar to move the object to the center of working area. Next, click the  button to set the rotate angle to 60 degree and the relative position to the “top-right”.

(3) Hit the “Apply to Clone” button as the following:

MarkingMate

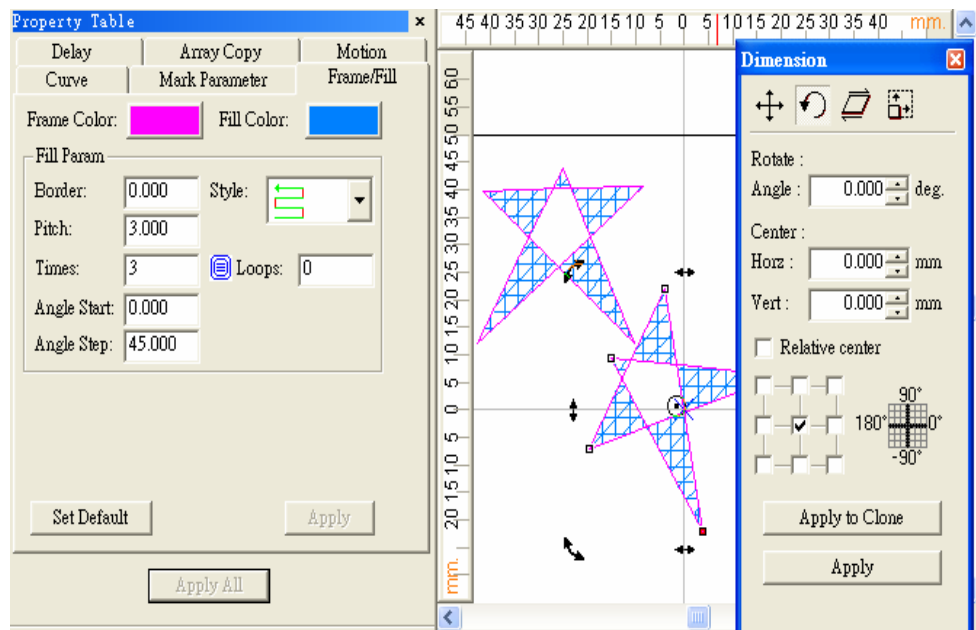

(4) Marking Parameters Settings

Set the mark cycle to 3 Passes; and each pass reload different values from Object Parameter Table.

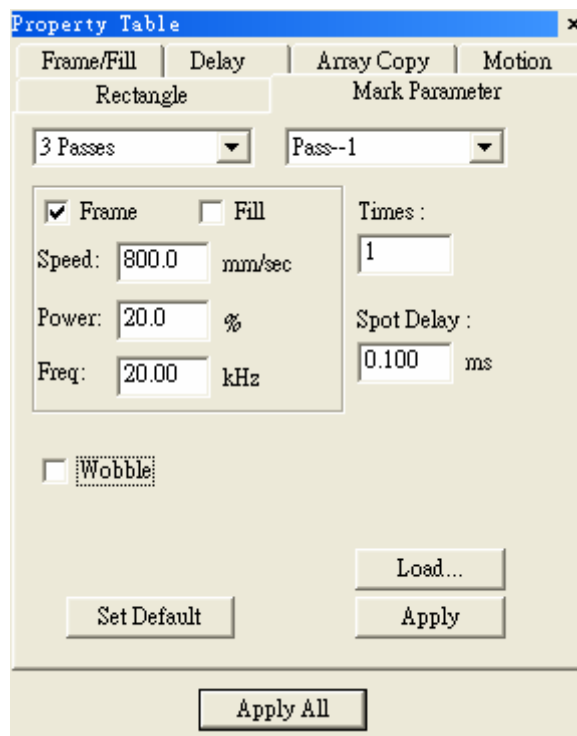

MarkingMate

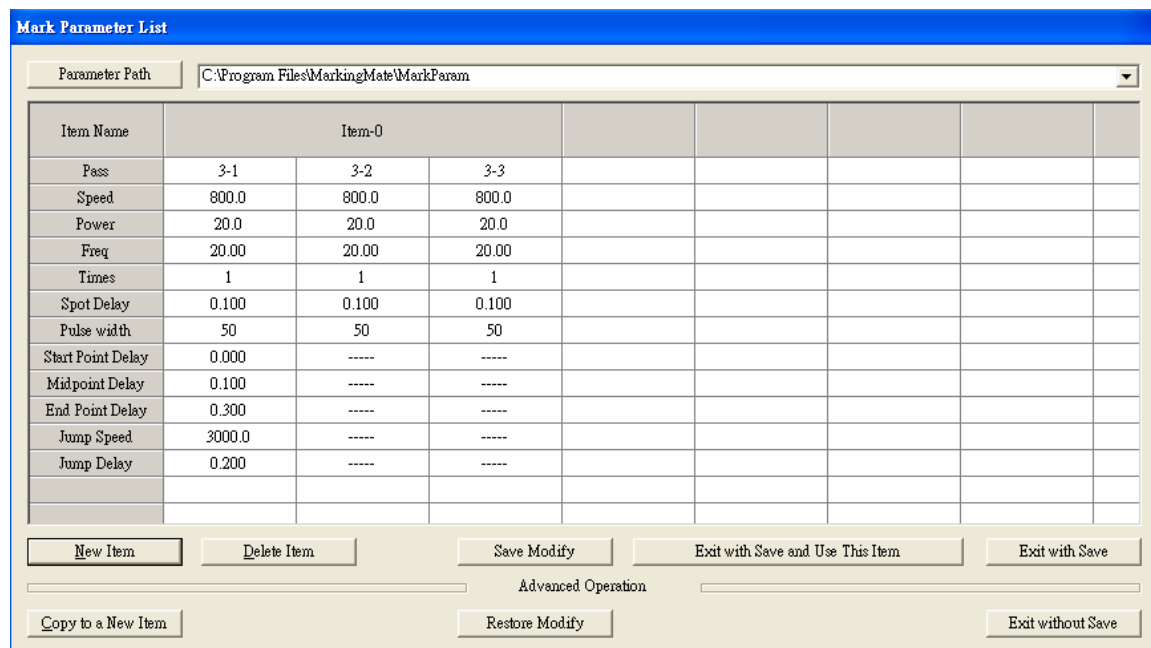

(5) Cancel the selection, go to the Global page of the Property Table, and set the Marking Maximum to 10.

(6) Click “Execute – Marking” will display the dialogue box, and then click “Exec” button in the box, the system will display its current marking status.

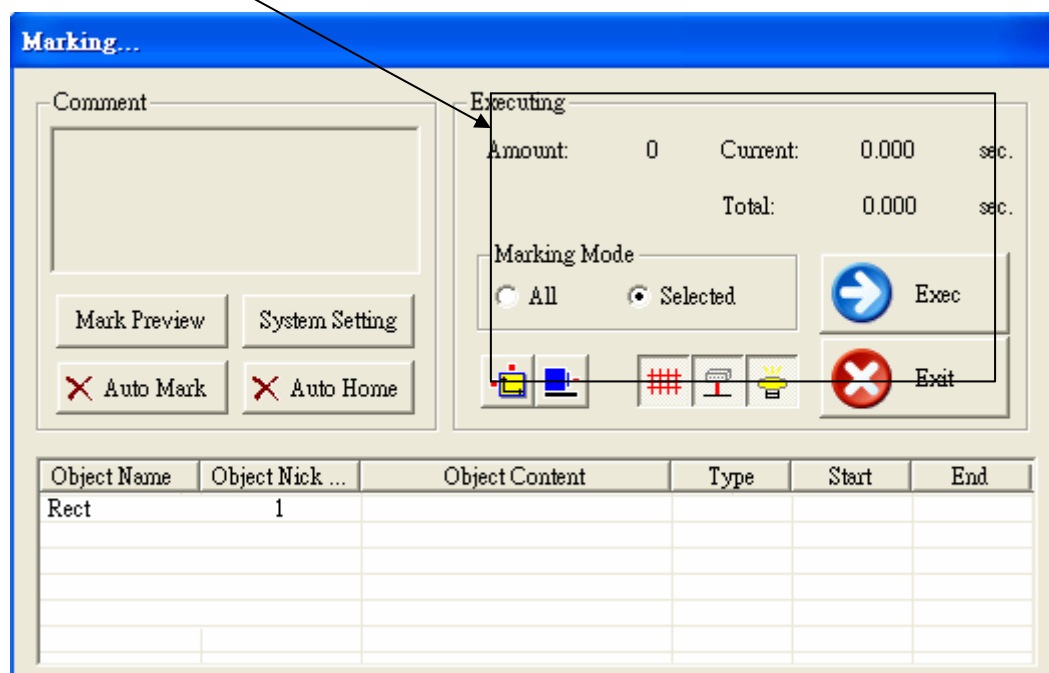

MarkingMate

2.5.2 Auto Text

Step 1: Click “Draw – Text” from Menu Bar, or click the **A** button from toolbar.

Step 2: Move your mouse to the Work Area and click, a text input box will be displayed; typing the characters you want and then click the right button of the mouse to leave.

Step 3: Go to the Text page in Property Table (as below), check the box of “Auto Text”, the “Auto Text Manager” will appear as below.

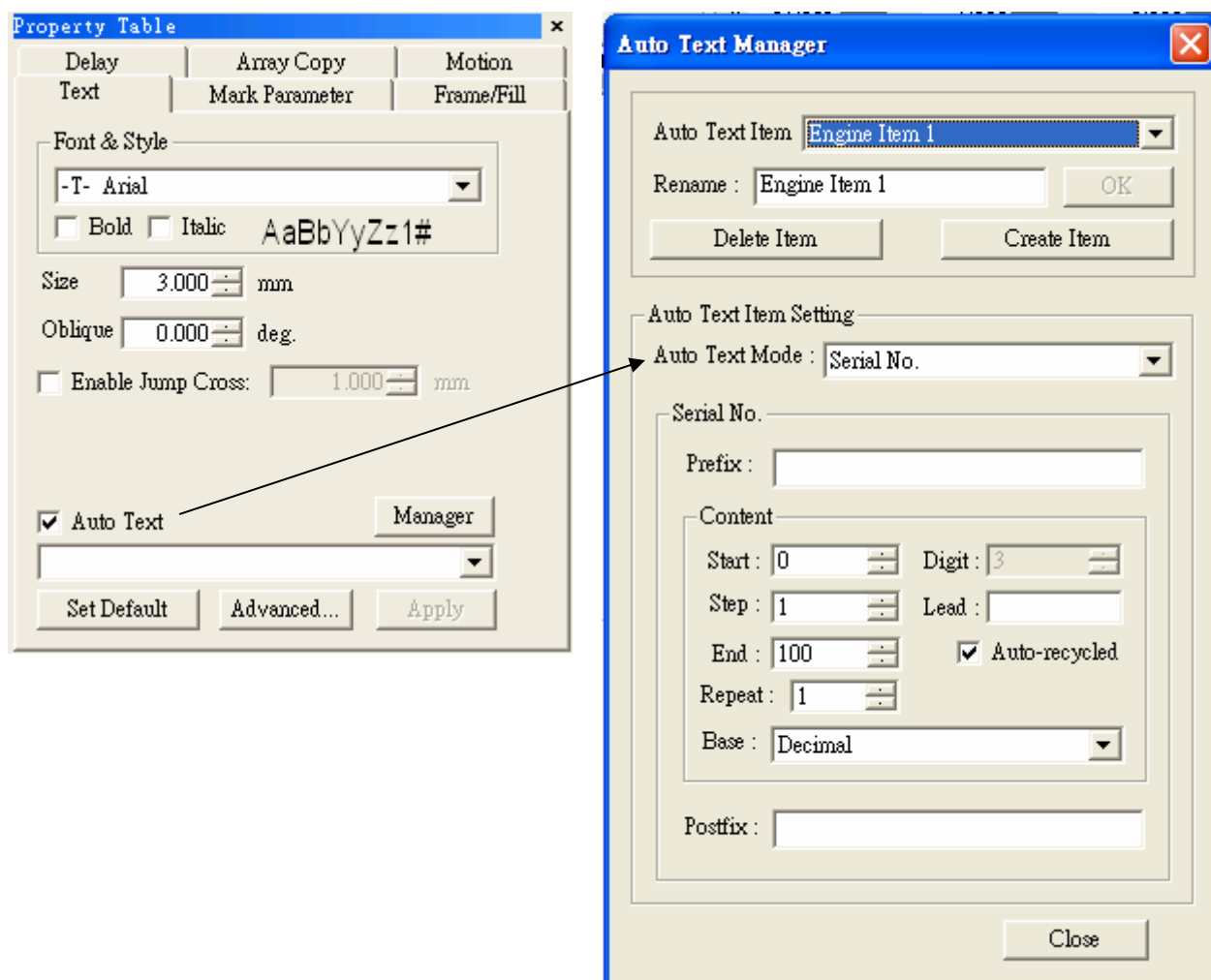

Step 4: There are 7 different modes of Auto Text. Now we take the “Serial No.” as examples. The serial no. content start from 0, step 1, and end at 100 (users can define by themselves). Click “Close” and “Apply” buttons, the text will be changed as setting as figure below, the value has become the initial value of the Auto Text (see the right figure below). If you follow the above setting to create another Auto Text, the value will be next by order. (More detail description of Auto Text please refers to section 2.5.2.1.)

MarkingMate

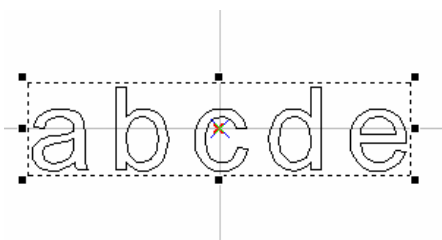

The original text

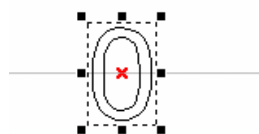

After applying Auto Text – Serial No.

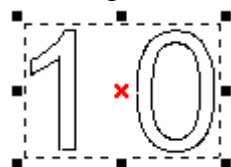

10 based on decimal

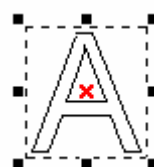

10 based on hexadecimal

Step 5: Go to the Property Table of the object

(1) Frame/Fill – Adjust the color of the border and interior shading of a selected object.

(2) Click  button on the Tool Bar to move the object to the center. Click the right button of the mouse and click the “Array Copy” function, a setting dialogue box will be displayed.

(3) Select Array Copy Mode: By Circle, set circle radius as 10mm, object count 8, and check the checkbox of “Auto Angle”, “Rotate Obj”, and “CCW Copy”, and click “Apply” button, then the content will be changed as below:

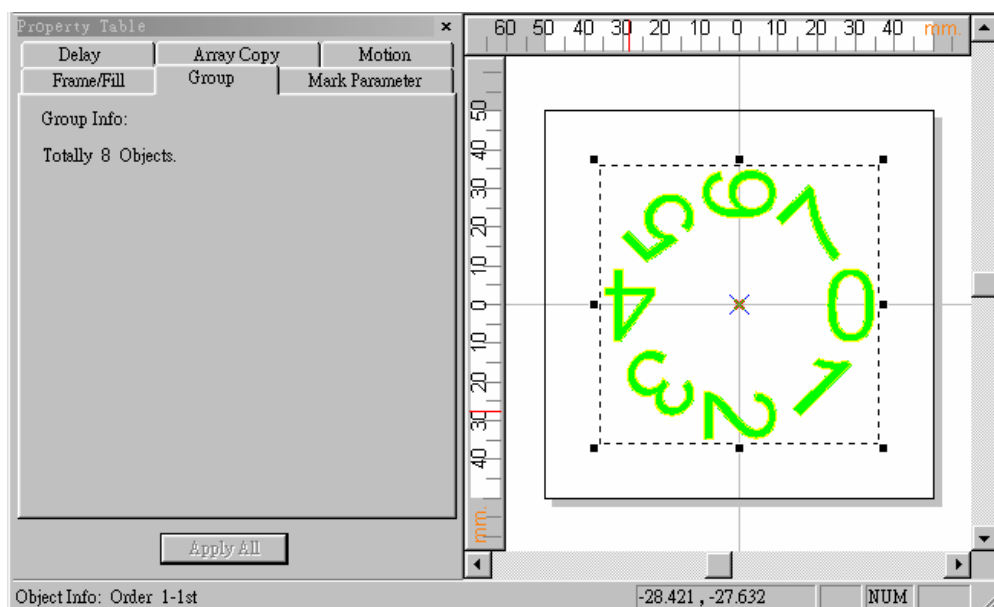

(4) Marking Parameter Setting – Set the mark cycle to 2 Passes.

(5) Click “Execute – Marking” will appear the Execute dialogue box; and then click “Exec” button, the current status of each Auto Text will be displayed as

MarkingMate

below:

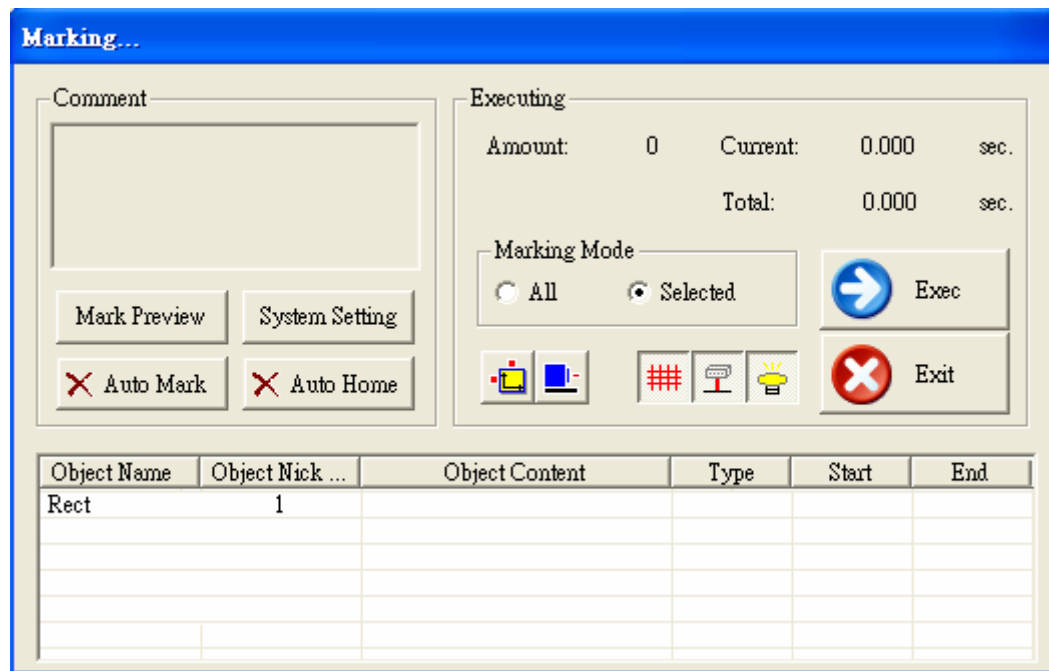

MarkingMate

2.5.2.1 Auto Text Setting

First create a text object and select it, go to the Text page in Property Table (as below), check the box of “Auto Text”, the “Auto Text Manager” will appear as below:

Auto Text Manager

The default Auto Text Item named “Engine Item 1”, you can change the name by entering a name in the “Rename” column and click “OK”. When you press the “Create Item” button will create second Auto Text Item, if you want to delete the item, just press the “Delete Item” button.

Auto Text Item Setting

There are seven different modes of Auto Text, includes: Serial No., File, Keyboard, Date, Comm Port, Serial No. Advance, and TCP/IP.

◆ Serial No.

This function will engrave fixed and increasing numbers onto the marked object. Numbers inserted as **Prefix** and **Postfix** will represent the constant numbers engraved at the beginning and end of the serial number.

Content

Start: the beginning number

Step: increment level of the increasing numbers.

End: the end number

Repeat: repeat time for each number

Digit: the total number of fixed number to be applied to the content portion. 0 means no limitation.

Lead: fill up characters
For example if 4 digits were selected, and leads 0 then 1 would be represented by 0001.

Recycle: will repeat automatically from the start number once the end number has been completed.

Base: default setting is Decimal system.

For example: if set the content as Start: 0, Step: 1, End: 100, Repeat: 1, Base: Decimal, Digit: 3, Lead: 0, and checked the “Recycle” checkbox and then execute marking, the result will be 000 001 002 003 004.....099 100 000 001 002....

The screenshot shows the 'Auto Text Manager' dialog box. It is divided into several sections. The top section is for managing items, with a dropdown for 'Auto Text Item' (currently 'Engine Item 1'), a 'Rename' text box (also 'Engine Item 1'), and 'Delete Item' and 'Create Item' buttons. Below this is the 'Auto Text Item Setting' section, where 'Auto Text Mode' is set to 'Serial No.'. The 'Serial No.' section includes a 'Prefix' text box. The 'Content' section contains several spinners: 'Start' (0), 'Digit' (3), 'Step' (1), 'Lead' (empty), 'End' (100), and 'Repeat' (1). There is also a 'Base' dropdown set to 'Decimal', a checked 'Recycle' checkbox, and a 'Special carry' button. At the bottom, there is a 'Postfix' text box and a 'Close' button.

MarkingMate

◆ File

Using File as an Auto Text Mode, you can build up a text format file in advance. You can insert a name list or address list, etc.

Select File: to designate the source of your information.

Start: choose the start row of the file.

Recycle: to repeat automatically from the start number once the end number has been completed.

For example: if the content of the file is as below:

abcd
efgh
ijkl
...

The mark result will be “abcd” at the first time, and “efgh” at the second time, and etc.

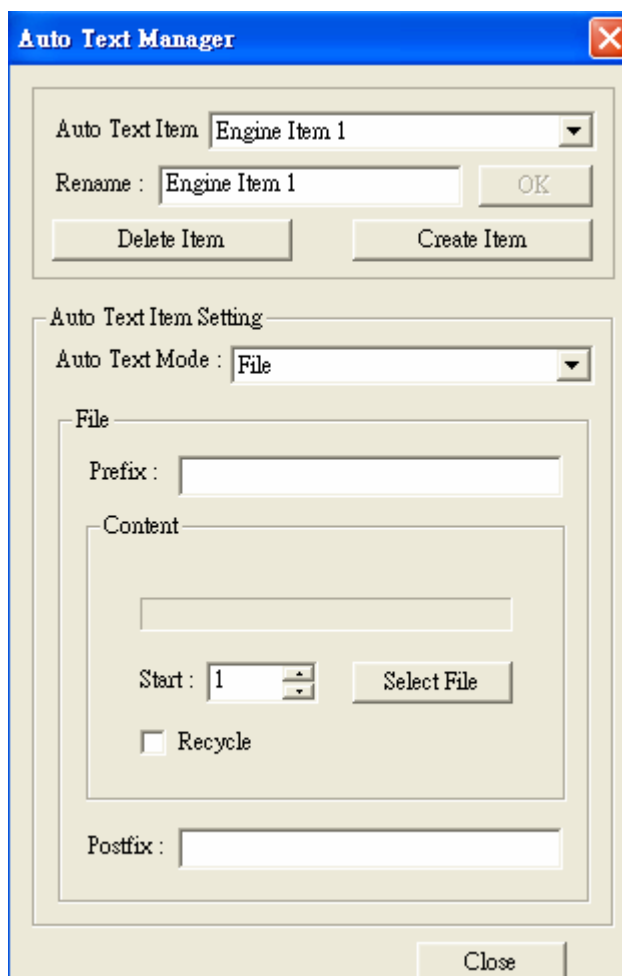

MarkingMate

◆ Keyboard

You can directly type in the text you want from the keyboard.

Prompt: the prompt of the dialogue box. For example: if you add “Input text from keyboard” as the prompt, the dialogue box will be as below:

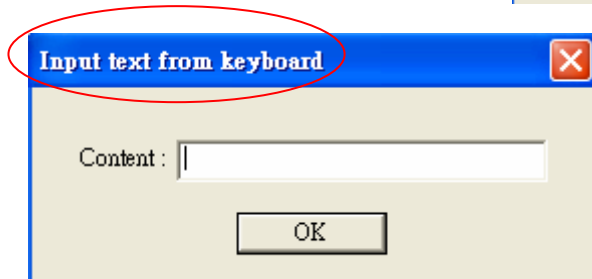
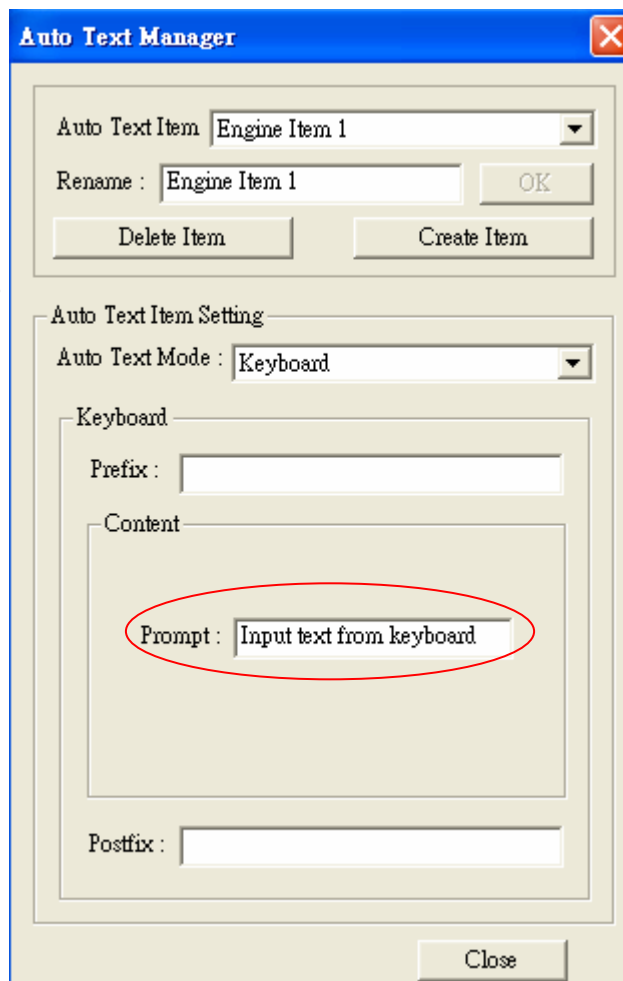

MarkingMate

◆ Date

In addition to prefix and postfix settings, this will allow you to insert various date formats into the content of the Auto Text number.

Format Command

%Y	Year
%M	Month(number)
%B	Month(English)
%b	Month(abbr.)
%?M	Month(assign)
%D	Day
%J	Solar Day
%H	Hour(24-hours)
%-H	Hour(12-hours)
%N	Minute
%A	AM or PM
%S	Second
%W	Week(English)
%w	Week(abbr.)
%U	Current Week Number

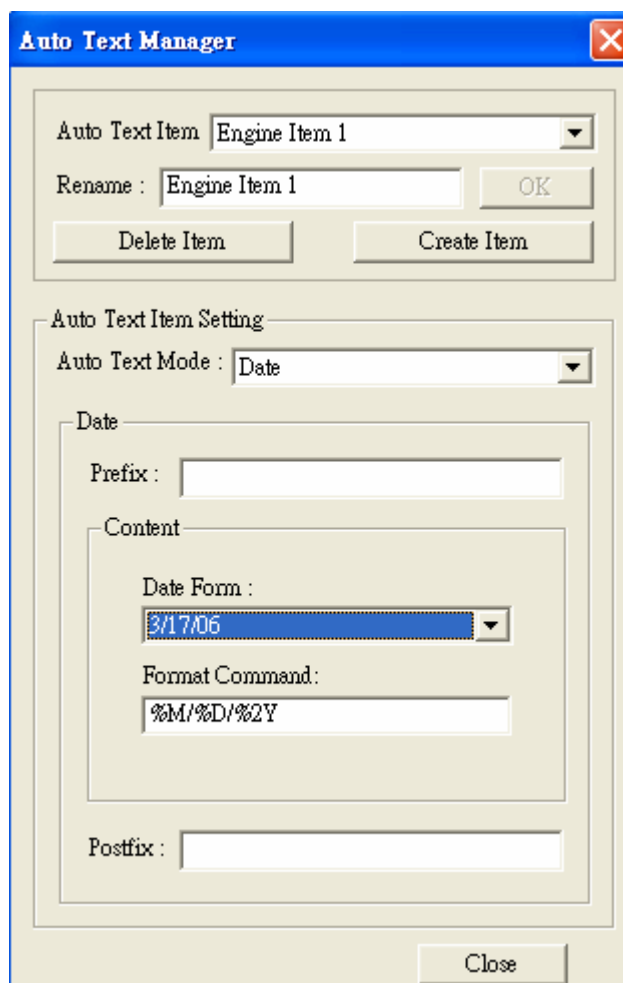

If your format command is “%?M”, the system will read the content from the file of “YOUR INSTALLED PATH\DATA\MON.TXT” , and fill it in the Auto Text.

For example, if the software was installed in C:\Program Files\MarkingMate, then the file will be in C:\Program Files\MarkingMate\DATA\MON.txt.

The first line in the file represents the content of January; while the second line represents the content of February, and so on. The content below the twelfth line will be neglected.

Each line can contain 18 characters at most (a Chinese word counts 2 characters). More than 18 characters in one line may cause unexpected errors.

If less than 12 lines in the file, the lack of content will be replaced by the string of “FMonth”.

MarkingMate

◆ Comm Port

Content

Data Start Cmd: when receiving the data in this field means the data next to this will be the right content for marking. If this field is empty, then the first receiving data will be considered as the content of auto text.

Data End Cmd: this is a necessary setting, when receiving this data means data sending completed. This field is not allowed empty, otherwise a warning message will be appeared for system could not tell when to close transmission.

Ack Cmd: when system receive “Data End Cmd” and “Check Sum” (if checked) and identify no mistakes occurred during transmission, can choose to send this signal to control end for representing the receiving is right. Its default value is \6.

NG Cmd: If the Check Sum value is not correct, the system will send this signal to control end to indicate there is an error. Its default value is \21.

Check Sum: this is for further verifying the data’s correctness. Its calculating method is to do the XOR calculation for the n-1-th and the n-th characters in a hexadecimal base, the last result will be the value of Check Sum. For example: the check sum value of data “2578” is “08”, its operation is as below:

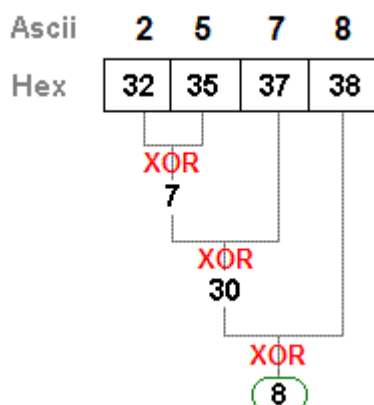

Confirm Data: If check this checkbox, then the data can be marked only after the user clicking the “OK” button in status dialogue box as below:

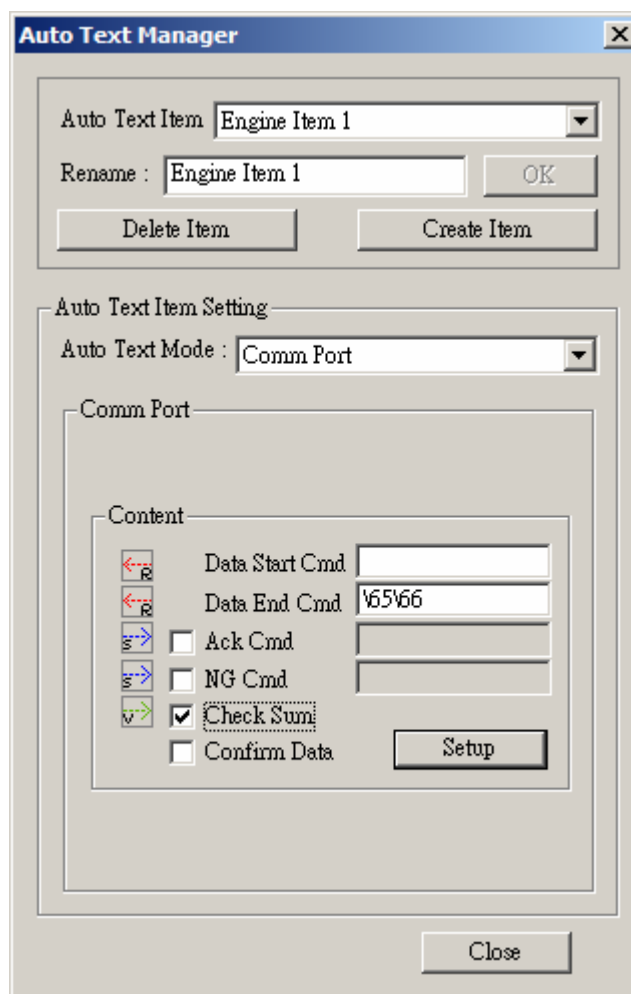

MarkingMate

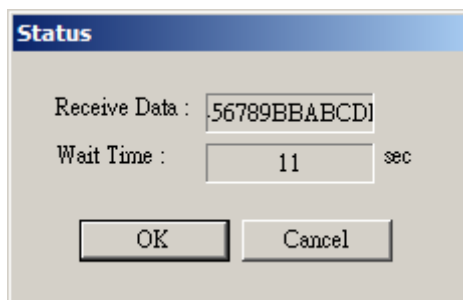

If the checkbox is unchecked, the Status dialogue box will close automatically whenever receiving a correct data and will mark it out directly. Before receiving correct data, the status will keep on waiting as below:

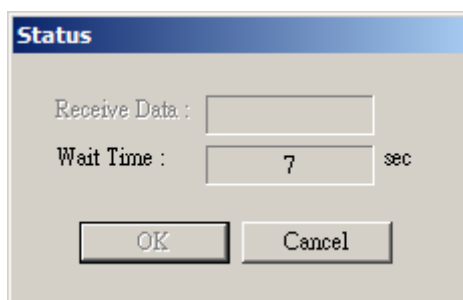

Setup: another dialogue box will appeared as below for users to do advanced setting for Comm Port.

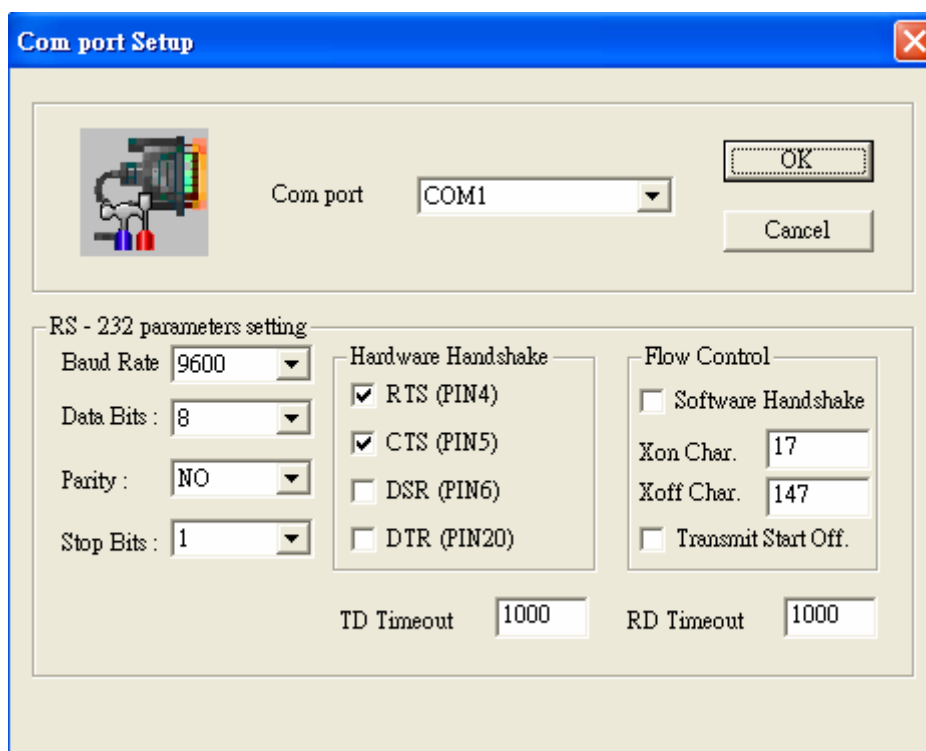

MarkingMate

The transmission between Software and Control-End

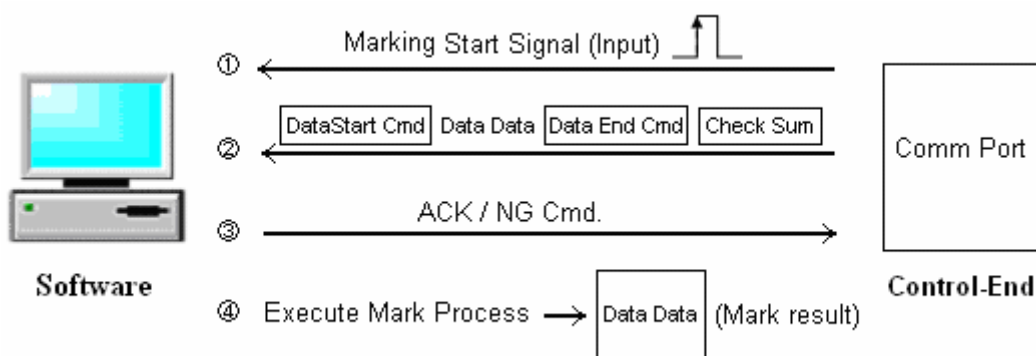

After finishing setting of Auto Text, still can enable or disable “Auto Mark” when entering “Execute” dialogue box for marking:

1. **Disable “Auto Mark”** – When “Auto Mark” is disabled in the “Executing” dialogue box and executing marking function, a “Status” dialogue box will appeared to wait for transmitting data and show the waiting time. If the “Confirm Data” checkbox has been checked during the settings of auto text, the data can be marked only after users pushing the “OK” button. If unselect “Confirm Data” checkbox, the status dialogue box will automatically close and executing marking once receiving a complete data. And when marking finished, the marking of auto text is end and will go back to the “Executing” dialogue box. Before receiving a complete data, the system will keep on waiting and showing the waiting time until a correct data sending in or users pushing the “Cancel” or “ESC” buttons.
2. **Enable “Auto Mark”** – When “Auto Mark” is enabled in the “Executing” dialogue box and execute marking function, the system will show the “Status” dialogue box too. And if the “Confirm Data” checkbox has been selected during the auto text settings, users will have to push “OK” button before marking the data. If unselect “Confirm Data” checkbox, the system will close the “Status” dialogue box and mark it once receiving a complete data. And after marking will automatically open the “Status” dialogue box again to wait for next transmission. At this time, users can send another data or push “Cancel” or “ESC” button to close the marking of auto text.

The Flow Chart of Auto Text Marking

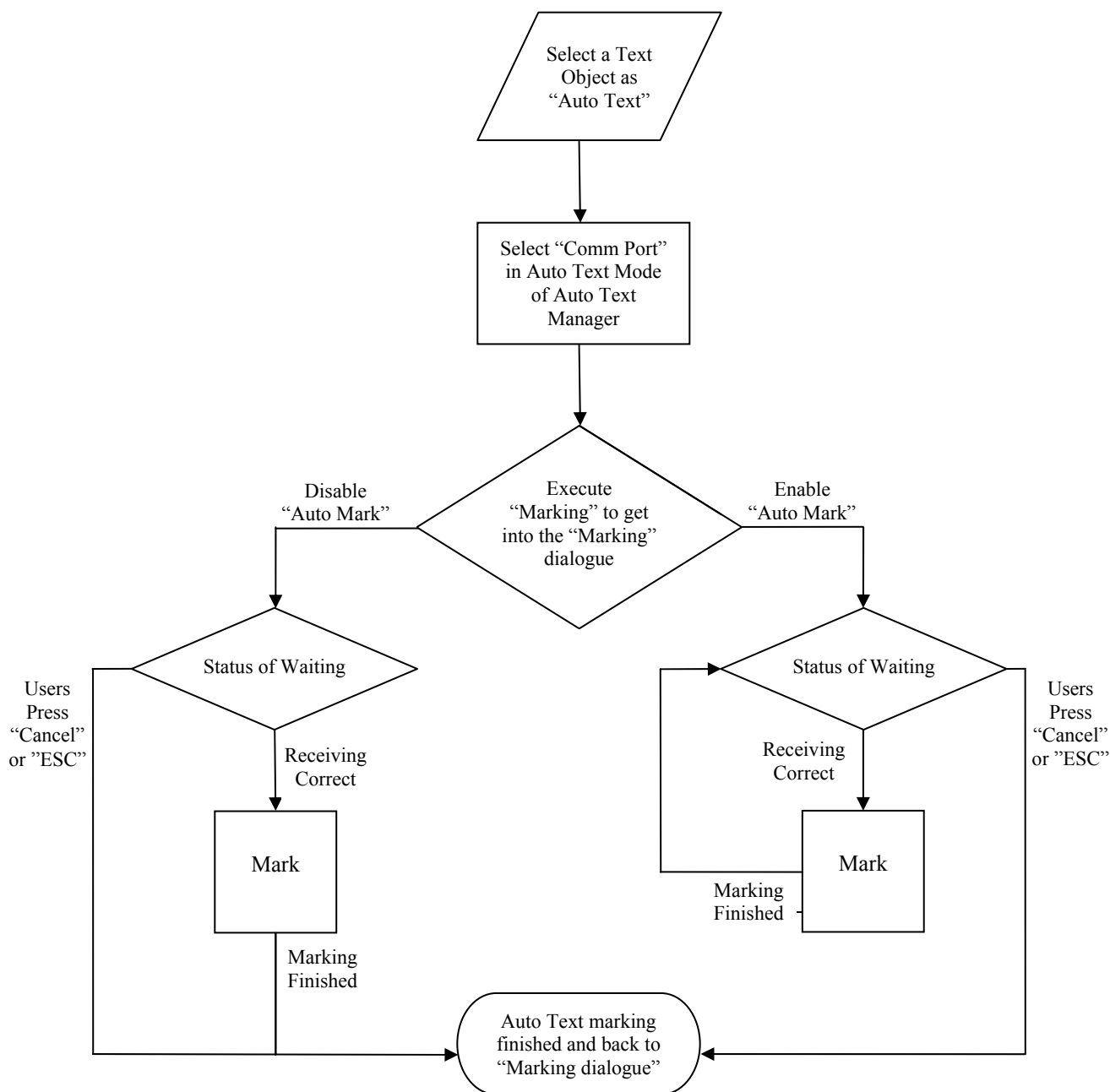

2.5.2.2 Multi Auto Text Setting

If you want to create two text objects with Serial No. and Date of Auto Text separately, please follow the directions as below:

Step 1: First create a Text object and select it, go to the Text page in Property Table (as below), check the box of "Auto Text", the "Auto Text Manager" will appear as below:

MarkingMate

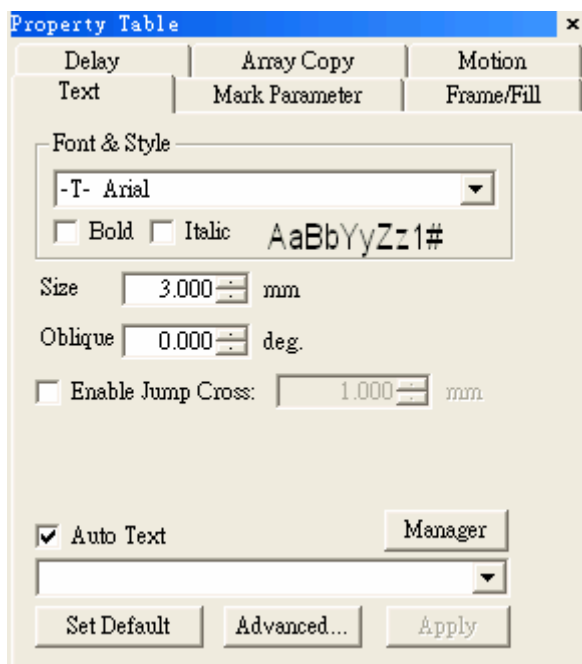

Step 2: The first Auto Text Item has been set as “Serial No.”. Don’t change it. Press the “Create Item” button to create the second Auto Text Item, and change its mode as “Date”, and then press “Close” button.

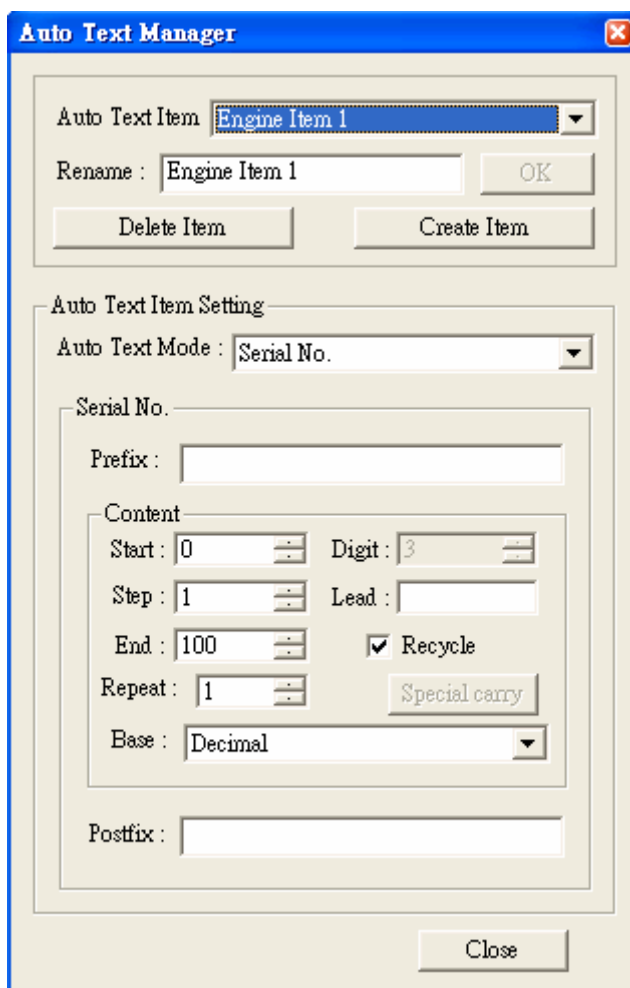

MarkingMate

Step 3: Go to the Text page of Property Table, press the “Advanced” button, and the “Text Advance Setting” page will appear as below. Now you can edit the text contents you want in the blank area. For example, first input “No.:” and then select “Engine Item 1” from the “Insert Auto Text Item” pull down menu. You will see “\[1]” in the blank area which represent the first Auto Text Item you just inserted. After that, input “—Date:” and then select “Engine Item 2” from the “Insert Auto Text Item” pull down menu. You will see “\[2]” in the blank area representing the second Auto Text Item you inserted.

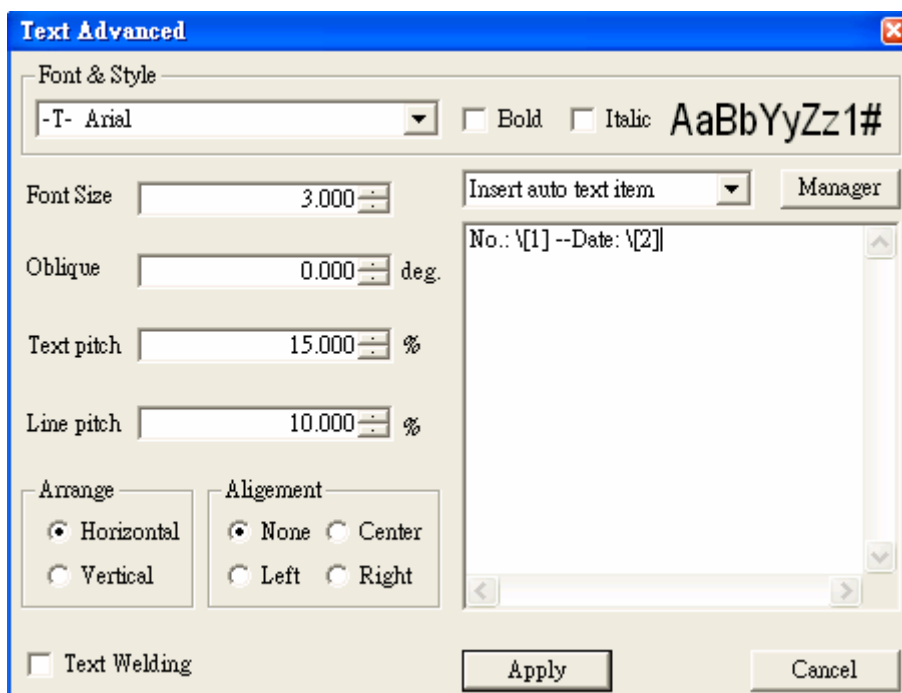
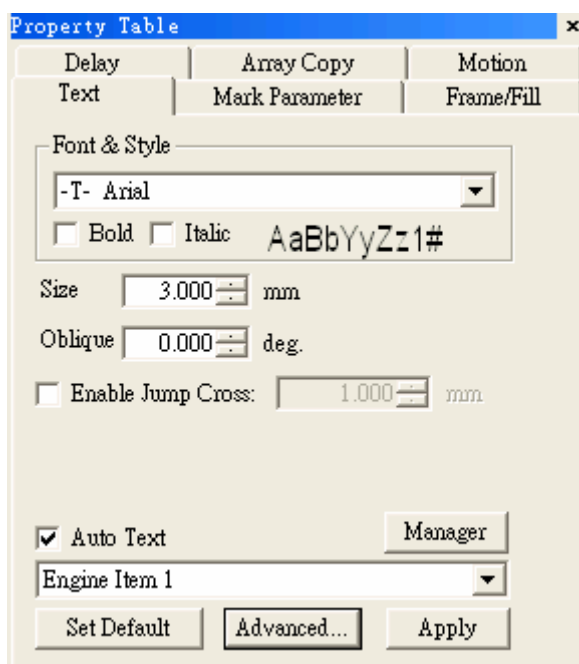

MarkingMate

◆ Serial No. Advance

User with further requirements for Serial No. can choose to use “Serial No. Advance”. This part of descriptions is in the **Appendix F: Auto Text -- Serial No. Advance.**

The screenshot shows the 'Auto Text Manager' dialog box. At the top, 'Auto Text Item' is set to 'Engine Item 1'. Below it, a 'Rename' field also contains 'Engine Item 1' with an 'OK' button. There are 'Delete Item' and 'Create Item' buttons. The 'Auto Text Item Setting' section has 'Auto Text Mode' set to 'Serial No. Advance'. Under this mode, there is a 'Prefix' field, a 'Content' section with several spinners: 'Start' (0), 'Base' (10), 'Step' (1), 'Digit' (0), 'End' (100), 'Lead' (empty), 'Current' (0), 'Repeat' (1), and 'Already repeated' (0). There is a checked 'Recycle' checkbox. A 'Postfix' field is at the bottom, and a 'Close' button is at the very bottom.

◆ TCP/IP

This function is not open as default functions. If users need to input the Auto Text contents from TCP/IP will need to contact us.

The screenshot shows the 'Auto Text Manager' dialog box with 'Auto Text Mode' set to 'TCP/IP'. The 'Auto Text Item' is 'Engine Item 1'. The 'Rename' field contains 'Engine Item 1'. The 'Content' section under 'TCP/IP' has 'Local IP' (192.168.1.245), 'Server IP' (192 . 168 . 1 . 245), and 'Port' (1234). There is an unchecked 'Confirm Data' checkbox. The 'Prefix' and 'Postfix' fields are empty.

MarkingMate

2.5.3 Combine/Break

Combine-

Step 1: Click “File – New” from Menu Bar, or click the  button from toolbar directly.

Step 2: Click “Draw – Circle” from Menu Bar, or click the  button from toolbar. Draw any figure in the Work Area; fill in all objects (as Figure 1 below). Now you can see all objects are circles in Object Browser (as Figure 2 below).

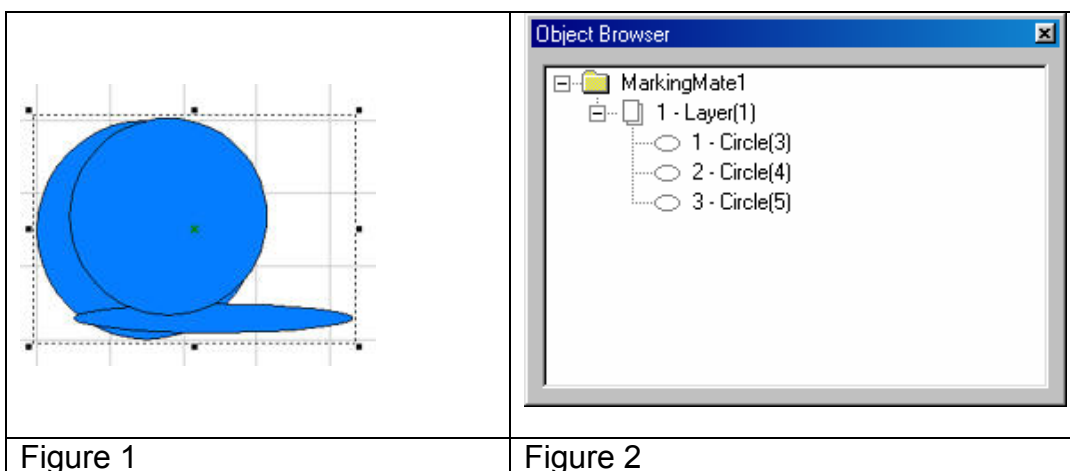

Step 3: Select the object you want to edit, click “Edit – Combine” from Menu Bar. This will make the overlapping part become a hollow (as Figure 3 below), and then you can see the object in Object Browser has become a curve (as Figure 4 below).

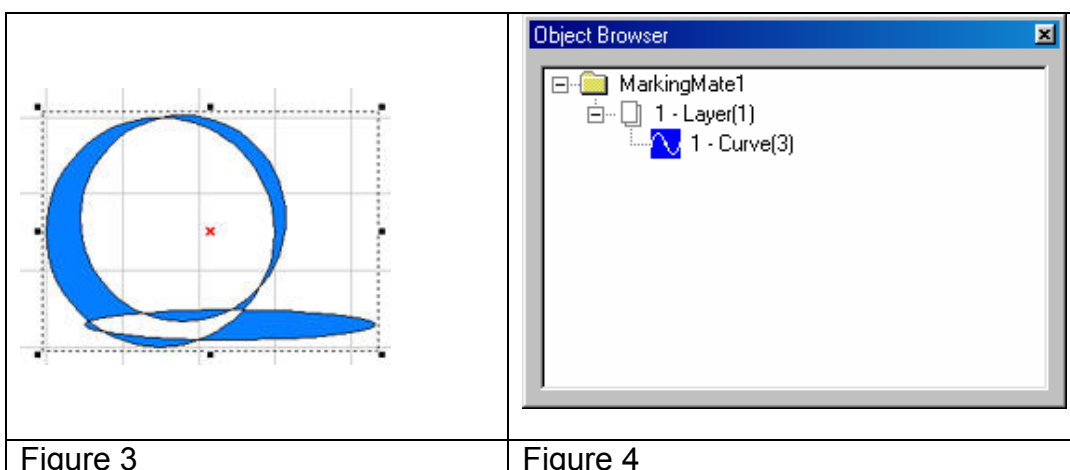

MarkingMate

Break-

Step 1: If want to separate the combined objects, you can use “Break” function. Click “Edit – Break” from Menu Bar. All objects will go back to what they was original (as Figure 5 below), however, they are remain curve (as Figure 6 below).

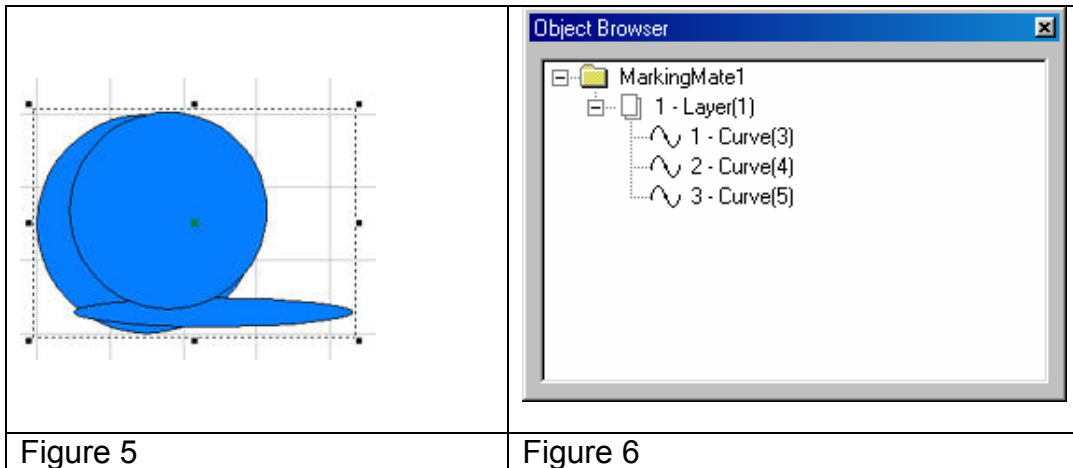

MarkingMate

2.5.4 Group/UnGroup

Group-

Step 1: Click “File – New” from Menu Bar, or click the  button from toolbar.

Step 2: Click “Draw – Circle” from Menu Bar, or click the  button from toolbar. Draw some circles in Work Area and fill colors in all objects (as Figure 1 below). You can see that all objects belong to circle in Object Browser (as Figure 2 below).

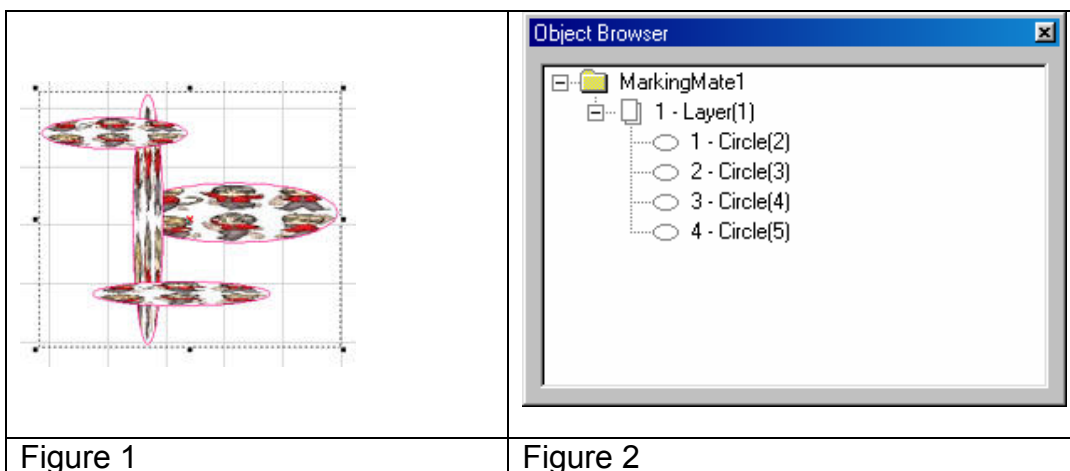

Step 3: Select the objects you want to edit, click “Edit – Group” from Menu Bar, or click the  button from toolbar. The selected objects have become a group. Use ctrl key and select the individual object still be able to edit objects by individual (as Figure 3 below). At this time, you can see the object type in Object Browser has become a group object; however, each individual object is still visible in Object Browser (as Figure 4 below).

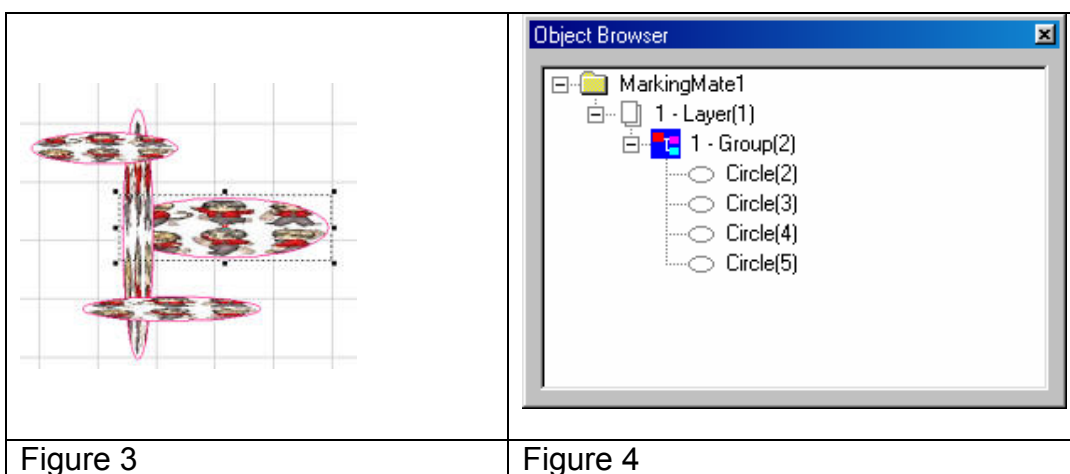

MarkingMate

UnGroup-

Step 1: Use Ungroup function is able to break up a group object. Click “Edit – UnGroup” from Menu Bar, or click the  button from toolbar, all objects will go back to their original look (as Figure 5 below), and their object type as well (as Figure 6 below).

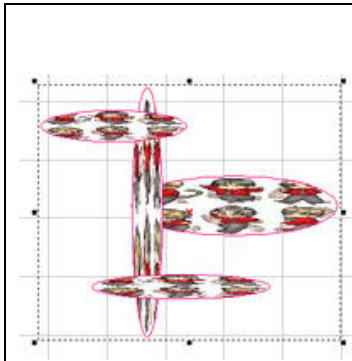

Figure 5

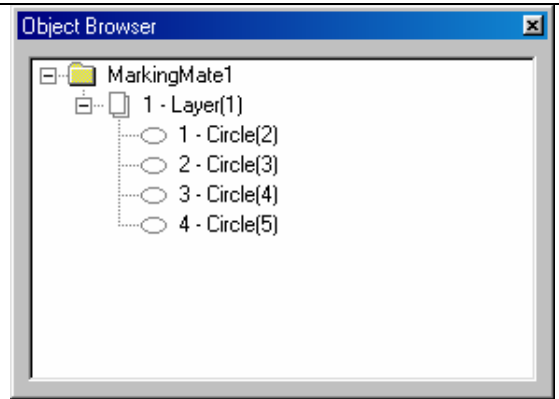



Figure 6

MarkingMate

2.5.5 Sort

Step 1: Click “File – Import” from Menu Bar, or click the  button from the toolbar.

Step 2: Select the file you want to import and then press the “Open” button.

Step 3: The imported file will be as Figure 1 below. User is unable to fill color in this object because it is not a close-loop object (as Figure 2).

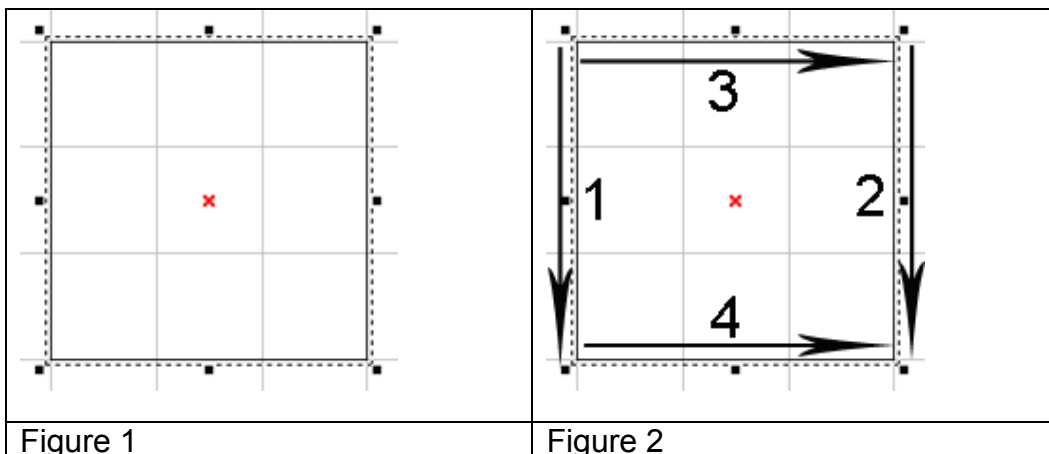

Step 4: Click “Edit – Sort” from Menu Bar or click the  button from the toolbar, the object path will be rearranged to be a close-loop object (as Figure 3 below).

Step 5: Select the object and go to the “Fill” page of the Property Table, choose the color you want and press “Apply” button, the object will be filled in the color you chose (as Figure 4 below).

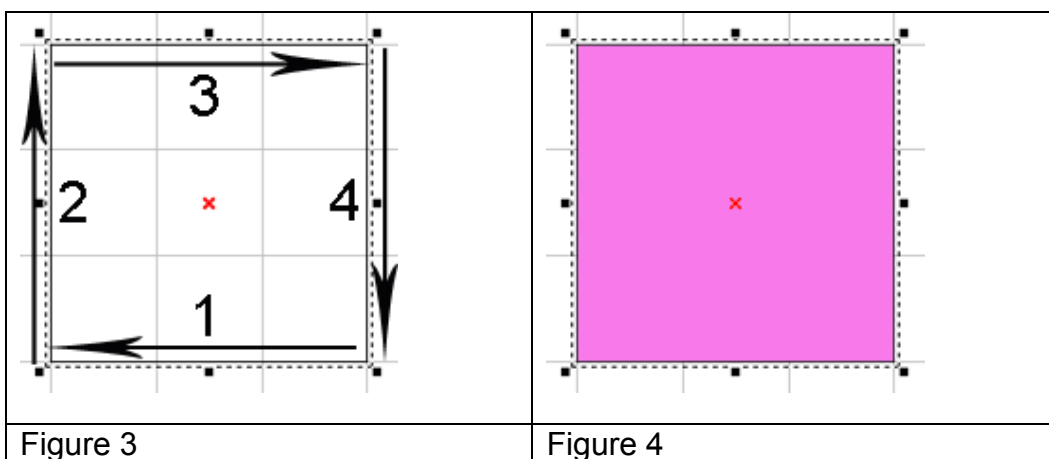

MarkingMate

2.5.6 Rotary Axis Marking (optional)

Step 1: Click “File - Import” will appear the Import dialogue box.

Step 2: Select the file you want to import then click “Open” button.

Step 3: Edit the object properties in Property Table:

(1) Frame/fill – Adjust the color of the border and interior shading of a selected object.

(2) Click  button on the Tool Bar to move the object to the center.

Step 4: Click the layer of the object in the Object Browser and go to the Rotary page of the Property Table for parameter settings.

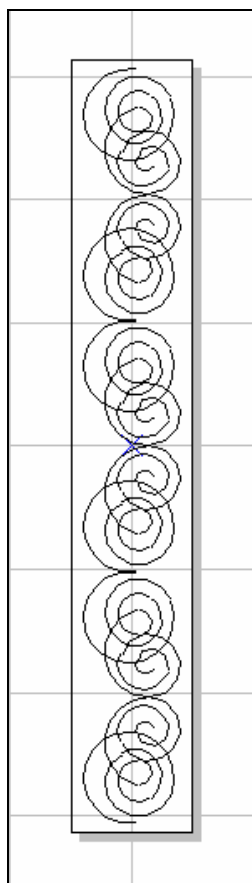

MarkingMate

Enable: Enable the rotary axis function.

Method: the rotary axis mode.

Cylinder: the cylinder mode.

Disc: the disc mode.

Option: parameter settings

Diameter: the double distance between the object to the axle center.

Max Width: the suitable marking range, the value should be changed depend on the diameter.

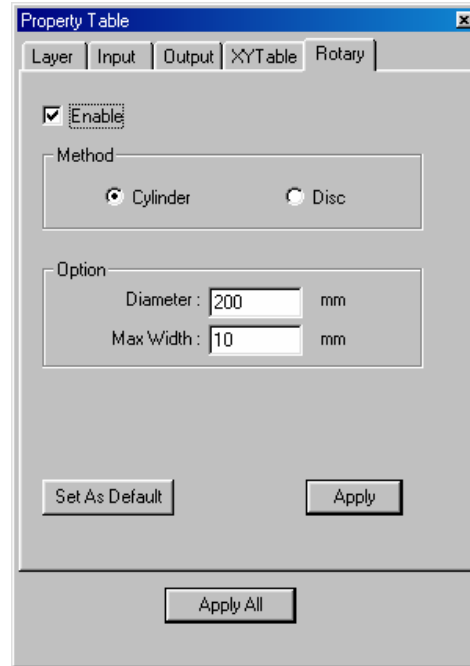

Step 5: Cancel the object selection and go to the motor setting page of the Property Table to do the Motor Setup.

(1) Select the axis you want:

Rotary or X-Axis or Y-Axis or Z-Axis

Unit: angle or length

Acc. Time: the time for Rotary Axis to reach the speed you want. If the value is 5 sec and the speed is 10 degree/sec that means the rotary axis will reach 10 degree/sec in 5 seconds.

Speed: the speed of Rotary Axis. If the value is 10 degree/sec that means the Rotary Axis turns 10 degree per second.

Axis Unit: the pulse amount needed for one circle rotating

If the spec. of the motor is 20000 pulses; the value should be set as 20000 pulses/REV

Start Speed: Start speed of the motor

Reverse: The motor turns in the reverse direction.

Homing After Program Start: Automatically go home after program start

In Position High: Set the signal of In Position as High

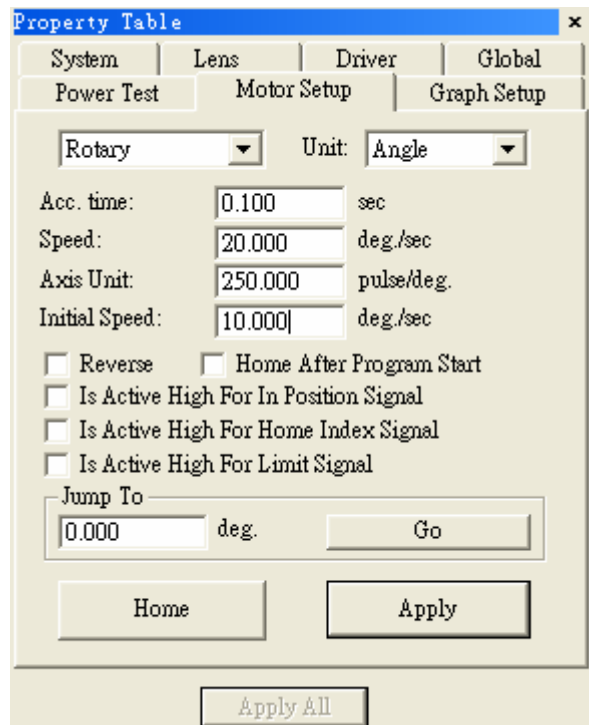

MarkingMate

Home Index High: Set the signal of Home Index as High

Limit High: Set the signal of Limit as High

Jump to: Move to the assigned position

Home: Do the Home action immediately

Step 6: Marking Parameter Setting – Set the mark cycle to Single Pass.

Step 7: Click "Execute - Mark" will appear the Execute dialogue box; and then click "Exec" button, the current status of each Auto Text will be displayed.

MarkingMate

Chapter 3 Laser Marking Function Introduction

MarkingMate is a general laser marking system with capability of supporting various laser marking equipments includes CO2 and YAG laser. As the compatible laser machines please inquire to the laser system vendors.

The principal part of MarkingMate is its drawing editing function. There are many tools include toolbox, ruler, grid, zoom in and MarkingMate is a platform that can be upgraded to be a professional CAM/Control system by adding related modules (for example, the CAM module).

3.1 System Diagram

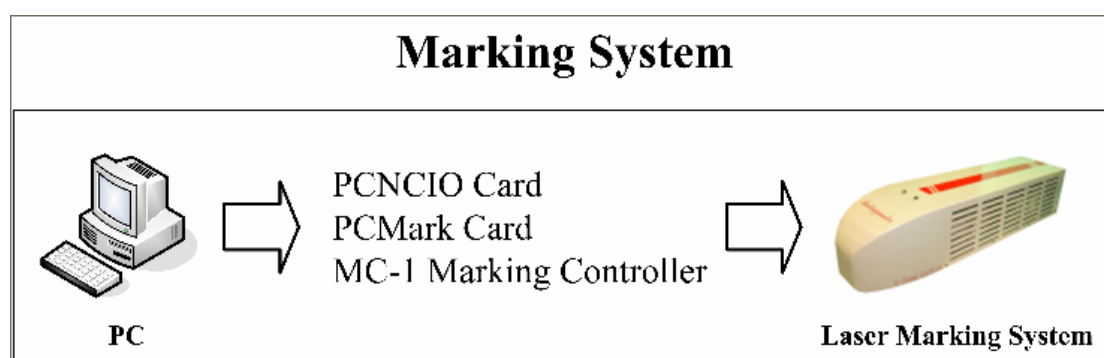

System Main Function:

Composition Function	Allow users to arrange various objects in suitable position
Object Path arrangement and Control	After the path settled, the system will control the GALVO motor through the D/A signals
Laser Source Control	The system can control the strength of laser source by PWM signal or D/A signal

3.1.1 Composition Function

Users are able to import files to the system or using the convenient function this system provide to draw a basic figure. Acceptable file formats include vector files (as DXF, and HPGL), and image files (as BMP, TIFF, JPG, and etc.)

You can draw lines, arcs, circles, curves, texts, 1D barcode, and 2D barcode in

MarkingMate

this system, and base on these drawing to create any figures you want. In addition, you can import an image file or import the picture from scanner.

Moreover, the system supports auto text (include serial numbers, text file, keyboard key-in, and date time). And the system also allows users to insert some wait or judge instructions to solve the problems may be occurred during production.

3.1.2 Object Path Arrangement and Control

After finishing the design job, the work will be marking. Following we will discuss the two parts of the work, the motor control and the laser control separately. First of all is regarding some basic questions on motor control.

GALVO motor is controlled by voltage. For instance, some GALVO motor's rotate angle is ± 20 degree, its acceptable voltage arrange is $\pm 10V$. If the input voltage is $-10V$, motor degree is -20 degree; when the input voltage turns to $0V$, motor degree is 0 degree; while input voltage is $10V$, motor degree become 20 degree. Through the motor degree and focal length can determine the motion of the motor in one axis. Therefore, two motors are able to control the motion in X- and Y-axis.

The GALVO motor's reaction is fast. The motor can shift to the right place around $3ms$ after adding a voltage (according to different brands, and different models). Therefore, suppose there is a line start at $(0, 0)$, and end at $(100, 0)$; the voltage at $(0, 0)$ is $(0V, 0V)$; and the voltage at $(100, 0)$ is $(10V, 0V)$; if the system output $(0V, 0V)$ voltage ate time 1, and output $(10V, 0V)$ ate time 2, we can image that the motor has been moved from $(0, 0)$ to $(100, 0)$!

However, that resulted in few questions. First, how long is the time difference between time 1 and time 2? Before answer this question, you have to consider how fast you want form marking?

$$\text{Time} = \text{Distance} / \text{Speed}.$$

So we got time differences. Assume that the time difference is 1 second, we input $(0V, 0V)$ at time 1, and after one second we input $(10V, 0V)$; the engraving result will be as below:

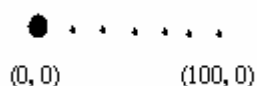

The reason why a black point occurred at $(0, 0)$ is that the system stay a long time at this position. As the dotted line between $(0, 0)$ and $(100, 0)$, it was because the laser output speed (frequency) is slower than the moving speed. In the other word, although the system has followed user's request, the result was not as we expect. The way to solve this problem is inside-insertion. It means that we cut the line between $(0, 0)$ and $(100, 0)$ into many small line segments, for example 1000 line segments, every $1/1000$ second, we

MarkingMate

increased voltage to 10/1000 V. After one second, the motor will move to (100, 0), and the figure will be as below:

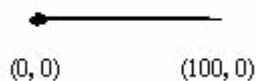

Now the line has become better, only some exceptions at the start and the ending parts. This is because that no matter how fast the motor was, it still a little behind the instruction. And all motions start from static need an acceleration to reach the required speed, and need deceleration to reach the stop position at the ending point. It makes laser stay longer at the start point and stop slowly after laser off. That explains why the laser leaves a heavy point at the beginning and become weak at the ending.

MarkingMate system will provide related parameters for users to avoid these problems and reach the excellent quality. The settings of parameters please refers to the description of section 6.2.3 Delay.

3.1.3 Laser Source Control

The control of Laser Source depends on the systematic difference, some of them are controlled by pulse signals, and some of them are controlled by voltage signals or even controlled by the commands via RS232C. But no matter what modeling it is, the one that should control are the laser transmission frequency and the power finally.

- **YAG Laser Control**

YAG can shoot the laser right away when receiving a trigger current. If the trigger current higher, the laser will be heavier. Besides, there are two methods for shooting laser, one is continuous wave (CW); the other one is intermittence shooting. Two methods result in different effects. Users have to choose by themselves.

Except pulse frequency, the time of laser shooting can also affects the engraving quality. So the square pulse must be able to modulate the Duty Cycle to get a suitable control.

The laser power is mainly determined by the strength of electric current. For old system, the current is usually to adjust by the knob on a control panel of the machine, but for more new system, often set by software in accordance with machine types.

For the users using PCMark card, the way of setting laser power is go to the directory of C:\Program Files\MarkingMate\Drivers\PCMark_XP\cfg, open the driver file, and set all the parameters values you need under the label of [POWER] as below:

```
[POWER]
WarmUpKeepTime=0.000      Warm up keep time [sec]
```

MarkingMate

WarmUpPower=0.000	Warm up power [%]
WarmUpDelay=0.000	Warm up delay time [sec]
StandbyPower=0.000	Standby power [%]
StandbyPowerDelay=0.000	Standby power delay time [sec]
PowerOnDelay=0.000	Power on delay time [sec]
WorkPower=0.000	Work power initial value [%]
WorkPowerDelay=0.000	Work power initial value delay time [sec]

As the way of setting laser power of MC-1 controller, please go to the directory of C:\Program Files\MarkingMate\Drivers\MC1, execute the “config” application software, and will be able to adjust the parameters as below:

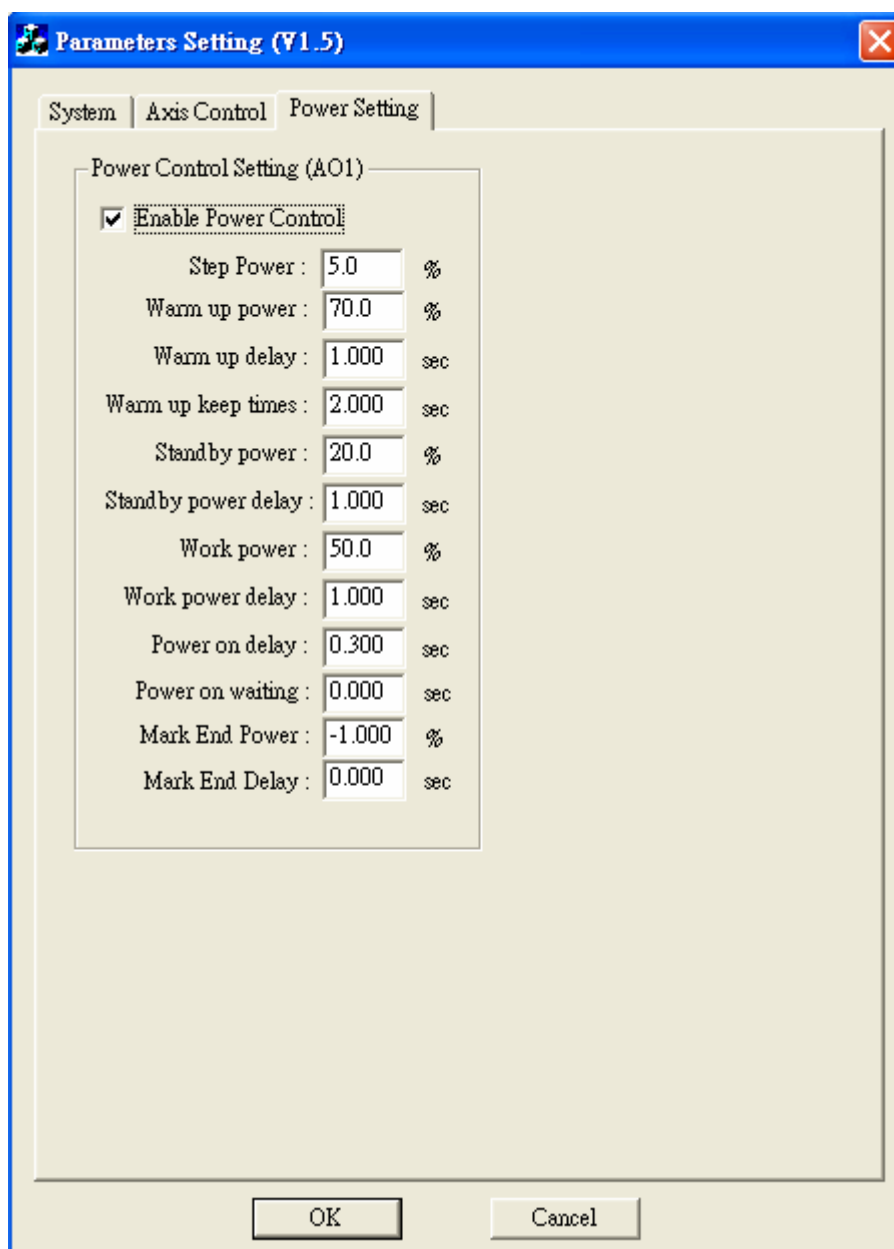

Power Setting

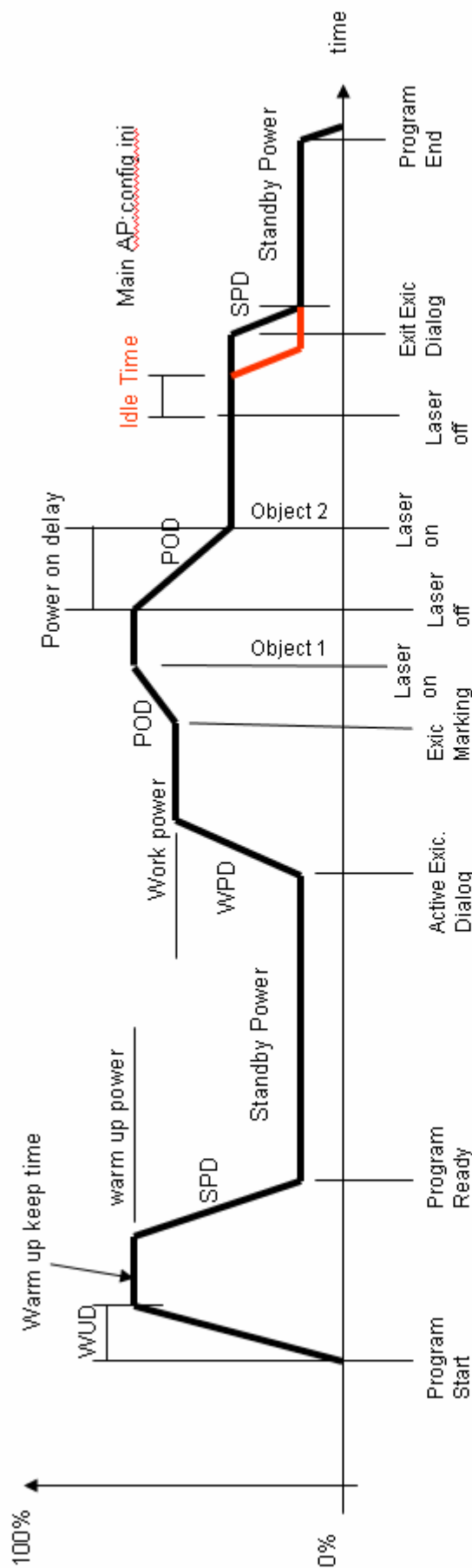

Object 1

Drives : [Config.ini](#)

```
[POWER]
WarmUpKeepTime=2 : [sec]
WarmUpPower=100 : [%]
WarmUpDelay=10 : [sec]
StandbyPower=30 : [%]
StandbyPowerDelay=0 : [sec]
PowerOnDelay=0 : [sec]
WorkPowerDelay=0 : [sec]
WorkPower=0 : [%]
```

WUD : Warm Up Delay
 POD : Power On Delay
 WPD : Work Power Delay
 SPD : Standby Power Delay

MarkingMate

- **Power Saving Control**

When a YAG system (especially a Lamp Pump system) is idle, if we can low down the tube current, will save power and extend the life span of the tube.

The system provides two power saving modes: one is to set **Idle Time**, the other is to set **Idle Time2**.

As the above figure, if the **Idle Time** is not equal to -1 (-1 means inactive), then the system will start the power saving mode one during the period of showing mark dialogue. When exiting the mark dialogue box, the system will drop the power to Standby Power, and when entering the mark dialogue box, the power will be upped to Work Power and start to count time for sleeping mode. If users do not press the “Mark” button after exceeding the Idle Time, then the system will go sleeping mode and low the power to the Default Power.

The **Idle Time2** is different from **Idle Time**. The **Idle Time2** will start to count time for going to sleep when Mark End or Laser Off. And will stop counting when Laser On or start Marking.

Please note that if **Idle Time** and **Idle Time2** are both not equal to -1, the system will follow the setting of **Idle Time2**.

Below is the description of the setting for **Idle Time2** in the file of C:\Program Files\MarkingMate\config.ini:

```
[ENV]
Idle Time2=-1          The time between Mark End and sleep mode
PowerRisingTime=-1    The time rising from 0% power to 100% power[sec]
PowerRisingDelay=-1   The delay time after rising from Standby power to object
power[sec]
DefaultPower=10       The power percentage in sleeping mode[%]
(Default value -1 means inactive)
```

- **Power Setting of Idle Time2**

The below figure is the power setting of **Idle Time2**:

MarkingMate

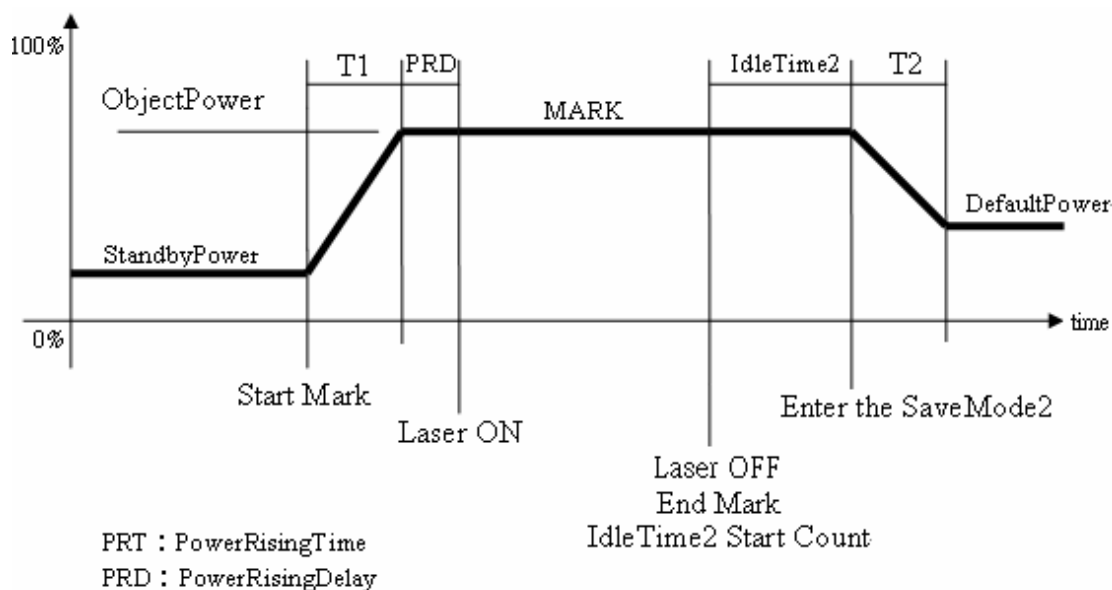

PRT Formula:

$$T1 = (\text{Object Power} - \text{StandbyPower}) * \text{PowerRisingTime}$$

$$T2 = (\text{Object Power} - \text{DefaultPower}) * \text{PowerRisingTime}$$

For example:

Object Power = 50%
[ENV]
StandbyPower=20%
PowerRisingTime=10sec
PowerRisingDelay=4sec
DefaultPower=30%
IdleTime2=5sec

The process of Idle Time2:

1. The system needs 3 seconds (T1) to reach the Object Power we set when laser on. The value of T1 was calculated as follows:

$$T1 = (50\% - 20\%) * 10 \text{ sec} = 3 \text{ sec}$$

2. The system needs 4 seconds (PRD) after reaching the power to make the power stable.
3. After Mark End, start to count 5 seconds (Idle Time 2).
4. The system goes sleeping after 5 seconds, and will take 2 seconds (T2) to low the power down to 30% (DefaultPower). The value of T2 was calculated as follows:

$$T2 = (50\% - 30\%) * 10 \text{ sec} = 2 \text{ sec}$$

MarkingMate

- **CO2 Laser Control**

The CO2 laser control is easier. Its trigger and shooting are controlled by a single PWM signal. In general the PWN frequency is between 5K and 15K. And the laser power is determined by the percentage of high voltage of PWM.

When the percentage reaches 100% the laser power is the biggest, while 0% is the smallest. Even the laser is not under shooting, the PWM frequency has to remain on 5K, and the high voltage time needs to be about 1 μ s.

- **SoftPWM Control**

Since the CO2 laser is controlled by PWM signals simply, this system offers a mechanism of allowing software to control CO2 laser. However, users must install PCMark card or MC-1 controller first. And the setting methods are different, we will discuss them separately.

1. PCMark Card

Start the config program in the directory of C:\Program Files \MarkingMate\Drivers\PCMark_XP as Figure A as below, check the item of SoftPWM Enable (255=100%), then there are eight fields being actived to accept modification. These eight fields represent the first eight laser points that we can control. Their default values are 32, 64, 96, 128, 160, 192, 224, and 255. Since 255 represent 100%, therefore, the laser output of the eight points will be increased from 12.5% to 25% to 37.5% to ... to up to 100% at the eighth point finally. Please note that all of these points can be set freely except the eighth point. It is because that all the laser point after the eighth point will be considered as the same as the eighth point, so, if the eighth point were not set as 255 (100%), then all of the laser of the other laser points can not reach 100%

2. MC-1 Controller

Start the config program in the directory of C:\Program Files \MarkingMate \Drivers\MC1 as Figure B as below, put a check on the item of the Enable Softstart, then you can adjust the Power Level (from 0% to 100%) from pulse-1 to pulse-16 separately. After finished, click "OK".

MarkingMate

The image shows a software configuration window titled "PCMark Config" for a CO2 laser. It includes fields for "Item" (co2) and "Laser Type" (CO2). The "CO2" section contains "Tickle" (200 us) and "Tickle Width" (1 us) settings, a checked "SoftPWM Enable (255 = 100%)" option, and a grid of 8 PWM duty cycle values (32, 64, 96, 128, 160, 192, 224, 255). A "Load Default" button is present. A waveform diagram labeled "CO2 LASER (Q-Switch)" illustrates the pulse sequence with "Tickle Hz" and "Tickle Width" annotations. At the bottom, there are fields for "Start Pin" (15), "Stop Pin" (16), "Marking Ready Pin" (14), "Program Ready Pin" (15), and "Marking End Pin" (16), along with "OK" and "Cancel" buttons.

Item	Laser Type
co2	CO2

CO2

Tickle : 200 us Tickle Width : 1 us

SoftPWM Enable (255 = 100%)

1	32	5	160
2	64	6	192
3	96	7	224
4	128	8	255

Load Default

CO2 LASER (Q-Switch)

Tickle Hz Tickle Width

Start Pin :	15	Marking Ready Pin :	14
Stop Pin :	16	Program Ready Pin :	15
		Marking End Pin :	16

OK Cancel

Figure A: PCMark Config

MarkingMate

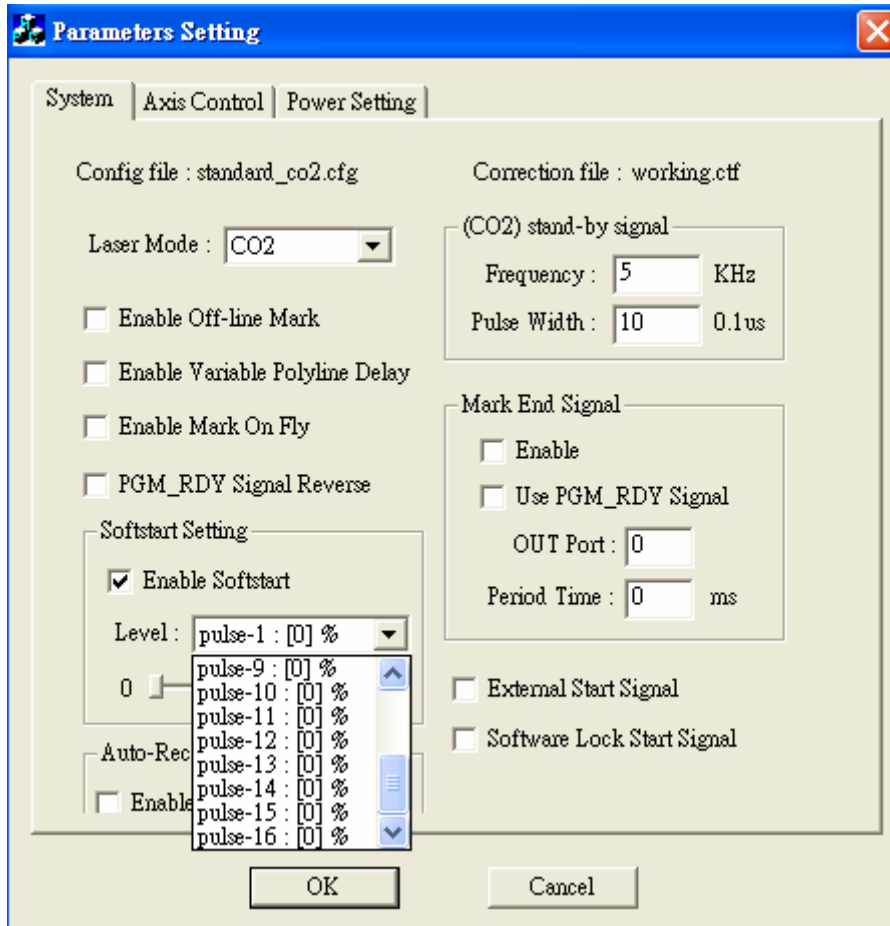

Figure B: MC-1 Config

MarkingMate

3.2 Automation and I/O

If users want to add this system as a part of their production automation, all they need is to realize how the system works with I/O signals and do the right setting.

3.2.1 MarkingMate Signal Time Sequence

Program Ready/Mark Ready

Program Ready and Mark Ready signals are programmable. System integrators are able to plan the signal as Program Ready or Mark Ready signal depending on their requirements.

If set as **Program Ready**, the signal will be “OFF” as computer on, and will become “ON” when entering the program and keeping as “ON” until exiting the software. This signal is mainly planned to tell that the marking program is ready.

When set as **Mark Ready**, the signal will be “ON” when executing “Mark” function, and will be changed to “OFF” if exit the executing dialogue.

Ready for Start Signal

Ready for Start Signal was called “Mark Ready” before. This signal is initially set as “OFF”, when executing Mark function (entering “Exec” dialogue, waiting for “START” signal), the signal become “ON”; after receiving “START” signal, this signal changed to be “OFF”. When an object finished marking, the system go back to the status of waiting “START” signal, then this signal become “ON” again. If users add a control object “DO PAUSE” into their marking files, this signal will also be “ON” and waiting for “START” signal when executing the “DO PAUSE” object. Therefore, as long as this signal become “ON”, it means that the system can sent “START” signal safely.

Stop/Error

This signal is also programmable. In Normal Mode, this signal can be planned as “**Stop**” signal, while in Automation Mode, it can be planned as “**Error**” signal.

In **Normal Mode**, users press “STOP” button to break down the marking process, then the “Ready for Start Signal” will be “ON” and waiting for “START” signal to continue the marking process.

If under **Automation Mode**, once the program detecting the “Error” signal and exiting the “Exec” dialogue, the “Mark Ready” signal become “OFF” as well as the “Ready for Start Signal” and “Marking End” signals. Only if trouble eliminated and reentering “Exec” dialogue, the “Mark Ready” and “Ready for Start Signal” will be changed to be “ON”.

Mark End/Mark End Pulse

This signal is also programmable. Its default setting is Mark End (means

MarkingMate

Mark End Pulse Time= 0, this parameter can be changed in Config.ini, please see the description of Appendix D: Config.ini Settings.)

When set as **Mark End** signal, it was “OFF” originally, when it become “ON” that means the marking process has been finished. The signal can be “OFF” again when the system receives a “START” signal. If the system suspend because of “DO PAUSE” (Ready for Start Signal is ON), and even receive “START” signal again and continue marking process (Ready for Start Signal is OFF), the “Marking End” signal is keeping as “OFF” until the marking job finished.

If set as **Mark End Pulse** signal (Mark End Pulse Time equals some integer value), it was the same as Mark End signal, to be “OFF” at first, and then become “ON” when mark job done. However, the time the signal maintained “ON” was contingent upon the time of Mark End Pulse Time.

Signal Time Sequence (Normal Mode)

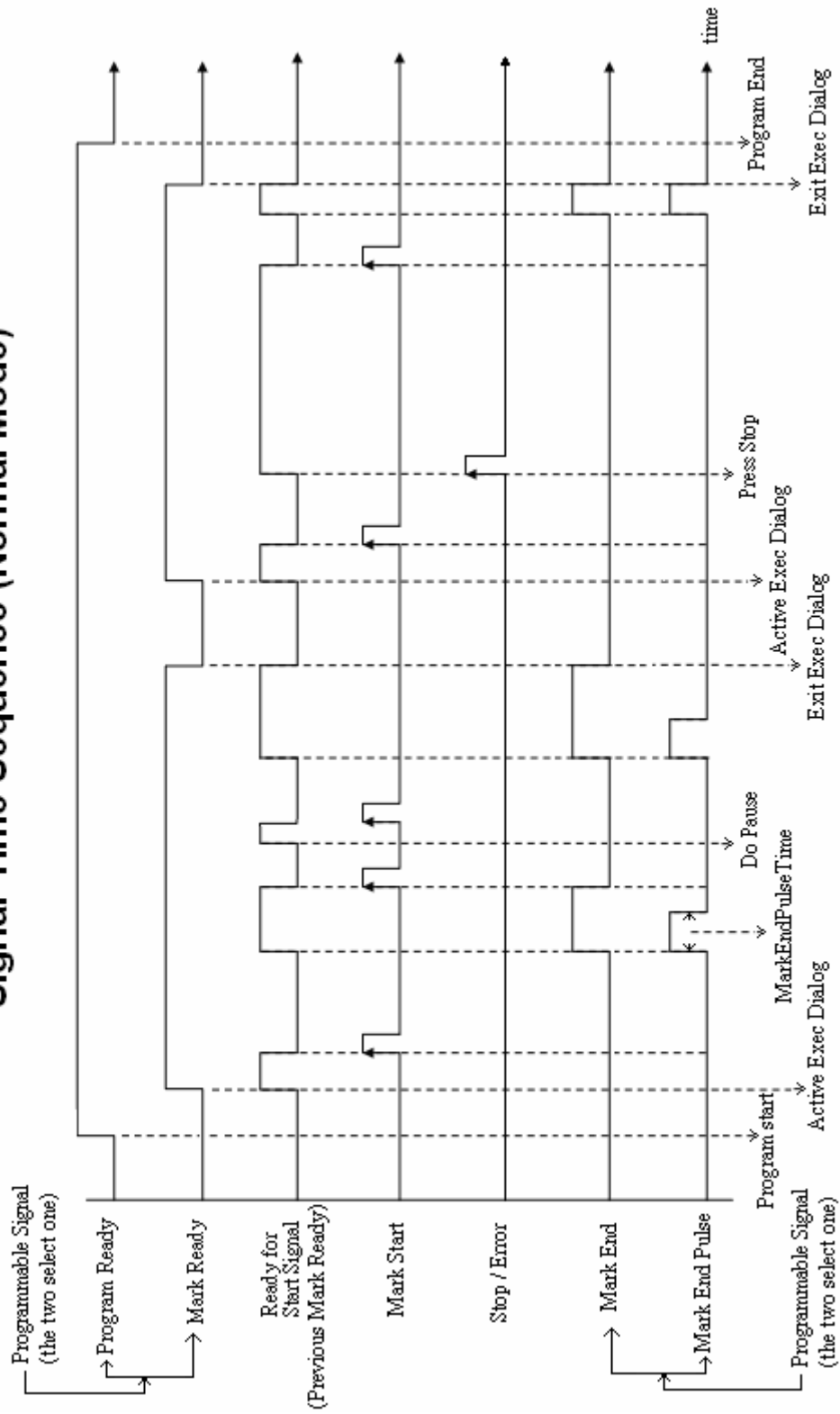

Signal Time Sequence (Automation Mode)

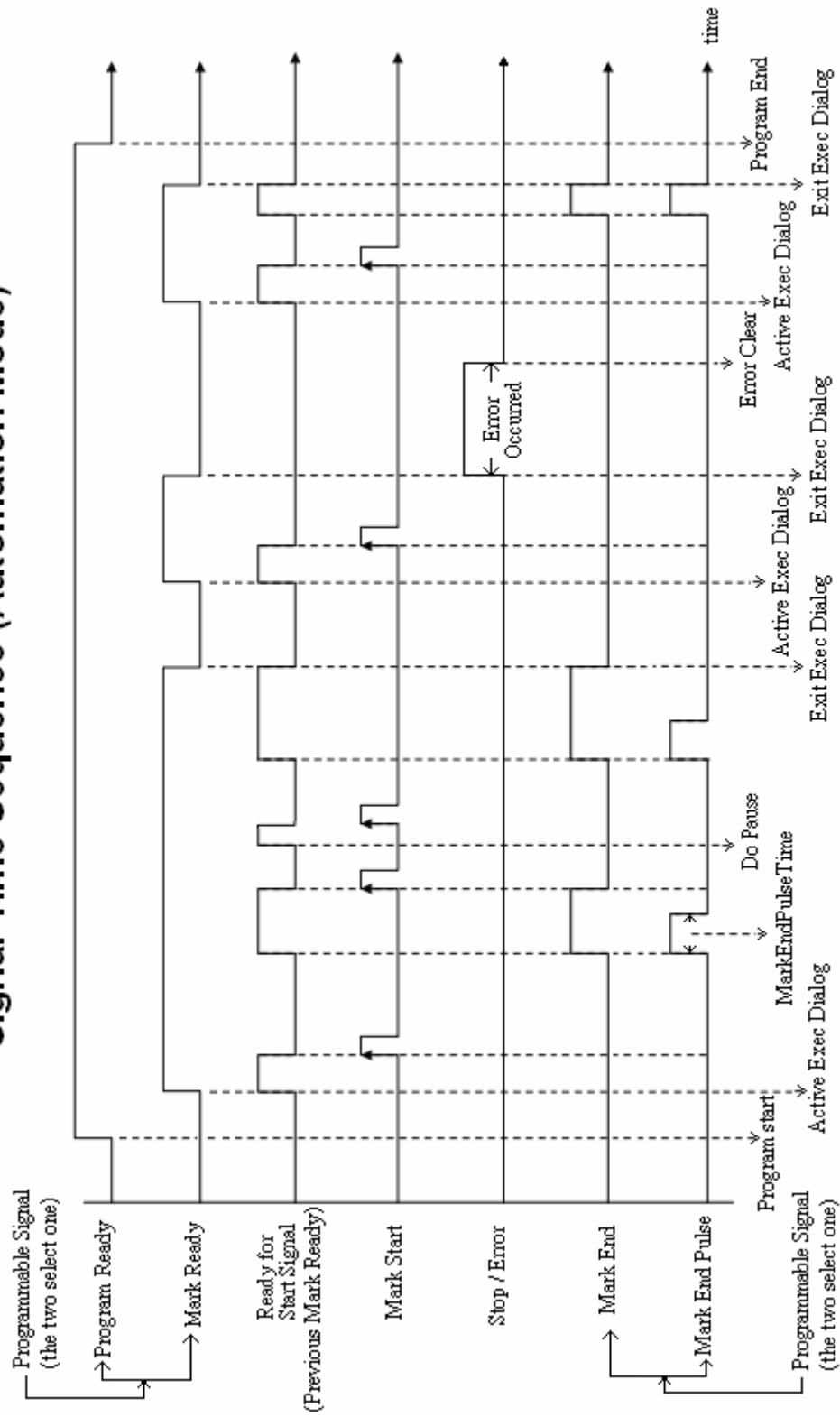

MarkingMate

3.2.2 Error Messages Planning

When this system is used in an automatic process, you can edit some error messages prompt to help users judging how to get rid of mistakes.

1. Activate

Clicking the file of **config.ini** in the directory of C:\Program Files \MarkingMate to open it, modify "MachineChk= 0" to be "MachineChk= 1" and save, then the function is activated. If want to activate the error message prompting, modify "MachineChk_ShowMessage=0" to be "MachineChk_ShowMessage=1" and save the file, then the function is activated.

2. Edit Messages

After activating the function, then go to edit the file of **MachineChk.cfg** in the directory of C:\Program Files \MarkingMate as the following descriptions and save.

Name	Setting method	Description
[I10]		From [I1] to [I16], [I10] means the tenth input
	ENABLE=1	1 means open, 0 means close
	LEVEL = 1	INPUT activated potential, 1 means activated when signal changed from 0 to 1, 0 means activated when signal changed from 1 to 0
	OUTLEVEL= 0	Output potential (0 or 1)
	OUT=3	Output number (0 means no output)
	MSG=Error Message(001)\nX Scanner head failure\nResolve Method: Contact with us	Input the error message after "MSG=" (\n means line feed)
	PRIORITY=6	You can add several different messages for the same I/O; they will show in accordance with priority. Less number means higher priority. (from 0 to 15)
[EMG_STOP]		Emergency Stop
	ENABLE=1	1 means open, 0 means

MarkingMate

		close
	OUTLEVEL= 1	Output potential (0 or 1)
	MSG=Error Message\nEmergency Stop!	Input the error message after "MSG=" (\n means line feed)
	PRIORITY=7	Less number means higher priority. (from 0 to 15)
	OUT=0	Output number (0 means no output)
[GALVO_MOTOR_1]		First GALVO motor error, if scan head supported
	ENABLE=1	1 means open, 0 means close
	MSG_FAIL=X Galvo is unusual	Input the error message after "MSG_FAIL=" (\n means line feed)
	MSG_SUCC=X Galvo is normal	Input the normal message after "MSG_SUCC=" (\n means line feed)
	IN=9	Input number
	LEVEL=1	INPUT activated potential, 1 means activated when signal changed from 0 to 1, 0 means activated when signal changed from 1 to 0
	PRIORITY=10	Less number means higher priority. (from 0 to 15)
[GALVO_MOTOR_2]		Second GALVO motor error, if scan head supported
	ENABLE=1	1 means open, 0 means close
	MSG_FAIL=Y Galvo is unusual	Input the error message after "MSG_FAIL=" (\n means line feed)
	MSG_SUCC=Y Galvo is normal	Input the normal message after "MSG_SUCC=" (\n means line feed)
	IN=11	Input number
	LEVEL=1	INPUT activated potential, 1 means activated when signal

MarkingMate

		changed from 0 to 1, 0 means activated when signal changed from 1 to 0
	PRIORITY=9	Less number means higher priority. (from 0 to 15)
[CONNECT]		Controller connect error, only MC1 Driver support it at this moment
	ENABLE=1	1 means open, 0 means close
	MSG=Error Message\nController connect error\nResolve Method:\nStep 1: Make sure the USB connector is connected well.\n Step 2: Make sure the controller power is on and wired\n Step 3: See if the Emergency Stop is activated\n Step 4: Contact us if the above steps do not work.	Input the error message after "MSG=" (\n means line feed)
	OUT=9	Output number (0 means no output)
	PRIORITY=8	Less number means higher priority. (from 0 to 15)
	OUTLEVEL= 1	Output potential (0 or 1)

Chapter 4 Menu Bar

4.1 File Menu

“File” Menu offers the below functions:

New	Create a new document.
Open	Open an existing mark (.ezm, .mrk, .mrs) file
Close	Close a file
Save	Save the current document using the existing file name
Save As...	Save the current document using an assigned file name
Option...	Edit the default work area, ruler, grid, and other settings
Import	Import a graphics files and convert it into the mark format
Export DXF	Export the file as .dxf file for other applications
Select TWAIN device...	Select the supported scanners
TWAIN acquire...	Scan an image
Config Import	Import the configuration files
Config Export	Export the configuration files
Print	Print the file
Preview	Preview the current document before printing
Printer setting	Select the printer and edit the default printer and paper parameters
Exit	Exit MarkingMate

MarkingMate

4.1.1 New

Create a new document in MarkingMate.

Method:

Click “File” from Menu Bar and select “New” function.

Click the  button from the Toolbar

Press the [CTRL+N] key from keyboard.

4.1.2 Open

Open an existing mark file. The file name can be set in the dialogue box. You can open several files and switch to different document by using window menu.

If you want to create a new document, please use ”New” function instead.

Method:

Click “File” from Menu Bar and select “Open” function.

Click the  button from the Toolbar

Press the [CTRL+O] key from keyboard.

The default document of MarkingMate will be saved as .ezm file format as the below dialogue box.

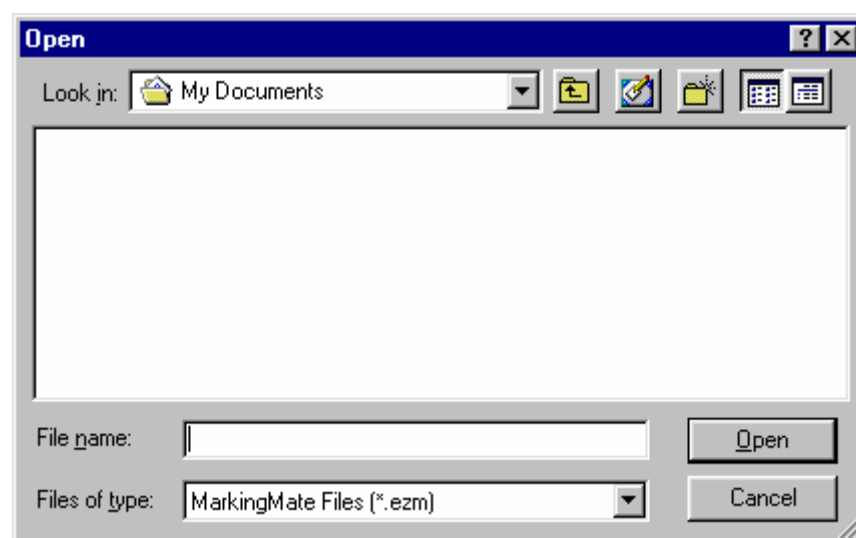

4.1.3 Close

Close the windows in using. MarkingMate suggests you to save the modified file before closing, if you do not save before closing it, you will lose all the modification after last saving.

If close an unnamed file, MarkingMate will open a “Save As” dialogue box for you to named the file.

Method:

Click “File” from the Menu Bar and select “Close” function.

MarkingMate

Click the top-right button as below to close the file:



Click the top-left icon  as below to close the file:

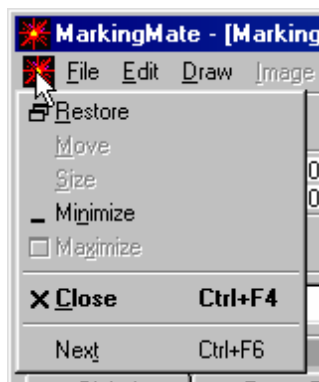

Press the [CTRL+F4] key from keyboard

4.1.4 Save

Save the current document using the existing file name. If there is no file name yet, MarkingMate will open a dialog box of “Save” for you to assign. If you want to change file name or directory, use “Save As” function instead.

Method:

Click “File” from Menu Bar and select “Save” function.

Click the  button from the Toolbar

Press the [CTRL+S] key from keyboard

4.1.5 Save As

Save the current document using a new assigned file name.

If you want to save in its existing file name, use “Save As” function instead. ◦

MarkingMate

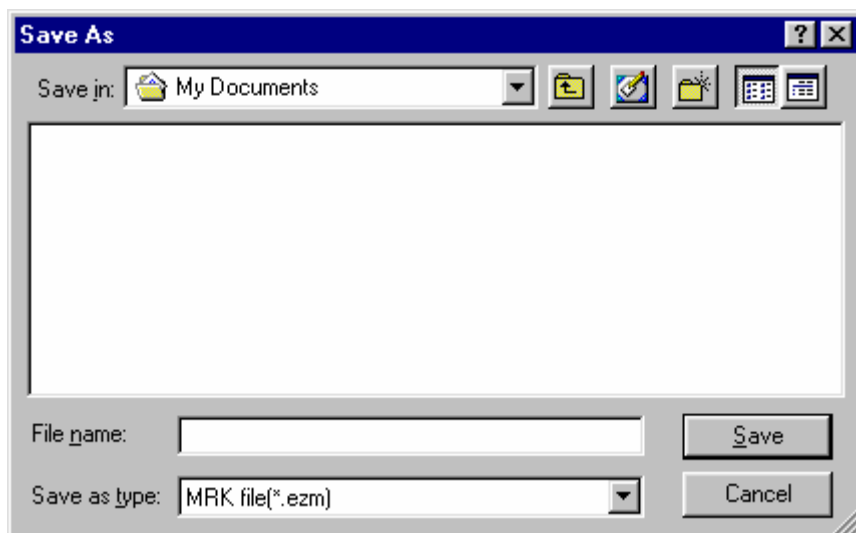

The dialogue box of “Save As” allows you to assign the below items:

Save in: Select the directory you want to save.

File name: Type or select file name.

Save as type: The default file type is **EZM**.

4.1.6 Option

The menu will allow you to edit the default work area, ruler, grid and other settings.

4.1.6.1 System

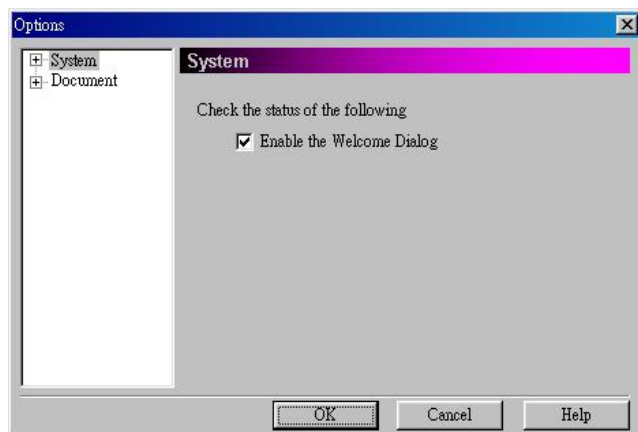

Enable or disable the system settings

4.1.6.2 Welcome

Enable/disable the welcome dialogue box.

MarkingMate



Enable the welcome dialog box
Enable/disable the welcome dialog box.

4.1.6.3 Power Setting

Enable/disable the power settings.

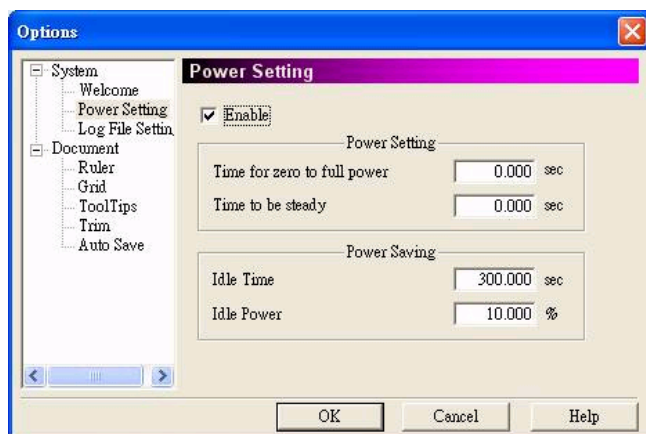

Power Setting
Time for zero to full power
Time period between zero and full power
Time to be steady
After the time will the power become steady
Power Saving
Idle Time
Time period to enter Power Saving mode
Idle Power
Power for Power Saving mode

4.1.6.4 Document

Set the status of the current document.

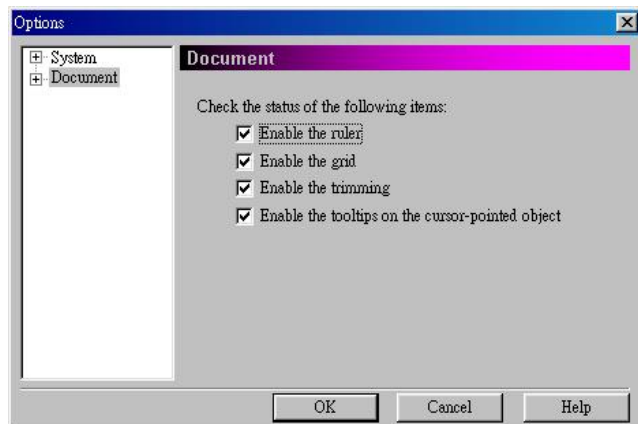

Check the status of the following items.
The setting will be the default setting for next opening document.

MarkingMate

4.1.6.5 Ruler

Enable/disable the ruler appears on the work area.

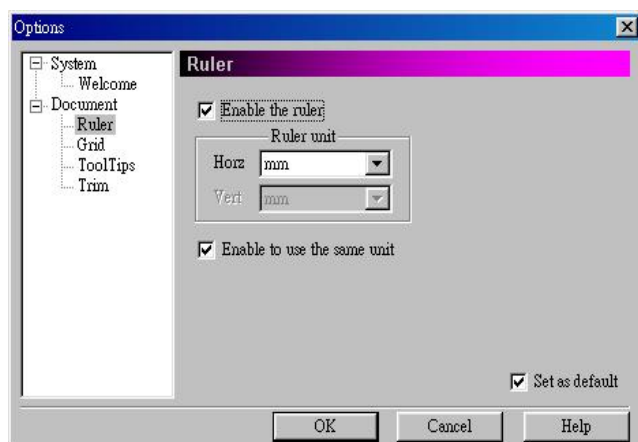

Enable the ruler

Enable/disable the ruler.

Ruler Unit: mm or inch

Horz: Horizontal unit

Vert: Vertical unit

Enable to use the same unit

Enable/disable the horizontal and vertical rulers to use the same unit.

4.1.6.6 Grid

Insert a grid over the work area.

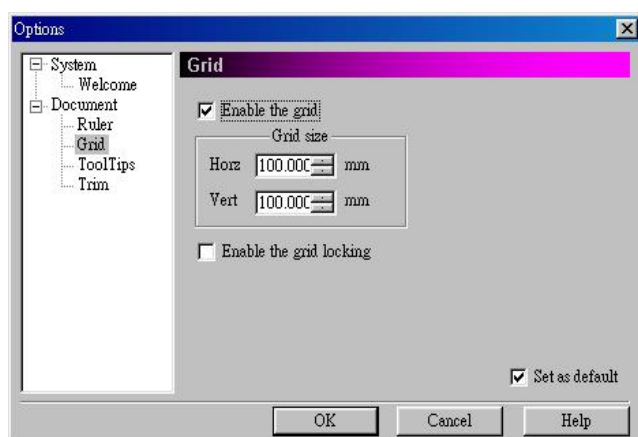

Enable the grid

Enable/disable the grid

Grid size

Horz: Horizontal width

Vert: Vertical width

Enable the grid locking

Enable/disable the grid locking

4.1.6.7 ToolTips

ToolTips is a tool which shows the info of the selected objects.

MarkingMate

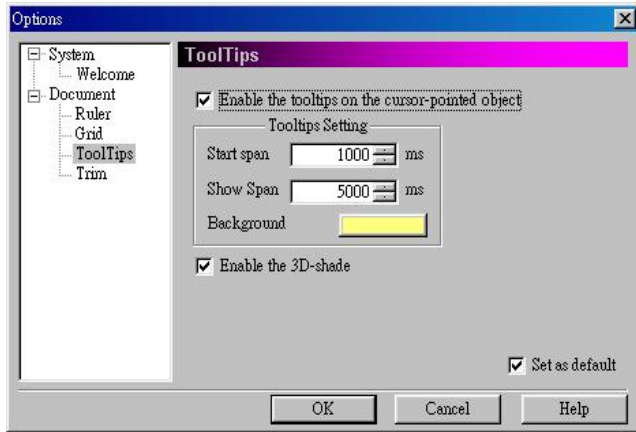

Enable the ToolTips on the cursor-pointed object
Enable/disable the ToolTips
ToolTips Setting
Start span: Span for starting.
Show span: Span for showing.
Background: background color.
Enable the 3D-shade
Enable/disable the 3D-shade

4.1.6.8 Trim

Enable/disable the trim function and adjust the standard unit of trimming.

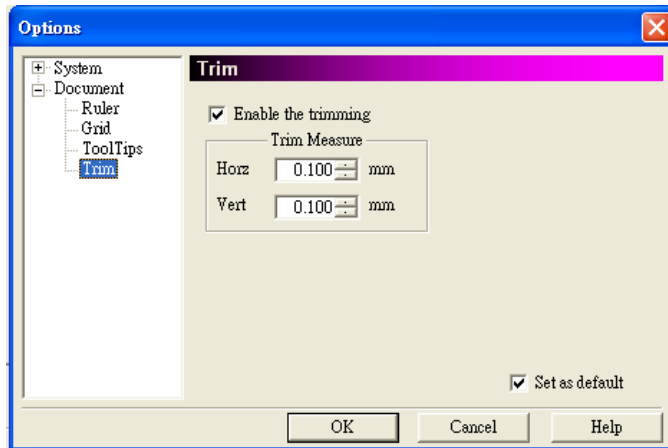

Enable the trimming
Enable/disable the trimming
Trim Measure
Adjust the horizontal and vertical trim measure.

4.1.6.9 Auto Save

Enable/disable the Auto Save function.

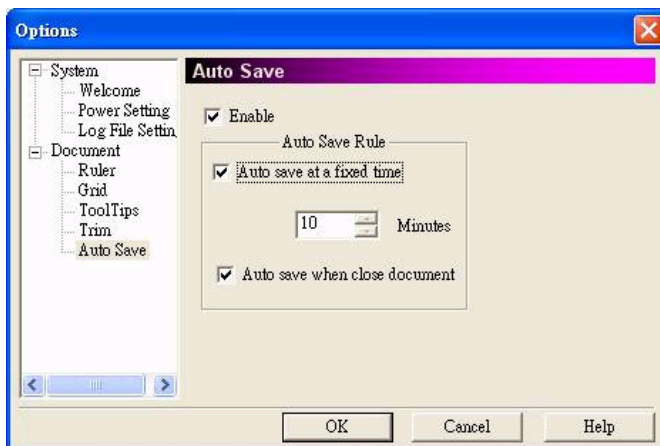

Enable
Enable/disable the auto save
Auto Save Rule
Auto saved at a fixed time
The system will save the documents automatically every time period you entered in the field.
Auto saved when close document
Executing auto save at every time closing the document.

MarkingMate

4.1.6.10 Log File Setting

Enable/disable the log file setting.

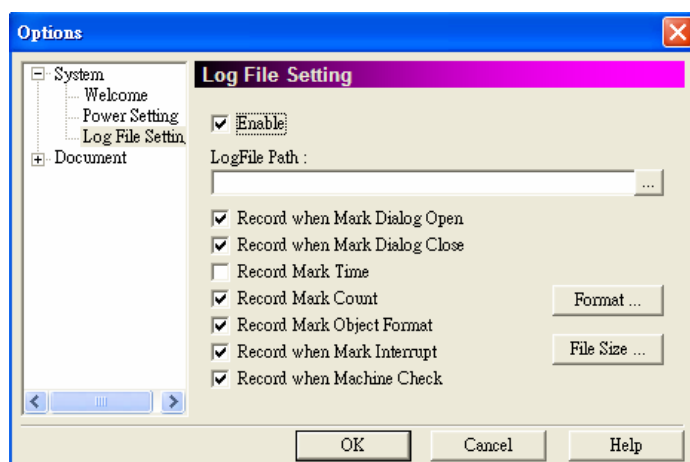

Enable

Enable/disable the log file setting

Log File Path

Select the path of log file by clicking the button .

Record Item

Check the items you want to record. Each item format in the log file can be edited by clicking "Format" button as below:

Mark Dialog Open: Record the message when mark dialog opened.

Mark Dialog Close: Record the message when mark dialog closed.

Mark Time: Record the mark time.

Mark Count: Record the mark count.

Mark Object Format: Record the object format.

Mark Interrupt: Record the message while interrupt happened.

Machine Check: Record the message of machine checking.

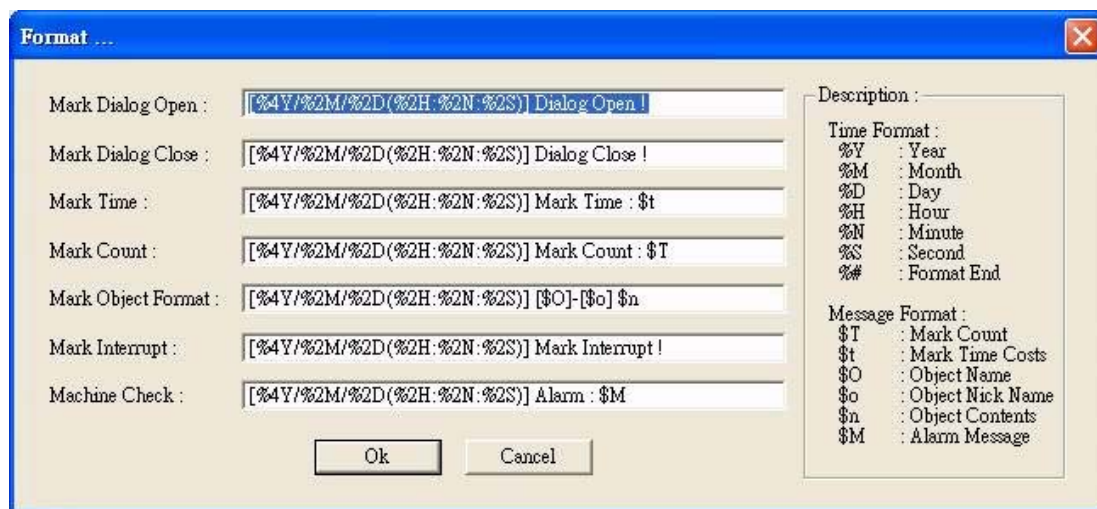

Description:

All of the Time Format and Message Format are listed here.

For example: if a format of Mark Dialog Open set as below:

`[%4Y/%2M/%2D(%2H:%2N:%2S)] Dialog Open ! %%`

Then the log file will be record as:

`[2007/10/15(09:32:24)] Dialog Open !`

Please note that Time Format can be used in every fields, however, the

MarkingMate

Message Format must be placed at the related fields. For example: the Message Format “\$T” (Mark Count) can only be used in “Mark Count” field, if it is placed in “Mark Dialog Open” field, an unexpected result may occurred.

File Size

Press the “File Size” button will see a dialogue box as below. The function is used for editing the log file’s file size and file type.

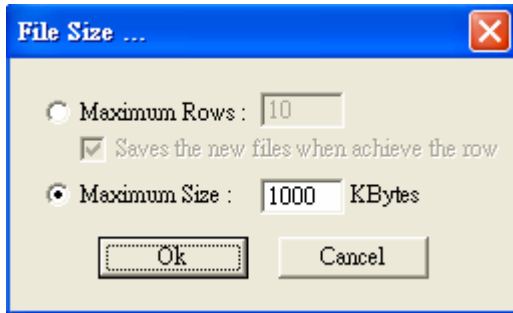

There are four kinds of file type as description below:

Example 1:

Select Maximum Size: 1000 Kbytes (default setting) as the above figure. If the file size over 1000 Kbytes, the system will rename the original name (for example: TEST.TXT) as TEST-1.TXT and create another file name as TEST.TXT for logging.

Example 2:

Select Maximum Rows: 100 and check “save the new files when achieve the row”

If the file rows exceed 100, the system will rename the original name (for example: TEST.TXT) as TEST-1.TXT and create another file name as TEST.TXT for logging.

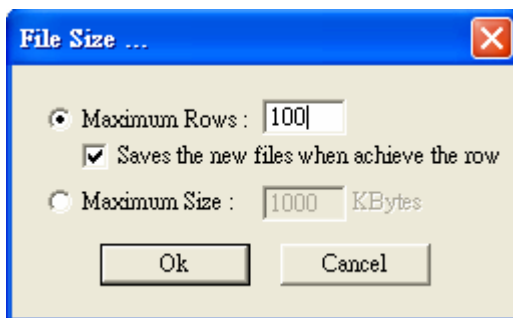

Example 3:

Select Maximum Rows: 100 and without checking “Save the new files when achieve the row”

If the file rows exceed 100, the system will log the new message in the first row and delete the row of 101.

MarkingMate

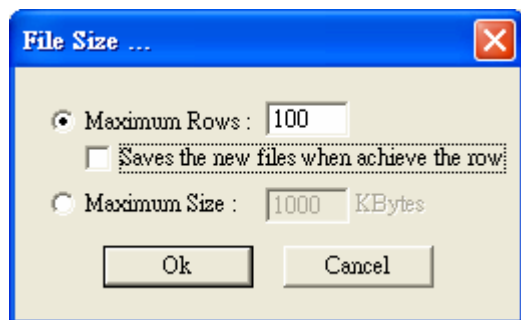

Example 4:

Select Maximum Size: 0 Kbytes or Maximum Rows: 0

The system will not change the file during recording.

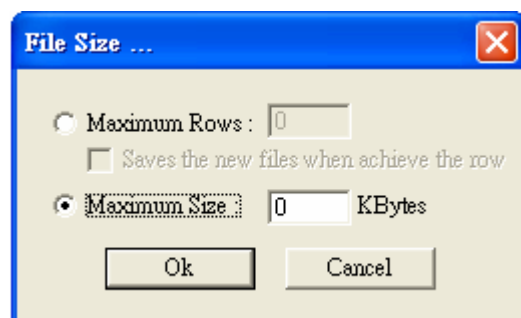

4.1.7 Import

This allows you to import a file that was not originally created by MarkingMate. It will automatically convert the file into a mark format. If the import object is a group or combine object, you can use “UnGroup” or “Break” function to break the object into several individual objects.

The dialogue box of import is as below:

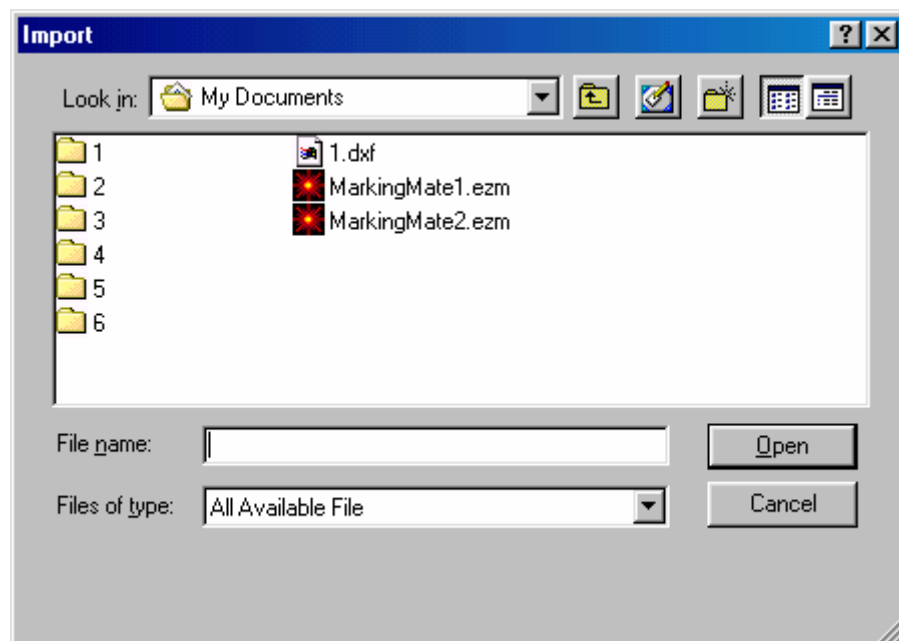

MarkingMate

Method:

Click “File” from Menu Bar and select “Import” function.

Click the  button from the Toolbar

Press the [CTRL+I] key from keyboard.

Select the following items:

Look in: Select the directory you want to import from.

File name: type or select the file name to import.

Files of type: MarkingMate allows you to import various file types such as: .EZM, .BMP, .EMF, .PNG, .PCX, .DXF, .CMP, .FPX, .PLT, .CAL, .ICO, .JPG, .PS, .EPS, .CLP, .WMF, .TIF, .CUR, .PSD, .TGA.

4.1.8 Export DXF

This allows you to transfer the current document into .dxf file format for AutoCAD or similar applications.

Click “File” from Menu Bar and select “Export DXF” function, a dialogue box as below appeared.

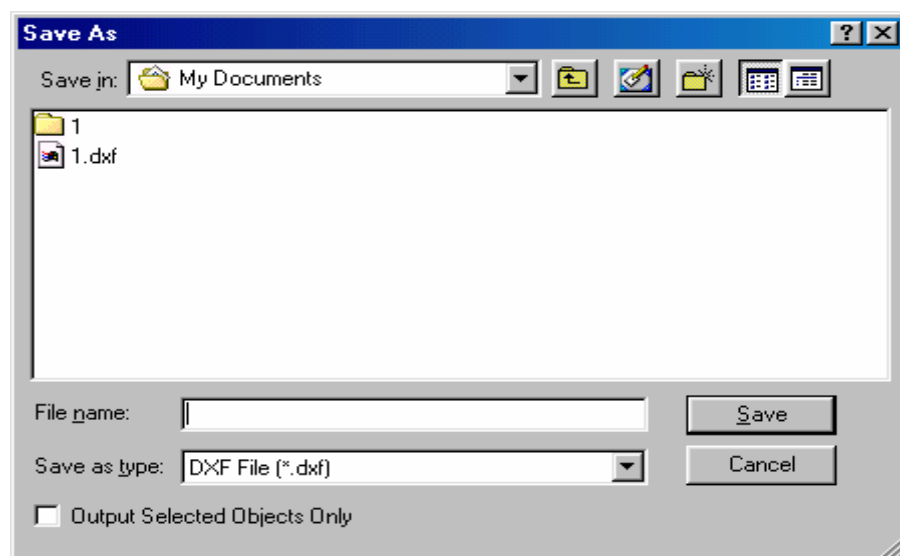

This dialogue box allows you to input:

File Name: Input file name or select from the list.

Save as type: DXF File (*.dxf)

Output Selected Objects only: You can choose to output the selected object only or not.

4.1.9 Select TWAIN Device

Select a supported scanner as below:

MarkingMate

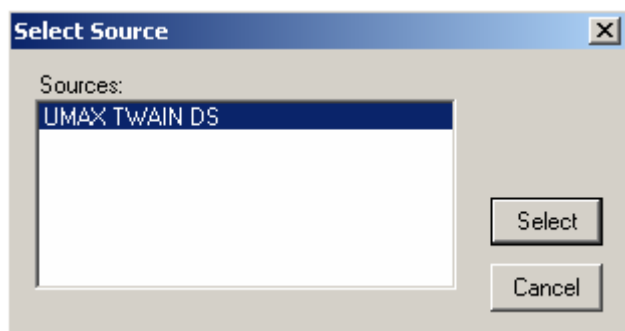

4.1.10 TWAIN Acquire

Use this function to setup image size, resolution, and etc. as below:

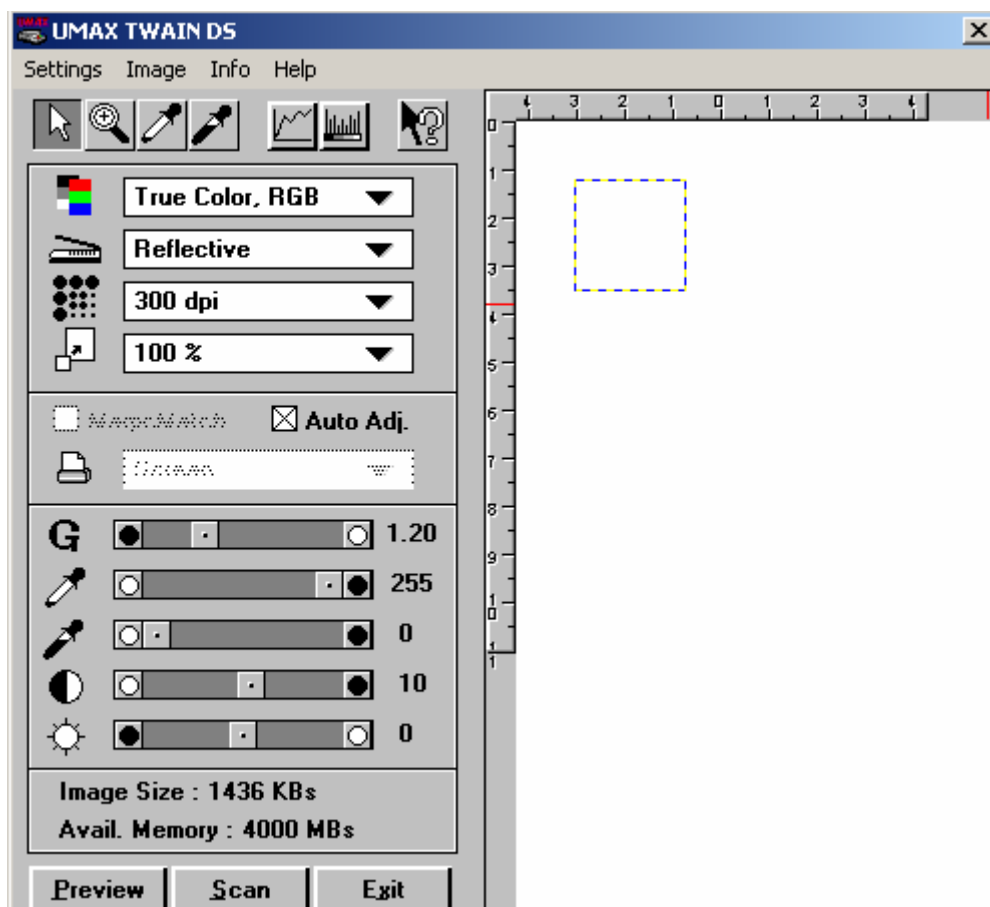

4.1.11 Config Import/Export

Import

Use this function to read the existed configuration files:

Method:

1. Select "File" from Menu Bar and click "Config Import/Export" and select "Import" will see as below:

MarkingMate

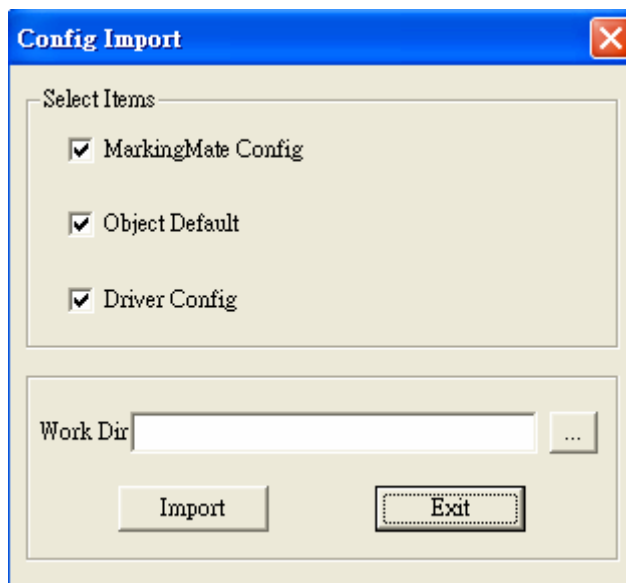

2. Select the items and directory of the existed configuration files.
3. Click "Import" button, restart the program, and the import configuration will be done.

Export

The function allows you to backup the existed configuration files:

Method:

1. Select "File" from Menu Bar and click "Config Import/Export" and select "Export" will see as below:
2. Select the items you want, input the file name and select the directory for the configuration files.
3. Click "Export" button, and the export configuration will be done.



MarkingMate

4.1.12 Print

Print the current document. This function will allow you to:

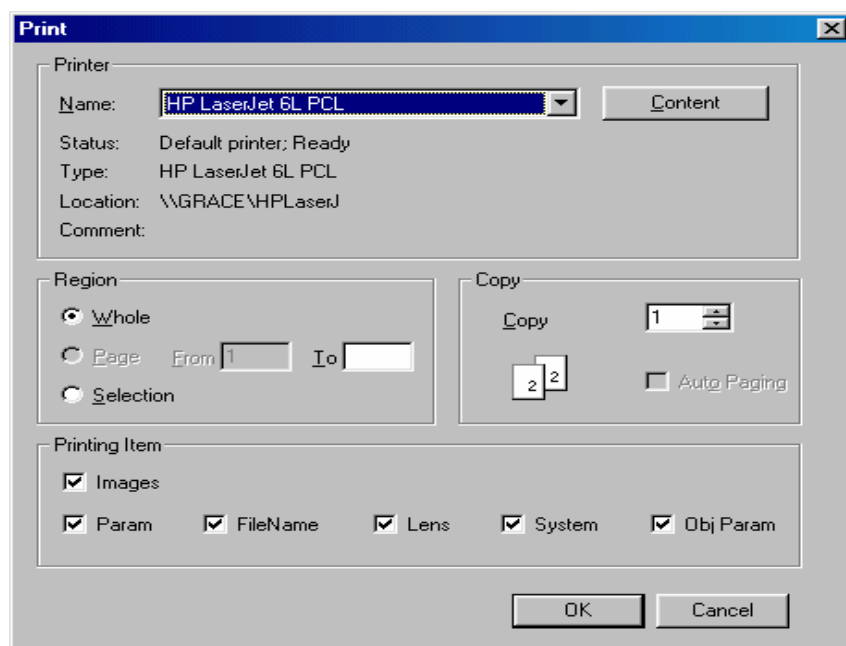

Name	Select the printer
Region	Select the region you want to print
Whole	Print all of the data in the work area
Selection	Print only the selected data
Copy	Select the number of copies you want to print
Auto Paging	Automatically adjust the document or selected data to fit the selected paper size.
Printing Item	Select the items you want to print (image, parameter, file name, lens, system, or object parameter)

If you need more detail printer setting, please go to the printer setting in the file menu.

Method:

Click "File" from Menu Bar and select "Print" function.

Press the [CTRL+P] key from keyboard.

4.1.13 Preview

Preview the current document before printing



Print – Go directly to the Print menu and begin printing

Zoom In – Magnify the current image to get a close up view

Zoom Out – Get a border view of the current image

MarkingMate

Images, Param, File Name, Lens, System, Obj Param – When the check box is selected, its setting page will be displayed while start printing.

Close – Return to the edit menu

4.1.14 Printer setting

Select the printer and edit the default printer and paper parameters.

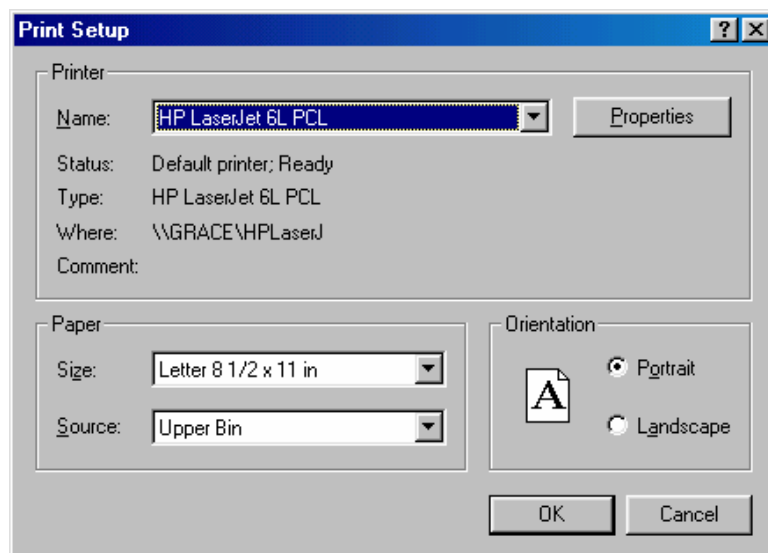

Printer

Select the printer

Paper

Select the paper source

Direction

Select horizontal or vertical print

Content

Detail printer setting

4.1.15 Exit

Exit the MarkingMate system.

Method:

Click "File" from Menu Bar and select "Exit" function.

Click the top-right button as below to close the system.



Click the top-left icon  as below to exit the system.



Press the [ALT+F4] key from keyboard.

MarkingMate

4.2 Edit Menu

“Edit” menu offers the following functions:

Redo	Replace a cancelled action
Undo	Cancel an unwanted action
Cut	Remove selected data and store it in the clipboard for future use
Copy	Duplicate selected data and store it in the clipboard for future use
Paste	Attach data from the clipboard to the current document
Delete	Delete and remove the selected data
Combine	Combine two or more objects into one. This function will allow several objects to share the same property settings
Break	Do the inversion of Combine function
Group	Combine two or more objects into one. This function will allow several objects to move together while allowing their individual property settings to remain intact
UnGroup	Do the inversion of Group function
Sort	Sort the connected parts of the selected object
Mirror Horz	Invert an image on its horizontal axis. Left will become right and vice-versa
Mirror Vert	Invert an image on its vertical axis. Up will become down and vice-versa
Baseline	Align selected text along a designated path
Split	Do the inversion of baseline function
Trans-Curve	Transfer a curved line into a series of individual angled lines. Allows these single lines to be manipulated individually
Trim	Allow selected object to be moved at set increments when the direction keys are pressed
Jump Cross	Make the intersects of two figures stagger, turn into two figures without crossing
Welding	Combine two objects so that the outline remains while eliminating the overlapping lines
Contour	This function will create an outline a selected bitmap image
Transfer to Image	Allows the resolution, color quality and black and white effects to be adjusted. And transfer the selected objects to be an image
Align	Use this function to align the selected objects to the last selected object, paper edge, or paper center
Distribute	This function will adjust how the distance between a series of objects is calculated

MarkingMate

4.2.1 Redo

Replace a cancelled action. If this function was grayed means disable.

* The maximum times of “Redo” is 20.

Method:

Click “Edit” from Menu Bar and select “Redo” function.

Press the [CTRL+Y] key from keyboard.

4.2.2 Undo

Cancel an unwanted action. If this function was grayed means disable.

* The maximum times of “Undo” is 20.

Method:

Click “Edit” from Menu Bar and select “Undo” function.

Press the [CTRL+Z] key from keyboard.

4.2.3 Cut

Remove selected data and store it in the clipboard for future use. If no data or object being selected, this function is disabled.

Method:

Click “Edit” from Menu Bar and select “Cut” function.

Click the  button from the Toolbar.

Press the [CTRL+X] key from keyboard.

4.2.4 Copy

Duplicate selected data and store it in the clipboard for future use. If no data or object being selected, this function is disabled.

Method:

Click “Edit” from Menu Bar and select “Copy” function.

Click the  button from the Toolbar.

Press the [CTRL+C] key from keyboard.

4.2.5 Paste

Attach data from the clipboard to the current document. If nothing stored in clipboard, this function is disabled.

Method:

Click “Edit” from Menu Bar and select “Paste” function.

Click the  button from the Toolbar.

Press the [CTRL+V] key from keyboard.

MarkingMate

4.2.6 Delete

Delete and remove the selected data, and the data will not be stored in the clipboard.

Method:

Click “Edit” from Menu Bar and select “Delete” function.
Press the [Del] key from keyboard.

4.2.7 Combine

Combine two or more objects into one. This function will allow several objects to share the same property settings. If fill in a combined object, the overlapping of odd numbers of objects will be filled in color, while the even numbers parts will not.

Method:

Click “Edit” from Menu Bar and select “Combine” function.
Press the [CTRL+K] key from keyboard.

Example:

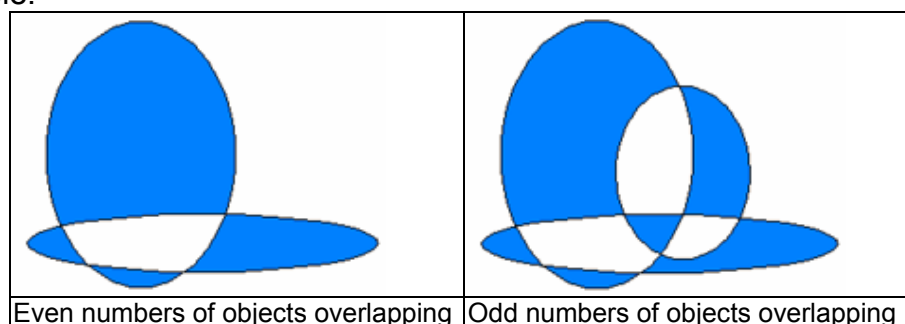

4.2.8 Break

Do the inversion of Combine function.

Method:

Click “Edit” from Menu Bar and select “Break” function.
Press the [CTRL+B] key from keyboard.

4.2.9 Group

Combine two or more objects into one. This function will allow several objects to move together while allowing their individual property settings to remain intact. This is different with “Combine” function.

Method:

Click “Edit” from Menu Bar and select “Group” function.

Click the  button from the Toolbar.

Press the [CTRL+M] key from keyboard.

MarkingMate

4.2.10 UnGroup

Do the inversion of Group function

Method:

Click “Edit” from Menu Bar and select “UnGroup” function.

Click the  button from the Toolbar.

Press the [CTRL+Q] key from keyboard.

4.2.11 Sort

Sort the connected parts of the selected object. The confuse segments as figure 1 can be sort to be as figure 2.

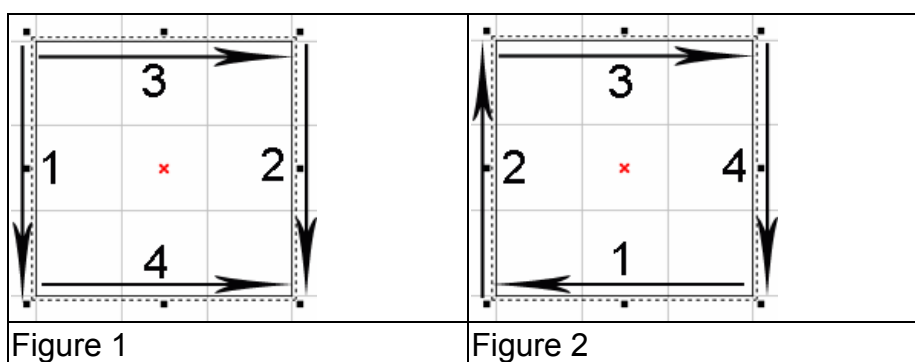

Method:

Click “Edit” from Menu Bar and select “Sort” function.

Press the [F5] key from keyboard.

4.2.12 Mirror Horizontal

Invert an image on its horizontal axis. Left will become right and vice-versa

Method:

Click “Edit” from Menu Bar and select “Mirror Horizontal” function.

Click the  button from the Toolbar.

Press the [CTRL+H] key from keyboard.

Example:

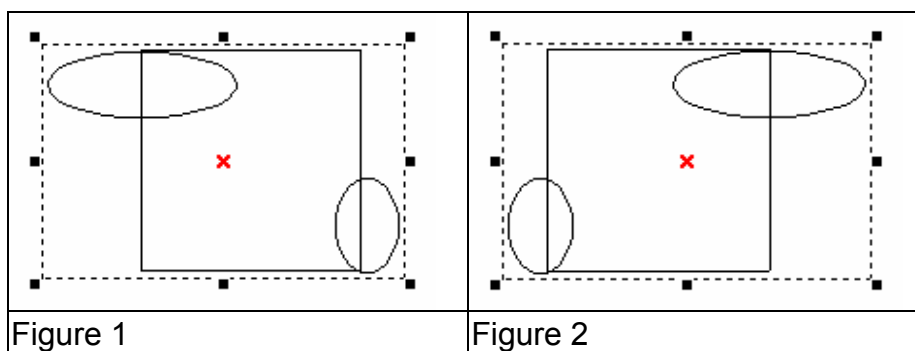

MarkingMate

4.2.13 Mirror Vertical

Invert an image on its vertical axis. Up will become down and vice-versa

Method:

Click “Edit” from Menu Bar and select “Mirror Vertical” function.

Click the  button from the Toolbar.

Press the [CTRL+L] key from keyboard.

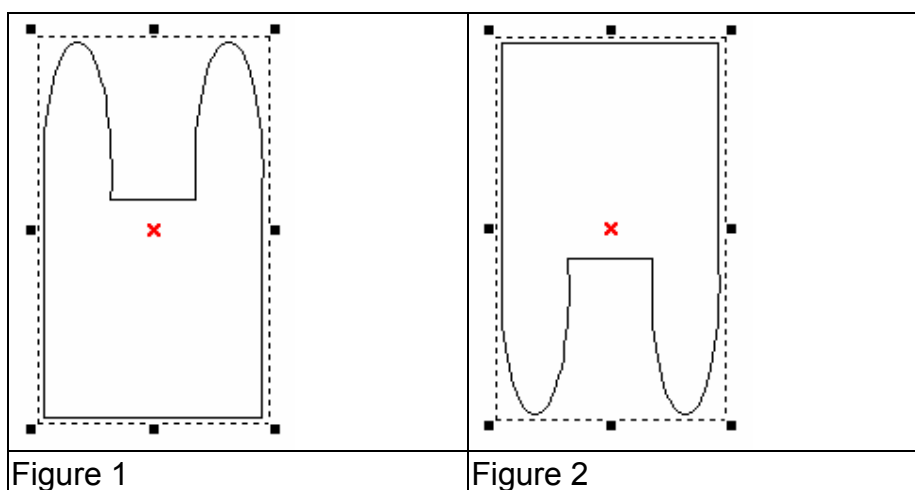

4.2.14 Baseline

Align selected text along a designated path. First select the text, then click “Edit –Baseline” from Menu Bar, the mouse pointer will become as  A, and then select the path such as line, arc, curve, or the others.

Method:

Click “Edit” from Menu Bar and select “Baseline” function.

Press the [CTRL+E] key from keyboard.

Example:

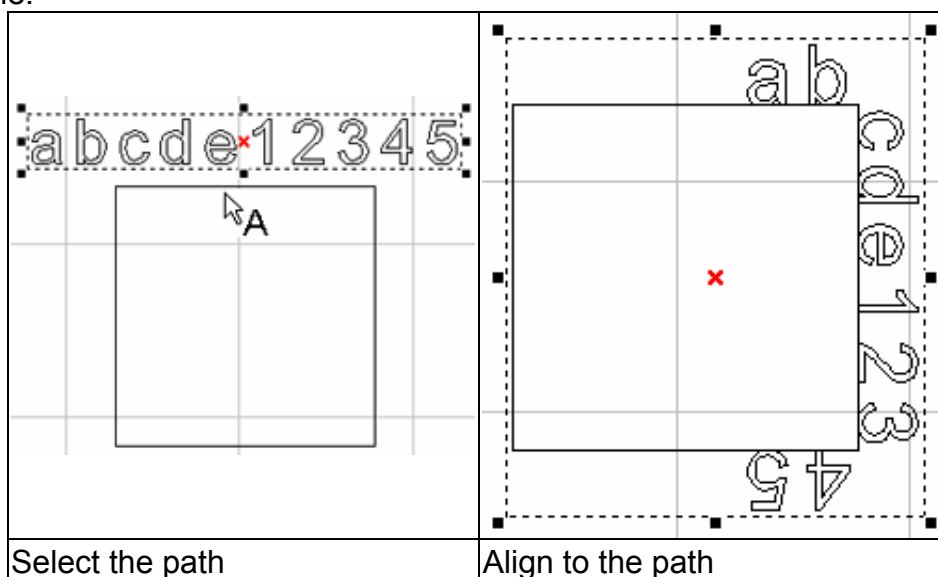

MarkingMate

4.2.15 Split

Do the inversion of baseline function

Method:

Click “Edit” from Menu Bar and select “Split” function.

Press the [CTRL+D] key from keyboard.

Example:

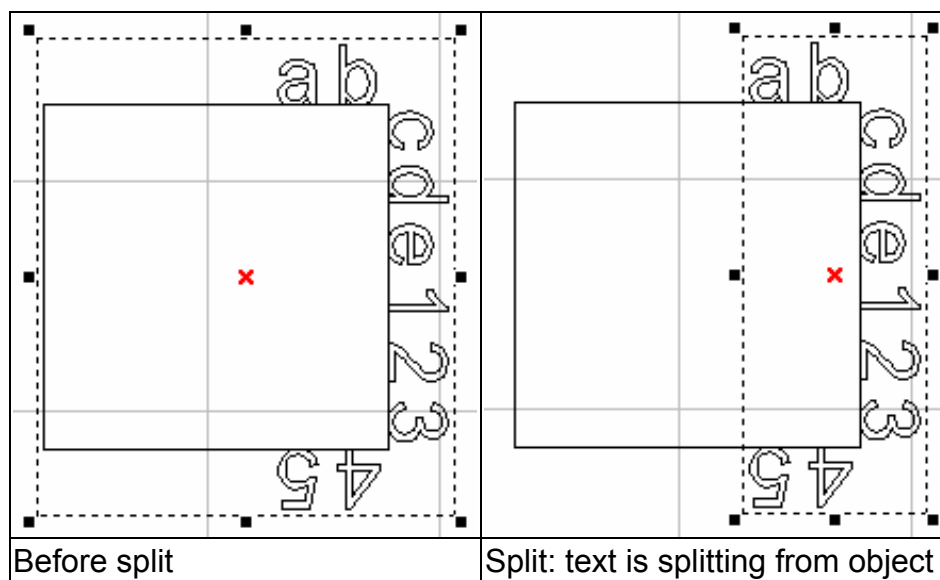

4.2.16 Trans-Curve

Transfer a curved line into a series of individual angled lines. Allows these single lines to be manipulated individually

* Only curve objects are able to use “Add Vertex” function.

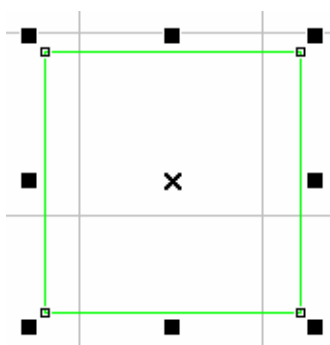

Method:

Click “Edit” from Menu Bar and select “Trans-curve” function.

Click the  button from the Toolbar.

Press the [CTRL+U] key from keyboard.

MarkingMate

4.2.17 Trim

Allow selected object to be moved at set increments when the direction keys are pressed.

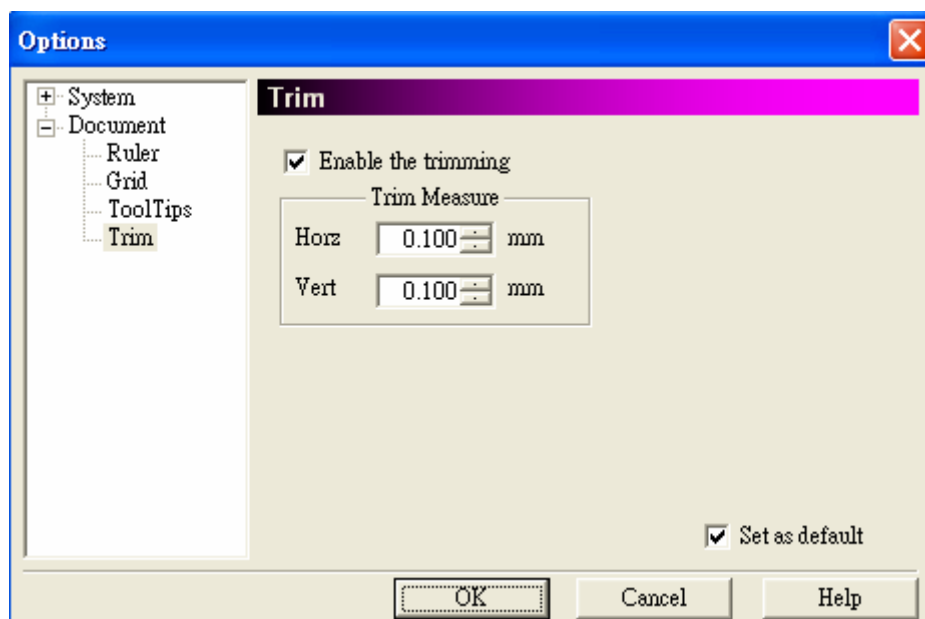

Method:

Click "Edit" from Menu Bar and select "Trim" function.
Press the [CTRL+A] key from keyboard.

4.2.18 Jump Cross

Make two figures with the line intersecting turn to be no crossing. The cross size is best to be set as between 0.008mm and 0.1mm.

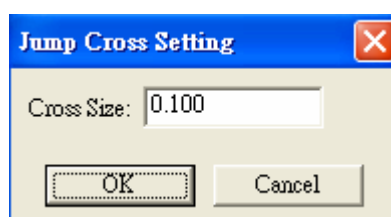

Method:

Click "Edit" from Menu Bar and select "Jump Cross" function. Enter the value of cross size in the dialogue box and click "OK" button.

Example:

MarkingMate

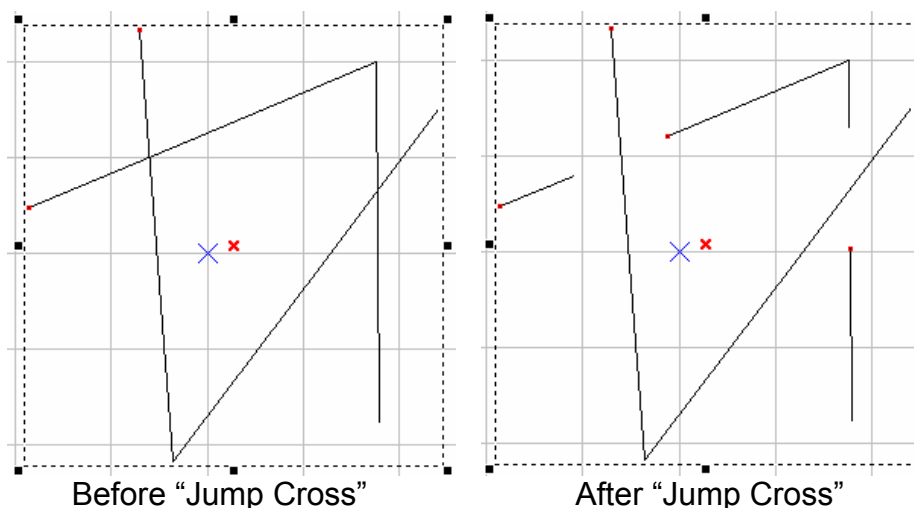

4.2.19 Welding

Combine two objects so that the outline remains while eliminating the overlapping lines.

* This function is only work for the none-text and none-image objects. If you want to do this for texts, you have to break the text into several segments first.

Method:

Click "Edit" from Menu Bar and select "Welding" function.

Click the  button from the Toolbar.

Press the [CTRL+G] key from keyboard.

Example:

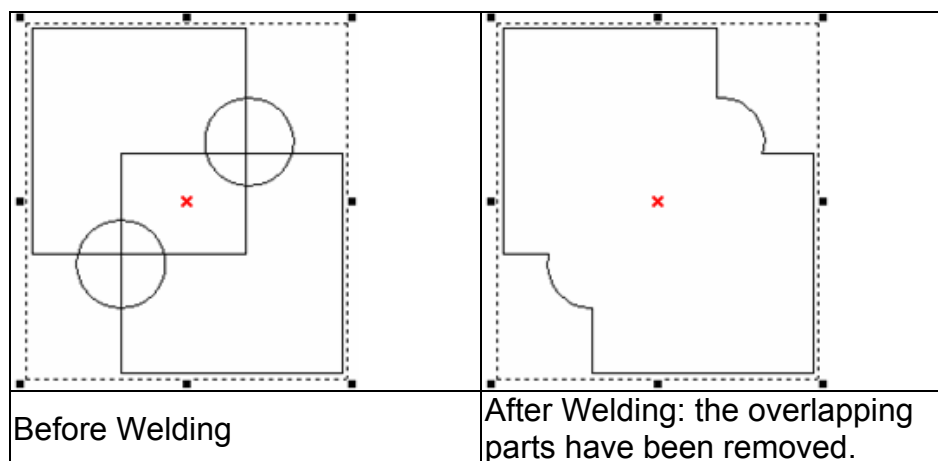

4.2.20 Contour

This function will create an outline a selected bitmap image.

MarkingMate

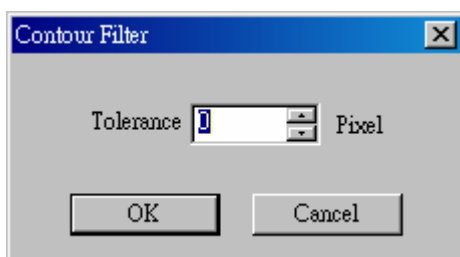

* You have to input the tolerance value (maximum is 0) to get the correct figure. After done, this image has become a normal figure. You will see a lot of segments instead of the original image, and you have to use "break" function before "contour".

Method:

Click "Edit" from Menu Bar and select "Contour" function. Press the [CTRL+W] key from keyboard.

Example:

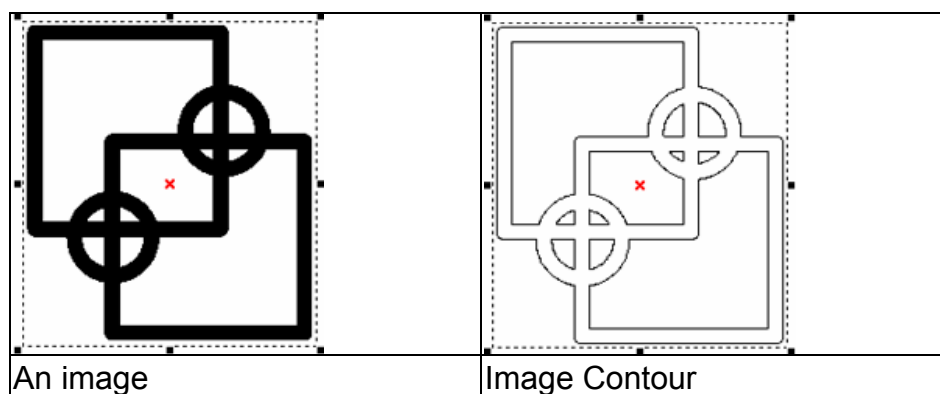

4.2.21 Transfer to Image

Allow the resolution, color quality and black and white effects to be adjusted. And transfer the selected objects to be an image. The below dialogue box can change the resolution, color, and dithering mode.

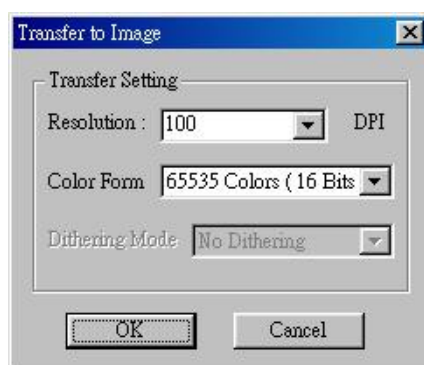

Method:

Click "Edit" from Menu Bar and select "Trans to Image" function. Press the [CTRL+T] key from keyboard.

MarkingMate

4.2.22 Align

Use this function to align the selected objects to the last selected object, paper edge, or paper center.

Left – align to the left

Middle – align to the middle

Right – align to the right

Top – align to the top

Center – align to the center

Bottom – align to the bottom

Align to:

Last Select Object – align to the last selected object

Paper Edge – align to the paper edge

Paper Center – align to the paper center

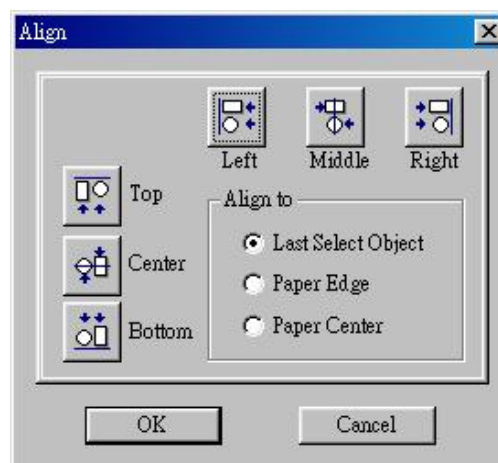

Method:

Click “Edit” from Menu Bar and select “Align” function.

Click the  button from the Toolbar.

4.2.23 Distribute

This will adjust how the distance between a series of objects is calculated.

Left – adjust the distance between the left-edge of each object

Middle – adjust the distance between the middle of each object

Distance – adjust the distance between the space of each object

Right – adjust the distance between the right-edge of each object

Top – adjust the distance between the top of each object

Center – adjust the distance between the center of each object

Distance – adjust the distance between the space of each object

Bottom – adjust the distance between the bottom of each object

Total Area - The distribute area is according to a selected area, paper area, or an adjustable border area.

Method:

Click “Edit” from Menu Bar and select “Distribute” function.

Click the  button from the Toolbar.

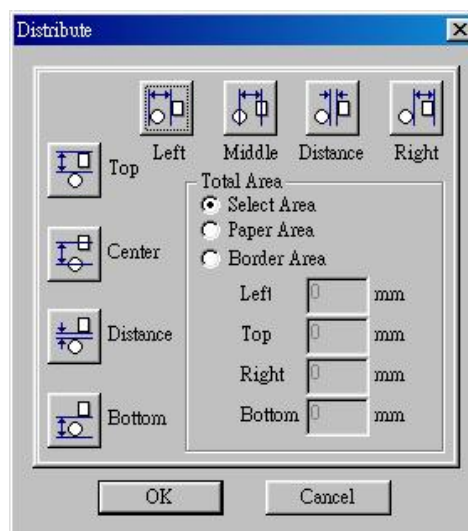

MarkingMate

4.3 Draw Menu

“Draw” menu offers the following functions:

Selection	Selects or deselects objects in the Work Area
Vertex	Creates vertexes
Line	Inserts straight lines from point-to-point-to-point
Arc	Creates arcs, circles, and spirals
Circle	Creates circles and ovals
Rectangle	Creates squares and rectangles
Curve	Creates a curve using three points of reference
Curve Brush	Draws freehand lines by the mouse
Text	Inserts text in the Work Area
Arc Text	Inserts text based on an arc
1D Barcode	Creates 1D barcode
2D Barcode	Creates 2D barcode
Control	Inserts a control object into the output sequence

MarkingMate

4.3.1 Selection

Selects or deselects objects in the Work Area

Tool Box : 

4.3.2 Line

Insert straight lines from point-to-point-to-point. Click on the line tool and click on a designated starting point in the Work Area, click on a second point and straight line will appear between the points. When you select three points two lines will appear. Press the right mouse button to stop the line tool function. If you press **C** key, the continuous line segments will become a close path and stop the line tool function.

* **Tips:** Use CTRL key to insert straight lines, the next line will move 15° to the previous line as figure 1 below

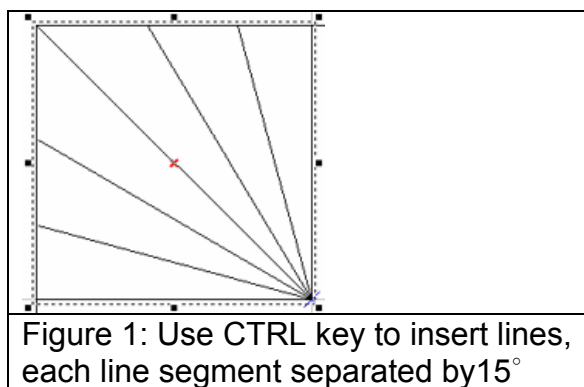

Method:

Click "Draw" from Menu Bar and select "Line" function.

Click the  button from the Toolbar.

Property Table:

Property Table - Curve

The continuous line segments can be set to a closed path.

* Transfer the object to curve before using this Property Table.

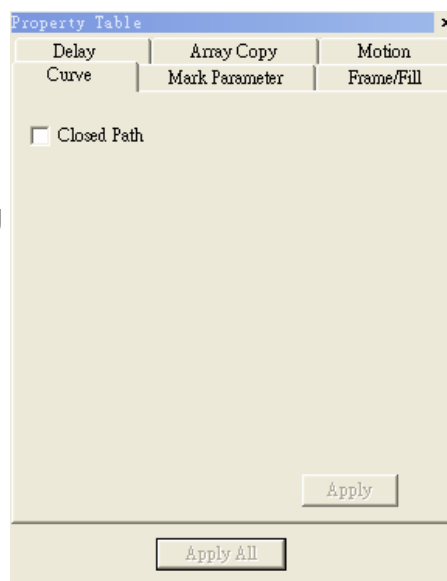

MarkingMate

4.3.3 Arc

Create arcs, circles and spirals. Click on the arc tool and select a starting point on the Work Area. Click on a second point. By moving the mouse you still see all the possible arcs that can pass through your two designated points. Press the right mouse button to stop drawing. Users can press **C key** to make the continuous arcs become a closed loop and end this function.

Method:

Click "Draw" from Menu Bar and select "Arc" function.

Click the  button from the Toolbar.

Property Table

Property Table – Arc

Adjust the center of X- and Y-axis, radius, and position of start dot and end dot.

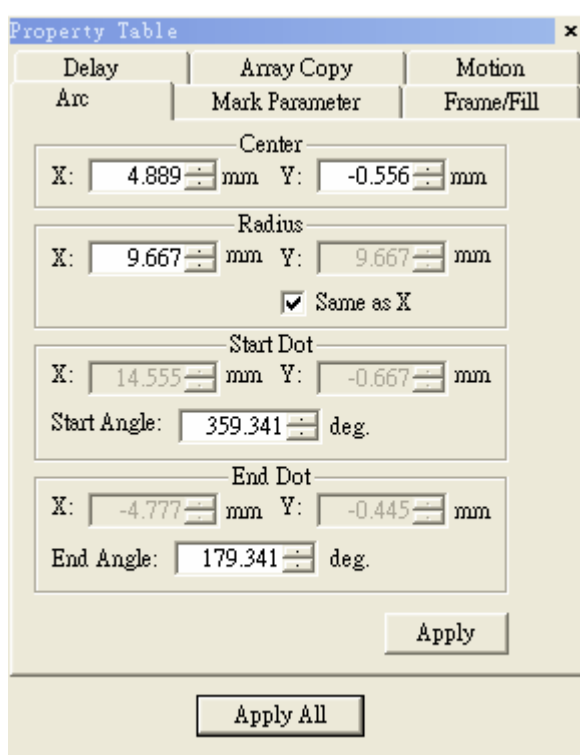

Delay	Array Copy	Motion
Arc	Mark Parameter	Frame/Fill
Center		
X: 4.889 mm	Y: -0.556 mm	
Radius		
X: 9.667 mm	Y: 9.667 mm	
<input checked="" type="checkbox"/> Same as X		
Start Dot		
X: 14.555 mm	Y: -0.667 mm	
Start Angle: 359.341 deg.		
End Dot		
X: -4.777 mm	Y: -0.445 mm	
End Angle: 179.341 deg.		
Apply		
Apply All		

4.3.4 Circle

Create circles and ovals. Click on the circle tool and select a starting point on the Work Area. Press the left mouse button and moving the mouse to the other point, a circle is finished. Press the right mouse button to stop this function.

* **Tips:** Use CTRL key on drawing a circle, the circle will become an equilateral circle as figure 1 below.

MarkingMate

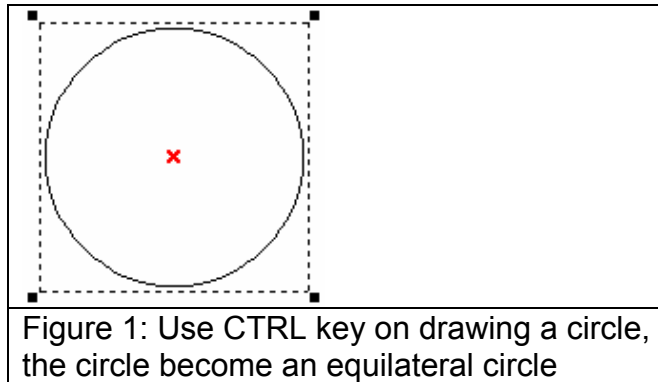

Method:

Click “Draw” from Menu Bar and select “Circle” function.

Click the  button from the Toolbar.

Marking Way:

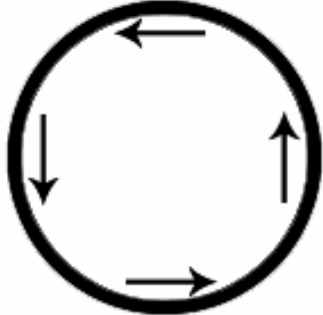
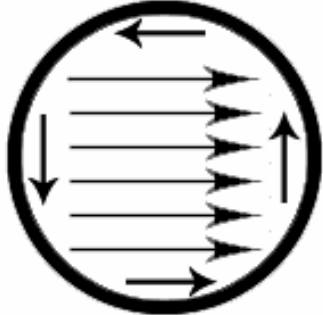
No Fill	Fill
Marking starting from 0 degree in counterclockwise direction.	Marking starting from left to right and then the external frame.
	

Property Table:

MarkingMate

Property Table - Circle

Adjust the center and radius of the circle.

Mark on “Same as X Radius”, the circle will become a equilateral circle.

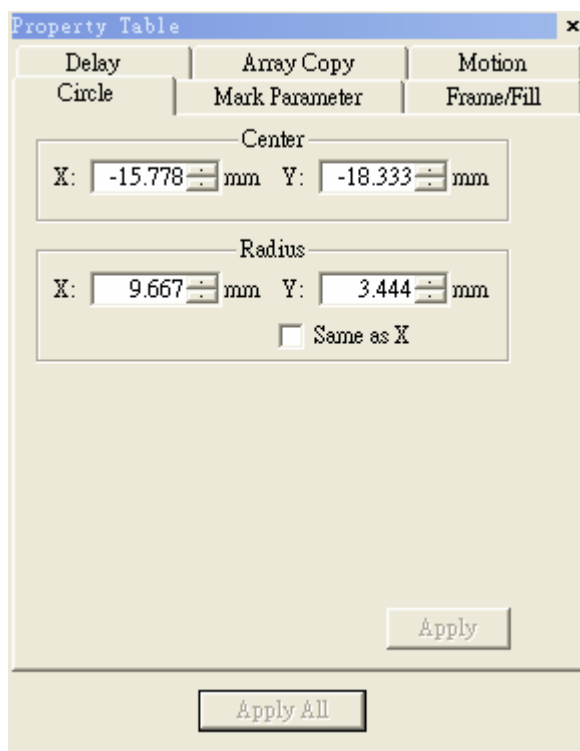

4.3.5 Rectangle

Create squares and rectangles. Click on the circle tool and select a starting point on the Work Area. Press the left mouse button and moving the mouse to the other point, a rectangle is finished. Press the right mouse button to stop this function.

Method:

Click “Draw” from Menu Bar and select “Rectangle” function.

Click the  button from the Toolbar.

Marking Way:

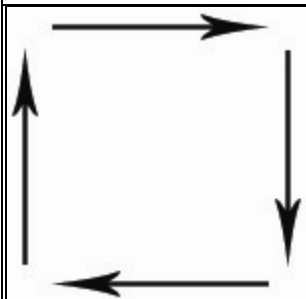
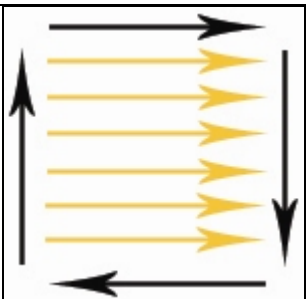
No Fill	Fill
Marking starting from the upper left corner	Marking starting from left to right and then the external frame.
	

Property Table:

MarkingMate

Property Table - Rectangle

Adjust the radius of the rectangle.

* The shape may be different depend on the default value**.

****Default** – means the object without any modification.

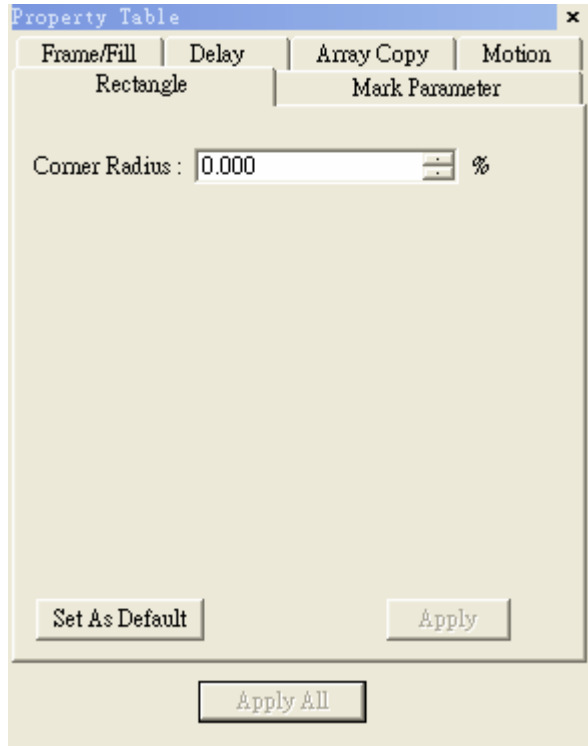

4.3.6 Curve

Create a curve using three points of reference. Click on the curve tool and select a starting point on the Work Area. Click on a second point to designate the center point of the curve. Click on a third point to complete the curve. Each future click will continue the curve to a new point. Press the right mouse button to stop drawing. If users press **C key**, the curve will become a closed path and stop the function.

Method:

Click "Draw" from Menu Bar and select "Curve" function.

Click the  button from the Toolbar.

Property Table

Curve: The continuous curve can be set to a closed path.

4.3.7 Curve Brush

Create a curve by moving mouse. Click on the curve brush tool and select a start point on the Work Area. Press the left mouse button, moving the mouse until let go the mouse will stop the curve. Press the right mouse button to end this function.

Method:

Click "Draw" from Menu Bar and select "Curve Brush" function.

Click the  button from the Toolbar.

Property Table:

Curve Brush: the continuous curve can be set to a closed path.

MarkingMate

4.3.8 Text

Insert text in the Work Area. Enter the text you want then click OK. Click on a selected point in the Work Area to insert the text. After the text is inserted, you can edit the text properties in the Property Table.

Method:

Click “Draw” from Menu Bar and select “Text” function.

Click the  button from the Toolbar.

Marking Way:

If a text object contains a batch of characters, the laser will mark by characters at one time. If you need to mark the whole text at one time, then you have to transfer the object to be a curve object.

Property Table:

Property Table - Text

This page will allow you to select font and style, set font size and oblique angle.

Checked the “**Enable Jump Cross**” checkbox can make two figures with the line intersecting turn to be no crossing. (please refer to **4.2.18 Jump Cross**)

Checked the “**Auto Text**” checkbox, the text will be changed to be an auto text object. (Please refer to section **2.5.2.1 Auto Text Setting**)

Checked “**Advanced**” button to do more detail setting of the text (as below).

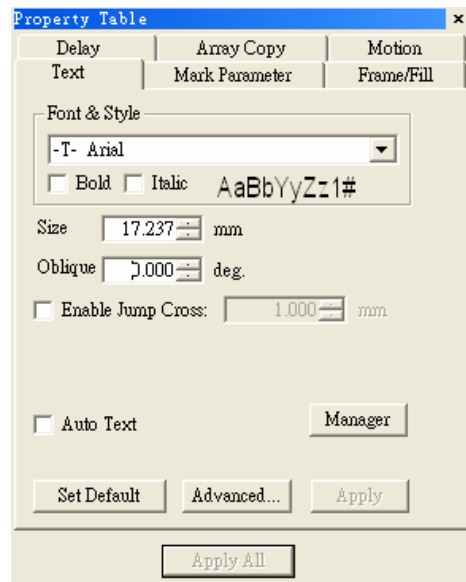

Text Advanced setting

Text pitch

Spacing between characters

Line pitch

Spacing between lines

Arrange

Horizontal or Vertical

Alignment

Alignment direction

Text Welding:

Add “Welding” function to the overlapping part of the text.

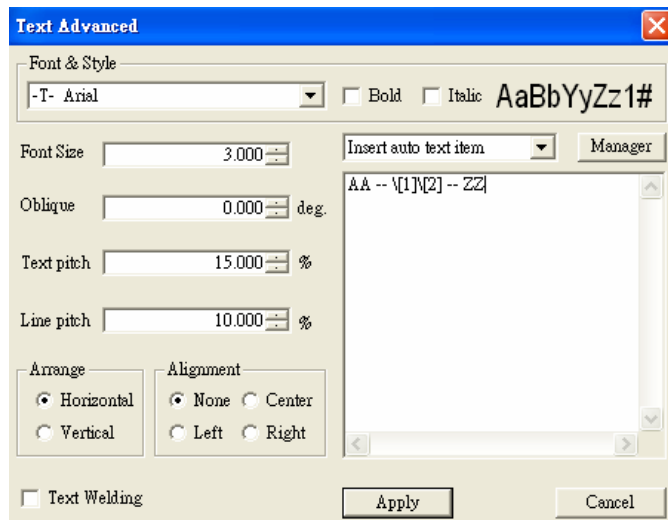

MarkingMate

For example: the Chinese word as below with overlapping can be fixed by adding this function.

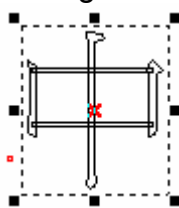

Without “Text Welding”

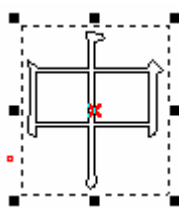

With “Text Welding”

Insert Auto Text Item: If there are more than one Auto Text objects, then add the text content on the blank area. (For more detail descriptions please refer to the **2.5.2.2 Multi Auto Text Setting.**)

Enable or disable the Text Bar

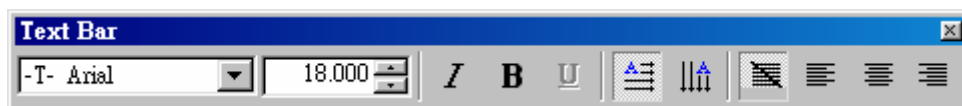

Font		Select font
Size		Adjust font size
Italic		<i>Adjust text in italic</i>
Boldface		Adjust text in boldface
Underline		<u>Add underline to text</u>
Horizontal Text		Horizontal text
Vertical Text		Vertical text
None alignment		None alignment
Left alignment		Left alignment
Center alignment		Center alignment
Right alignment		Right alignment

4.3.9 Arc Text

Insert text based on an arc in the Work Area. Enter the text you want then click OK. Click on two selected points in the Work Area to insert the text. After the text is inserted, you can edit the arc text properties using the editing functions of the Property Table.

MarkingMate

Method:

Click “Draw” from Menu Bar and select “Arc Text” function.

Click the  button from the Toolbar.

Property Table:

Property Table – Arc Text

Center : set center position

Radius : set radius scale

Show Arc : show the path of arc text

Same as X Radius : make it as a equilateral circle

Text Position : text position on the path

Horz. Offset : offset value of text

Baseline Offset : spacing between text and baseline

Close-to-Baseline : text facing baseline

Reverse : reverse text

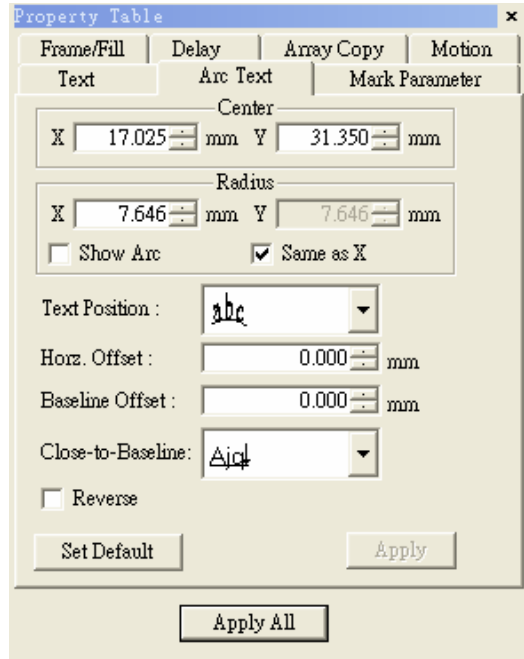

4.3.10 1D Barcode

Select the 1D Barcode Tool from Tool Box or the Draw Menu. A dialog box will open for user to enter the data. When all of the barcode information is entered, select OK. Click on an insertion point to place the barcode in the Work Area. All barcode properties can be edited later using the Property Table.

Method:

Click “Draw” from Menu Bar and select “1D Barcode” function.

Click the  button from the Toolbar.

Property Table

Code Type: Code 39 、 Code 128 、 Code 93 、 Code Bar 、 ITF 、 MSI Code 、 Us PosNet 、 UPC-A 、 UPC-E 、 EAN 8 、 EAN 13 、 UCC 128 、 EAN 128 、 FIM 。

Show Text: Checked the box, the text content will be displayed under the barcode.

Invert: When the background is black, you need to use this function.

EX: The barcode reader is not easy to read the barcode marked on black work piece, use invert function will make it more readable.

Auto Text: The barcode data will be changed as an auto text.

Check Digit: A check digit is calculated automatically and added.

A: The distance between laser spot center and the edge of barcode.

MarkingMate

B: The space between the next two laser spots

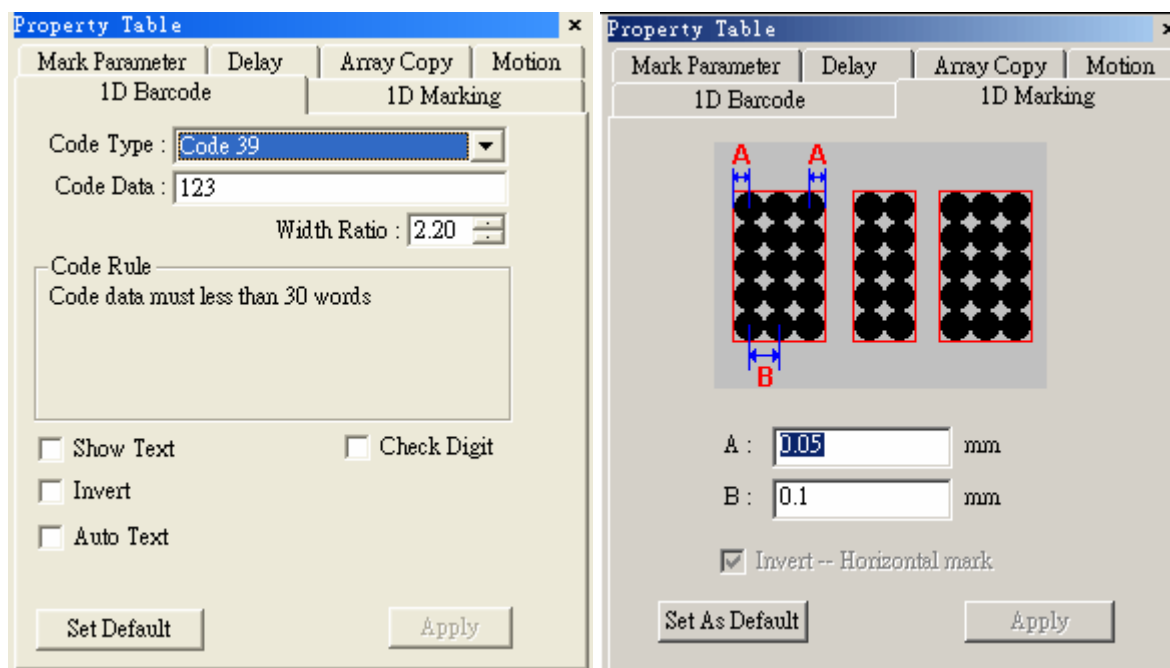

4.3.11 2D Barcode

Select the 2D Barcode Tool from the Tool Box or the Draw Menu. A dialog box will appear for user to enter the data. When all of the barcode information is entered, select OK. Click on an insertion point to place the barcode in the Work Area. All barcode properties can be edited later using the Property Table.

Method:

Click "Draw" from Menu Bar and select "2D Barcode" function.

Click the  button from the Toolbar.



Property Table:

2D Barcode Type

ECC 000~140, ECC 200, PDF417, QR Code, and Maxi Code

Style

The barcode is divided into many cells, each cell has three style options as below:

Spot The spot can not be overlapped	Line Mark as lines	Rectangle From outside to inside marked as rectangles
		

Spot Size

Size of laser spot

MarkingMate

Spot Delay



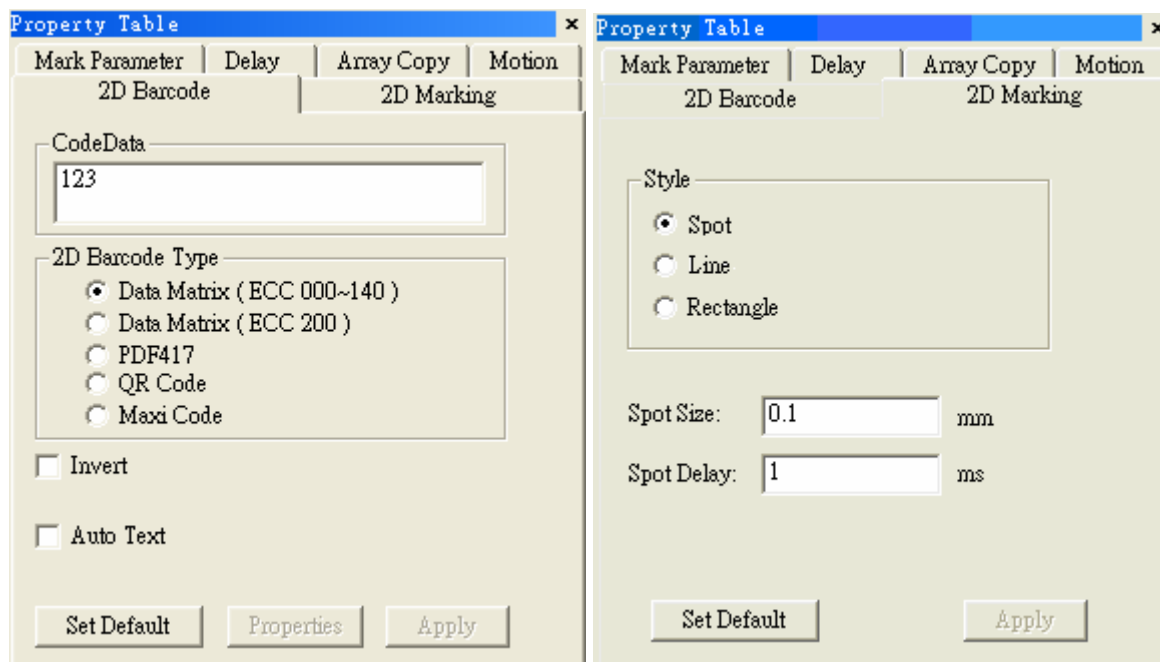



The longer the spot delay, the mark effect will be stronger



4.3.12 Control

Select the Objview bar from the View Menu will activate the Object Browser. It will appear on the left side of the screen. The object order is shown in the Object Browser will also be the output sequence during marking. The numbers in parentheses indicates the order in which the different objects were created.

Select Control from the Draw Menu can insert a control object into the output sequence. There are eight Control objects include

Digital_In , Digital_Out ,
 Delay_Time , Do_Pause ,
 Move To , Reset , Loop ,
 and Ring .

Digital_In

To adjust the information contained in each incoming pulse selects "Digital In" in the Object Browser. Using the right mouse button, click on Property Table. The Property Table should reveal the eight-input positions that can be modified.

SET: high potential

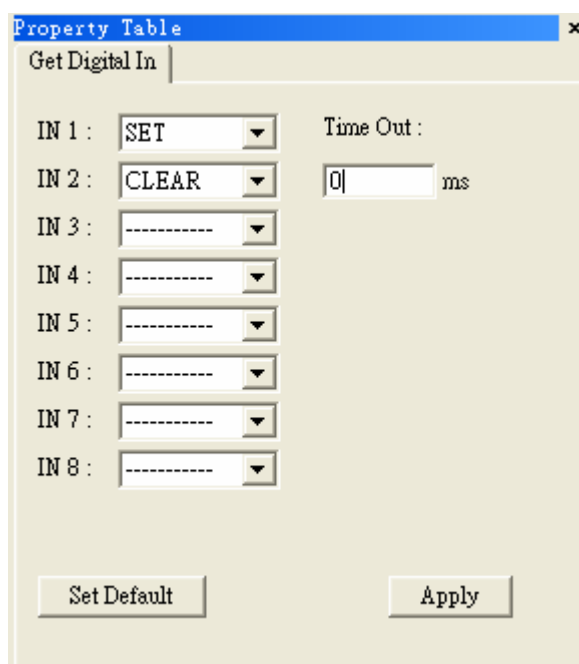

MarkingMate

CLEAR: low potential

-----: ignore

Time Out: the waiting time

If set the Time Out as 10ms, that means if no signal inputs within 10ms, then mark the next object.

Digital_Out

Digital_Out tells your computer to wait for a signal response. To adjust the information contained in each outgoing pulse selects “Digital Out” in the Object Browser. Using the right mouse button, click on Property Table. The Property Table should reveal the eight-input positions that can be modified.

SET: high potential

CLEAR: low potential

-----: ignore

Clear Signal: if checked this box, you may input a value in the **Waiting Time** box, the system will clear all signals after exceeding the waiting time.

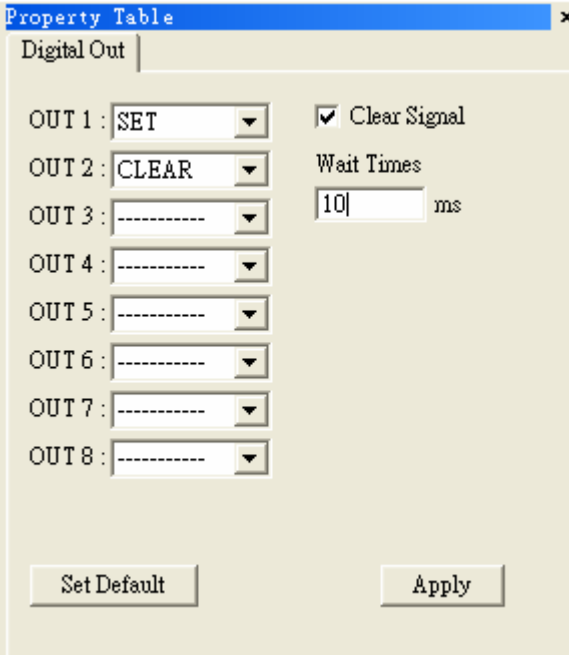

OUT	Signal	Clear Signal	Wait Times
OUT 1	SET	<input checked="" type="checkbox"/>	
OUT 2	CLEAR	<input type="checkbox"/>	
OUT 3	-----	<input type="checkbox"/>	10 ms
OUT 4	-----	<input type="checkbox"/>	
OUT 5	-----	<input type="checkbox"/>	
OUT 6	-----	<input type="checkbox"/>	
OUT 7	-----	<input type="checkbox"/>	
OUT 8	-----	<input type="checkbox"/>	

Delay_Time

Delay_Time allows you to insert a delay into the marking sequence. You can adjust the duration of the delay by using the right mouse button to click on Delay Time in the Object Browser. Use this to display the Property Table. The Property Table will allow you to increase the delay time.

For example: if there is a rectangle, a delay time of 10ms, and a curve object in a layer, then the system will first mark the rectangle, wait 10ms, and then mark the curve object.

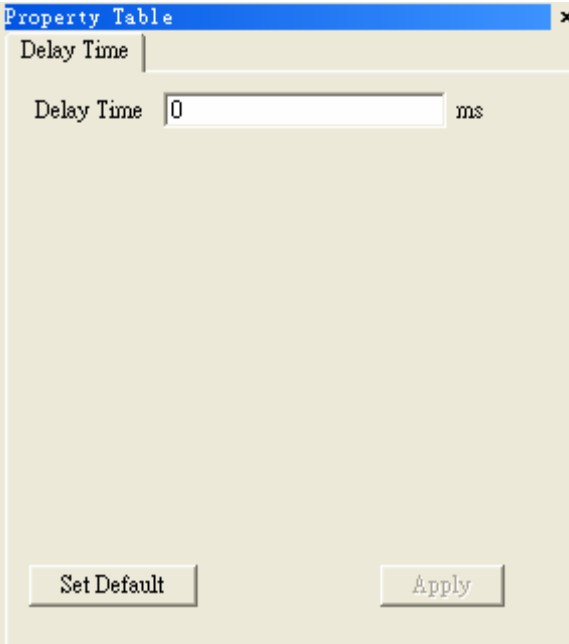

Delay Time
0 ms

MarkingMate

Do_Pause

Do_Pause is to insert a pause into the marking sequence. When the marking sequence reaches this step, the system will stop and wait for next marking progress.

Move To

Move To is a special part of Rotary Axis. When the marking sequence reaches this step, the system will move the object to an angle you want.

Relative

If check the box, the position will be considered as a relative position, otherwise, it is considered as an absolute position.

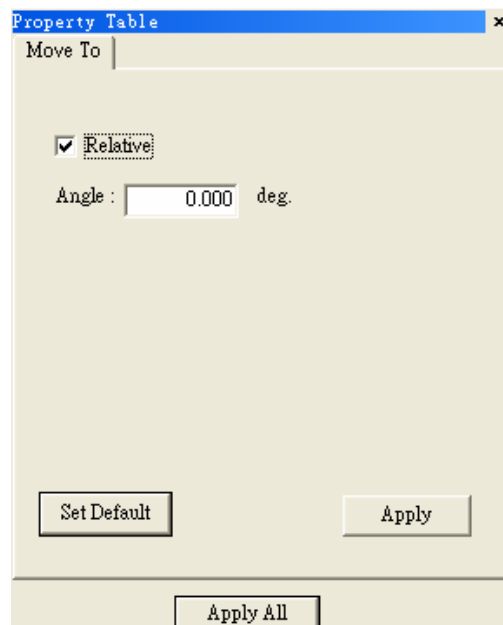

Reset

Reset can clear the settings.

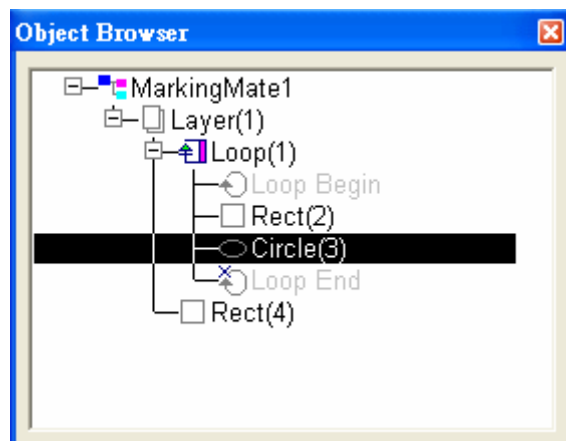

Loop

When click the Loop button, you will see two sub-objects (a Loop Begin and a Loop End) in the Object Browser. Simply use the mouse to move the objects to the place between Loop Begin and Loop End, and then these objects will be marked repeatedly (see the right figure).

The repeat time is set in the Property Table as below:

Total Number: the repeat times

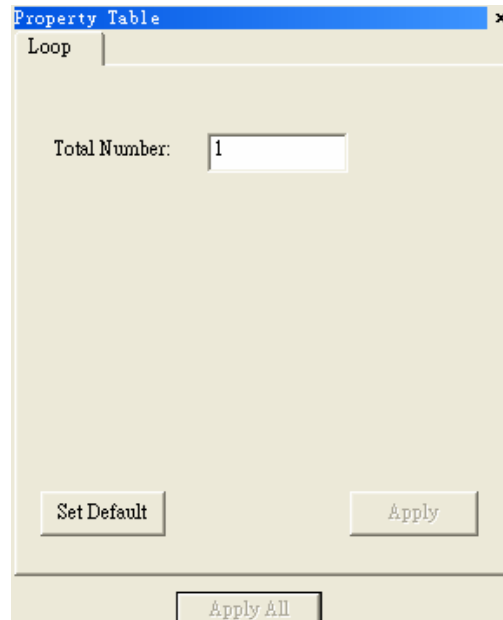

MarkingMate

Ring

Ring object is an optional function which must be used with rotary axis.

When click the “Ring” button, you will see a Ring object in Object Browser, and its parameters can be set in Property Table.

If there is a Ring object in the marking sequence, the Galvo motor will first move the right position of X and Y, and then laser on, and rotary axis rotate the right angle as we set, and then laser off.

For the setting as right figure, the laser will mark a ring finally.

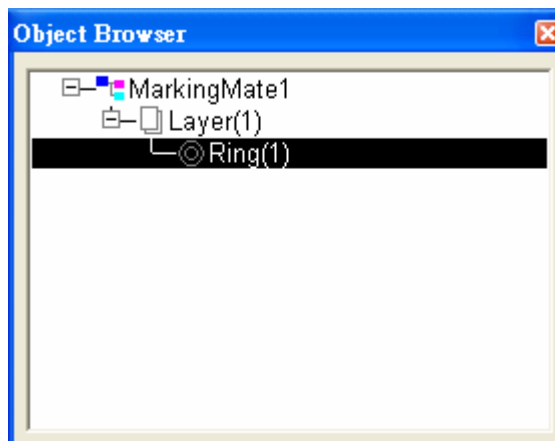
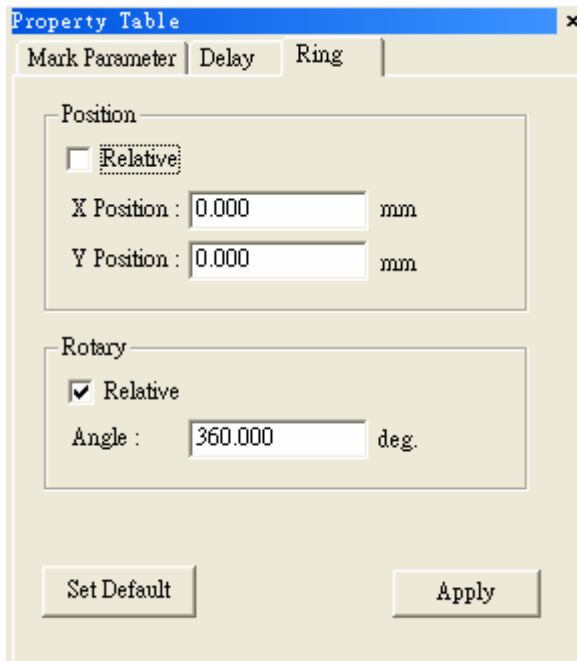

MarkingMate

4.4 Image Menu

“Image” menu offers the following functions:

Effects	Modify the image effects Posterize Mosaic Average Median Sharpen Add Noise Emboss Edge Enhance Oilify
Spatial Filters	Use different filters Gradient Laplacian Sobel Prewitt Shift & Difference Line Segment

MarkingMate

4.4.1 Effects

4.4.1.1 Posterize

Click "Image – Effects - Posterize"

This effect will expand or limit the amount of colors on the spectrum that is made available to the selected image. If you choose 2 levels per color plane there will be two shades of red available to the image. If you choose 64 levels per color plane then the image will have more detailed color.

The original image:



When choose 2 levels per color plane:

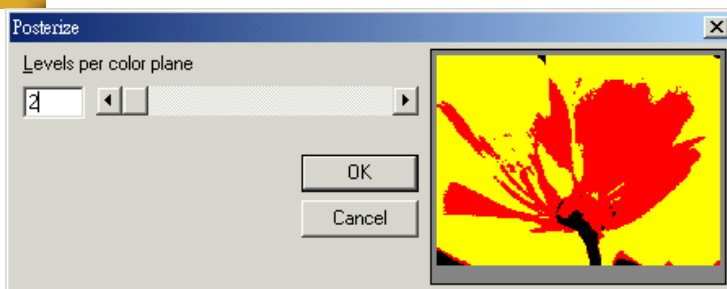

When choose 20 levels per color plane:

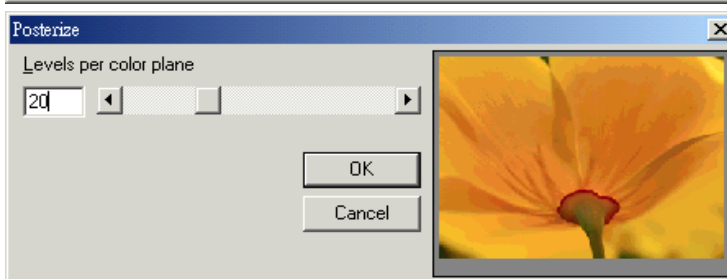

When choose 64 levels per color plane:

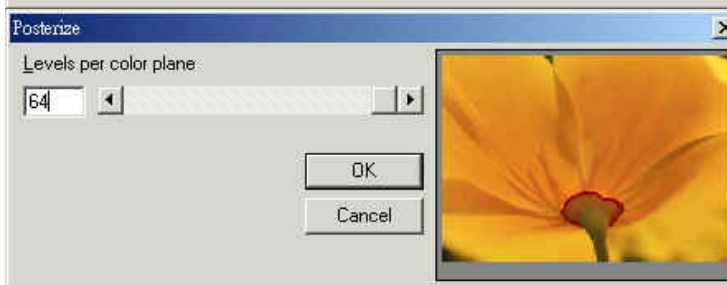

4.4.1.2 Mosaic

Click "Image – Effects - Mosaic"

This effect will increase the size of the pixels in the graphic image. The tile size of 4 will magnify each pixel by four creating a blurred effect.

MarkingMate

The original image:



When the tile size is 2:

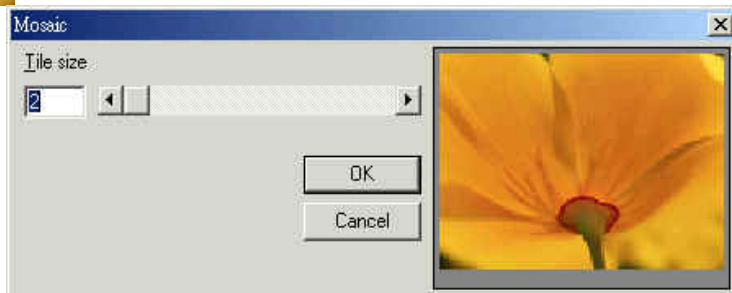

When the tile size is 20:

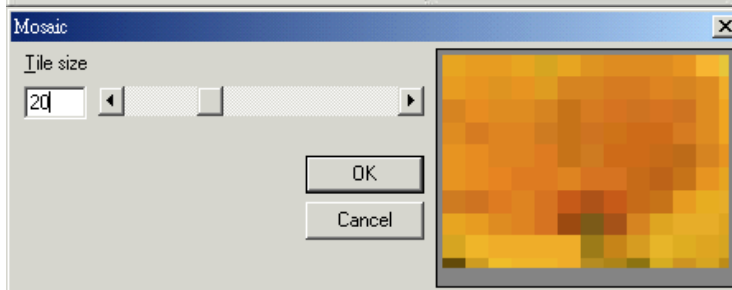

When the tile size is 64:

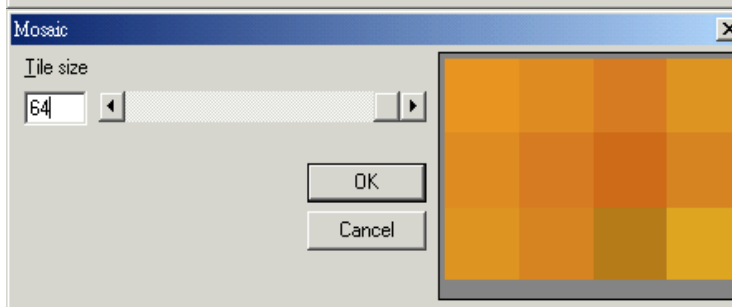

4.4.1.3 Average

Click "Image – Effects - Average"

Each pixel is affected by the average property within a 3x3 to 11x11 area.
Create a blurred effect.

The original image:



MarkingMate

When the sample size is 3:

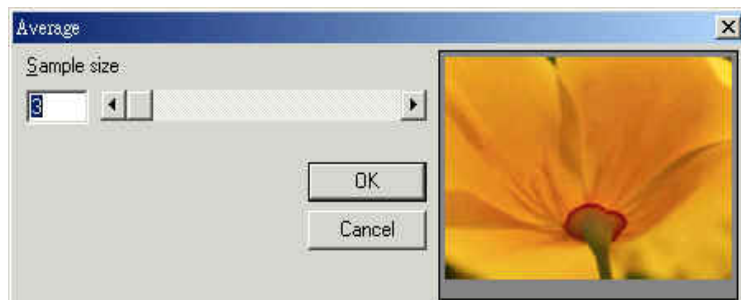

When the sample size is 7:



When the sample size is 11:

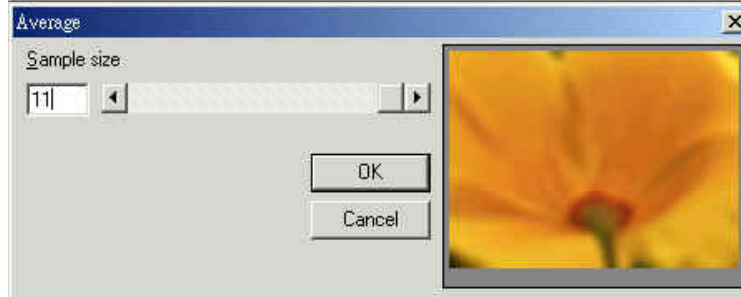

4.4.1.4 Median

Click "Image – Effects - Median"

Create a "median effect" in a 3x3 to 11x11 area. Image becomes "claylike."



When the sample size is 3:

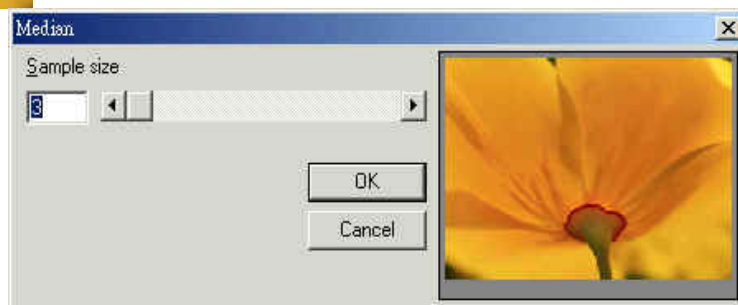

MarkingMate

When the sample size is 7:



When the sample size is 11:

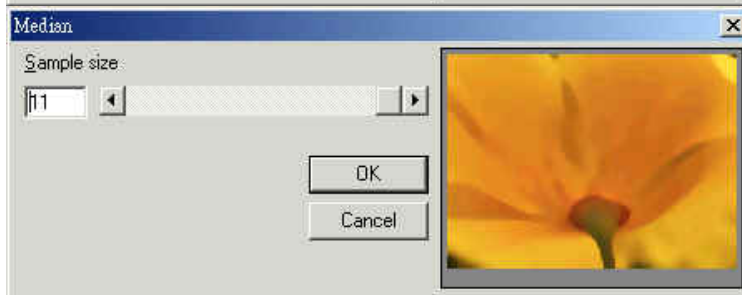

4.4.1.5 Sharpen

Click "Image – Effects - Sharpen"

Resolution increased, contrast is emphasized. Increase to +100% for maximum contrast or decrease to -100% for a blurring effect.

The original image:



When sharpen percentage is 0:



When sharpen percentage is -100:

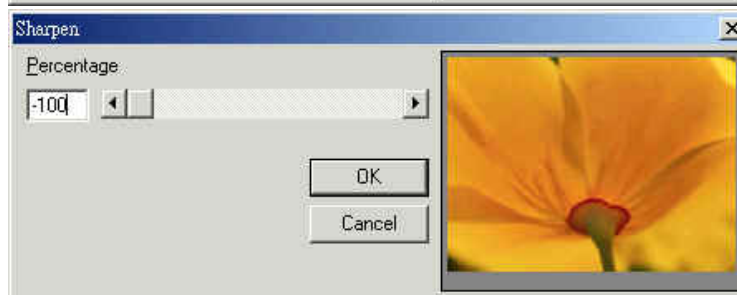

MarkingMate

When sharpen percentage is 100:

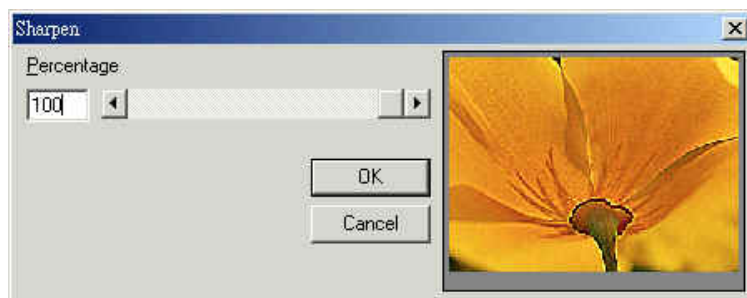

4.4.1.6 Add Noise

Click "Image – Effects – Add Noise"

Add Red, Green or Blue "snow" to the image.
The original image:



When 25 level noise is added:

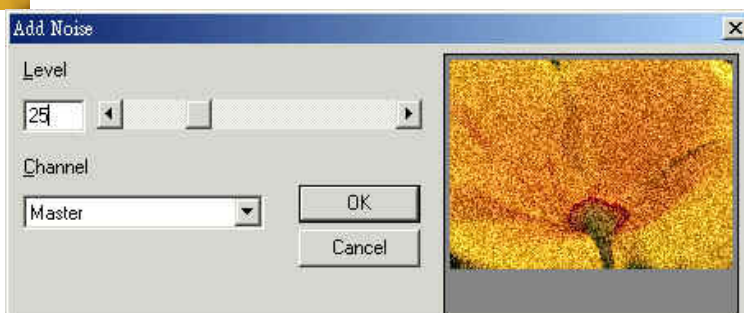

When 50 level noise is added:

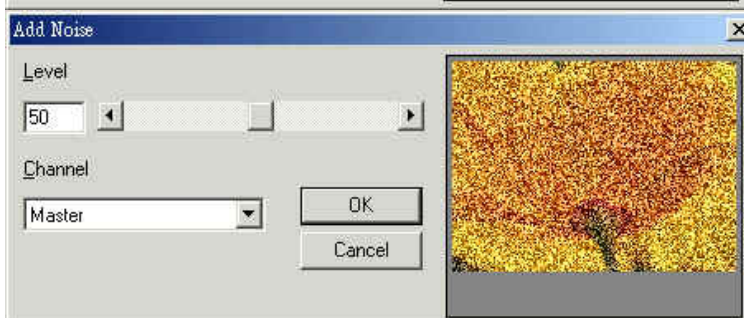

4.4.1.7 Emboss

Click "Image – Effects - Emboss"

Create an exaggerated 3-D effect. Choose from different directions to give character to the depth of the image.

The original image:

MarkingMate



When the emboss direction is North, and the depth is 80:



4.4.1.8 Edge Enhance

Click "Image – Effects – Edge Enhance"

Automatically creates an enhanced outline of the image.

The original image:



After use this function:

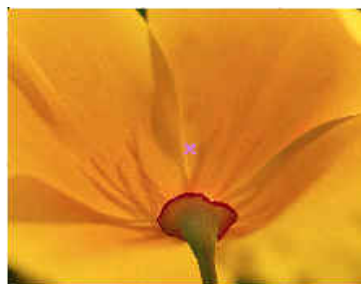

4.4.1.9 Oilify

Click "Image – Effects - Oilify"

Transform the image into an "oil painting." Create an exaggerated blurred effect.

The original image:



MarkingMate

When the sample size is 3:

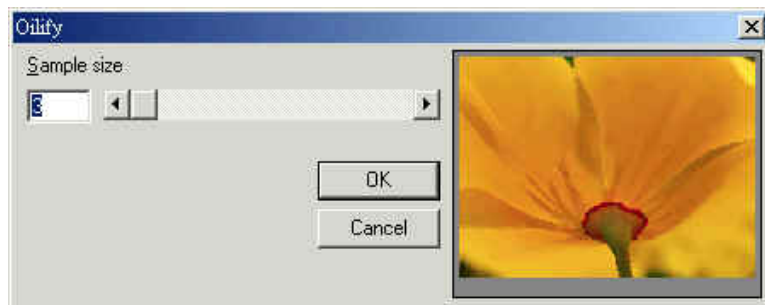

When the sample size is 7:

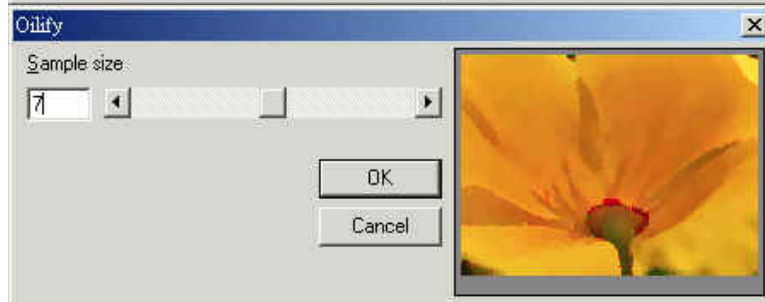

When the sample size is 11:

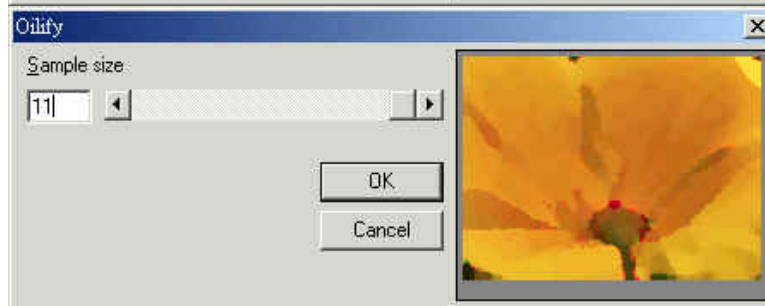

4.4.2 Special Filters

4.4.2.1 Gradient

Click "Image – Special Filters - Gradient"

The original image:



When the Filter Value is North:



MarkingMate

When the Filter Value is North-East:



4.4.2.2 Laplacian

Click "Image – Special Filters - Laplacian"

The original image:



When the Filter Value is Filter 1:

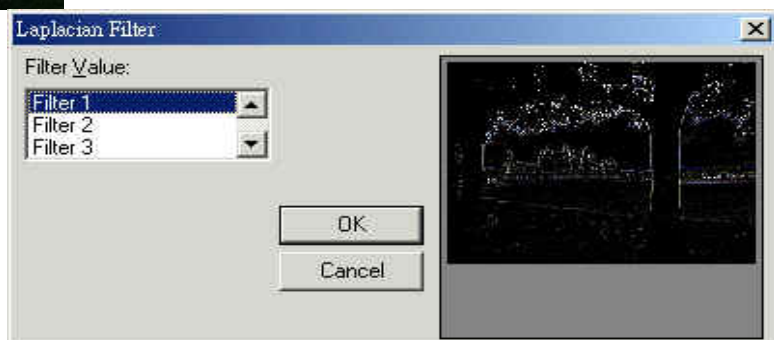

When the Filter Value is Filter 2:

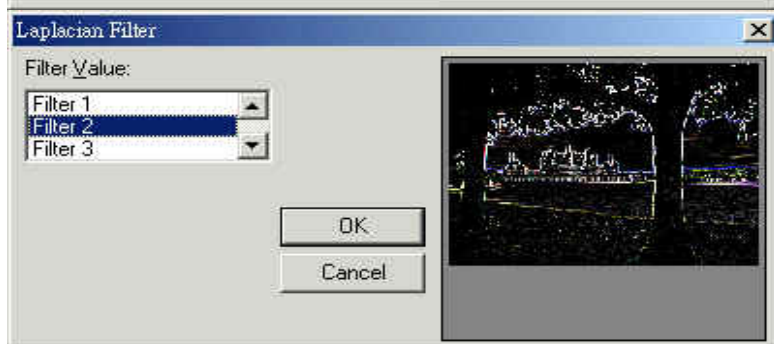

4.4.2.3 Sobel

Click "Image – Special Filters - Sobel"

The original image:

MarkingMate



When the Filter Value is Horizontal:



When the Filter Value is Vertical:

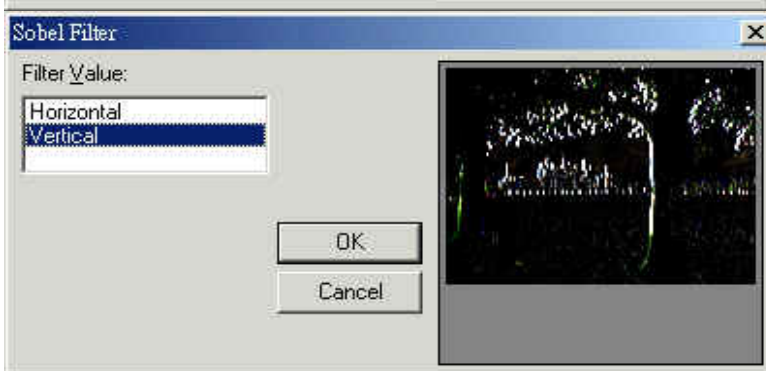

4.4.2.4 Prewitt

Click "Image – Special Filters - Prewitt"

The original image:



MarkingMate

When the Filter Value is Horizontal:

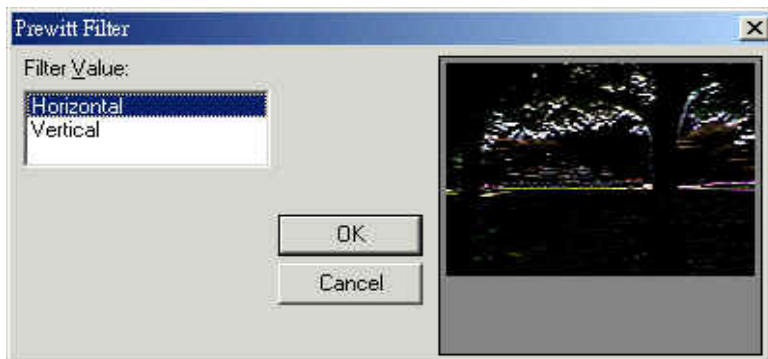

When the Filter Value is Vertical:



4.4.2.5 Shift Difference

Click "Image – Special Filters – Shift Difference"

The original image:



When the Filter Value is Diagonal:

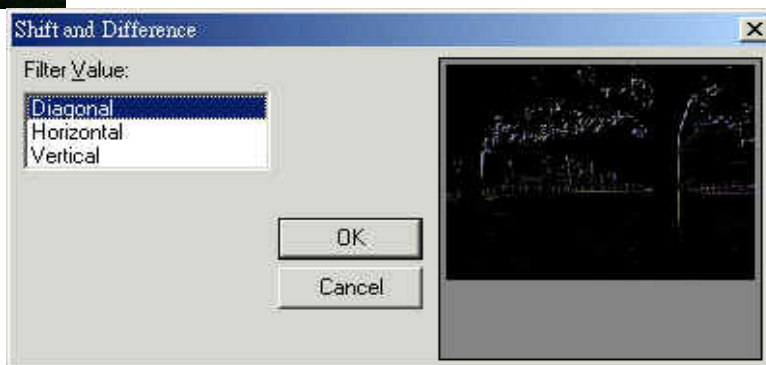

MarkingMate

When the Filter Value is Horizontal:



When the Filter Value is Vertical:



4.4.2.6 Line Segment

Click "Image – Special Filters – Line Segment"

The original image:



When the Filter Value is Horizontal:

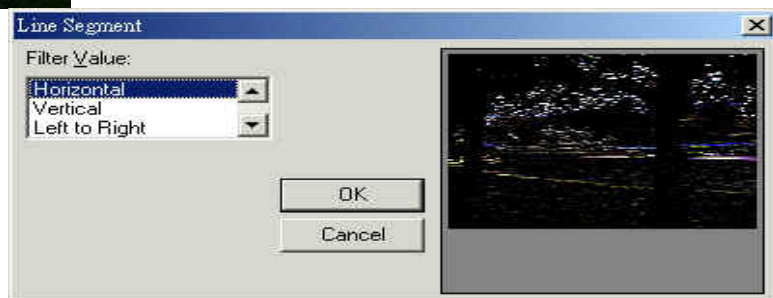

MarkingMate

When the Filter Value is Vertical:

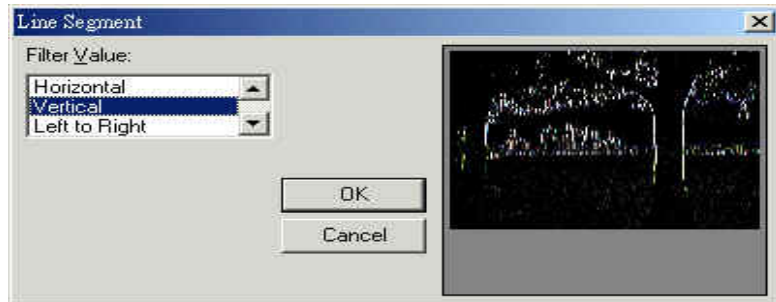

When the Filter Value is Left to Right:

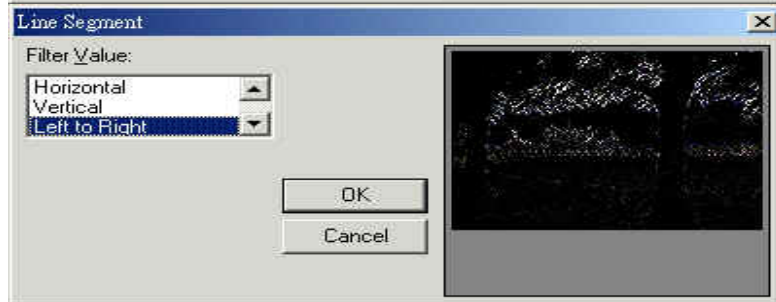

When the Filter Value is Right to Left:

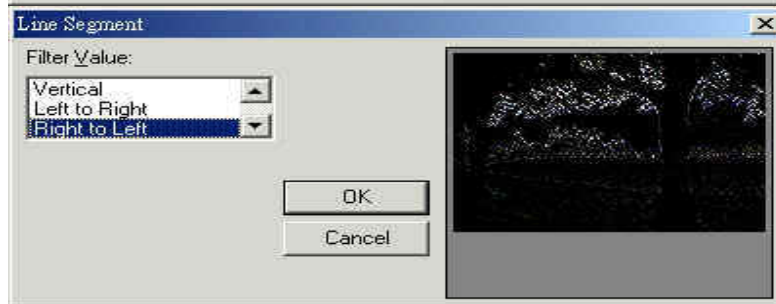

MarkingMate

4.5 Color Menu

“Color” menu offers the following functions:

Gray Scale

Color Resolution

Brightness

Contrast

Hue

Saturation

Gamma Correct

Intensity

Histogram

Invert

Solarize

MarkingMate

4.5.1 Gray Scale

Click "Color – Gray Scale"

Automatically transforms a colored image into an 8-bit grayscale image.

The original image:



After use the function:



4.5.2 Color Resolution

Click "Color – Color Resolution"

Edit the bits per pixel ratio and the type of palette used on the image. If 1 bit per pixel is chosen, you will need to select a type of dithering method.

The original image:



When the Bits Per Pixel is set to 32-bit, and the Color Order is Blue-Green-Red (BGR):



When the Bits Per Pixel is set to 8-bit, and the Dither Method is Ordered, and the Palette is Fixed Palette:

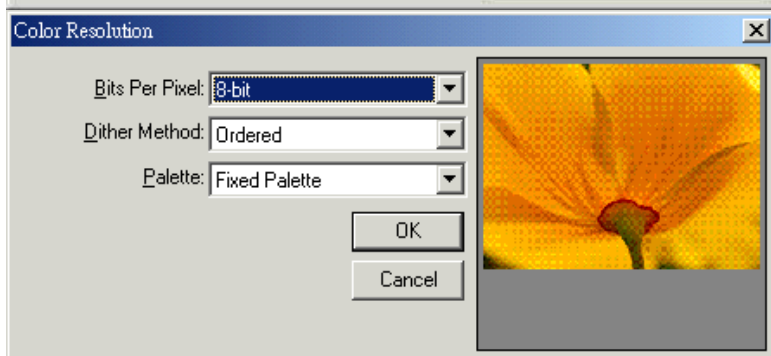

MarkingMate

4.5.3 Brightness

Click "Color - Brightness"

Increase the brightness from +100% (bright white) to –100% (pitch black).
The original image:



When the Brightness percentage is –36:

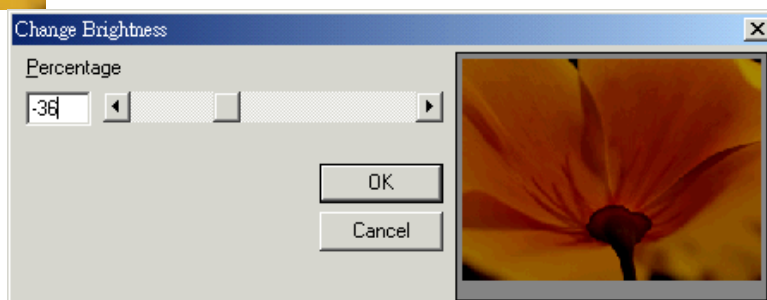

When the Brightness percentage is 0:

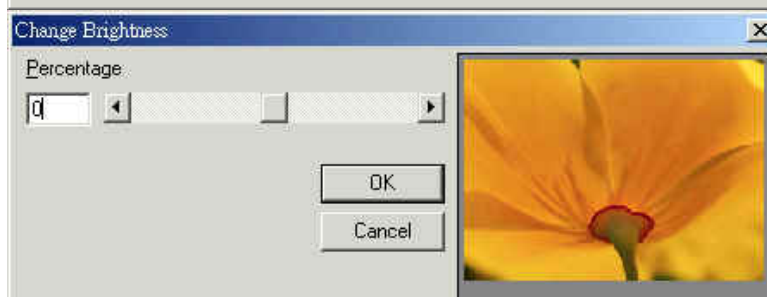

When the Brightness percentage is 24:



4.5.4 Contrast

Click "Color - Contrast"

Adjust the contrast levels from +100% (bright) to –100% (dark).
The original image:

MarkingMate



When Contrast Percentage is -48:

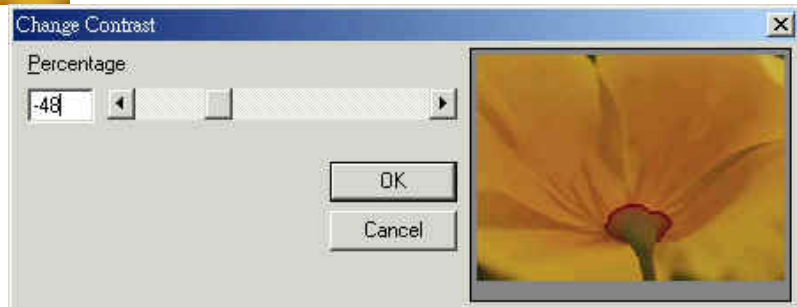

When Contrast Percentage is 0:



When Contrast Percentage is 30:



4.5.5 Hue

Click "Color - Hue"

Change the hue of the image to equal 360° of the color spectrum.
The original image:



MarkingMate

When the Hue Angle is -139 :

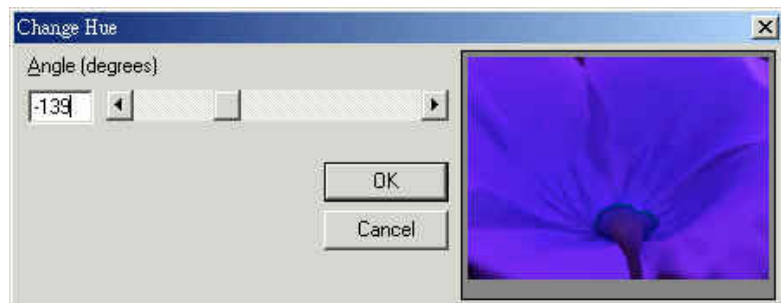

When the Hue Angle is 0:



When the Hue Angle is 133:

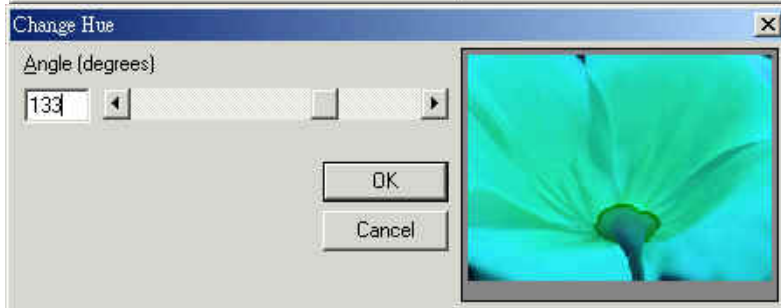

4.5.6 Saturation

Click "Color - Saturation"

Add or remove color.
The original image:



When the Saturation Percentage is -80 :

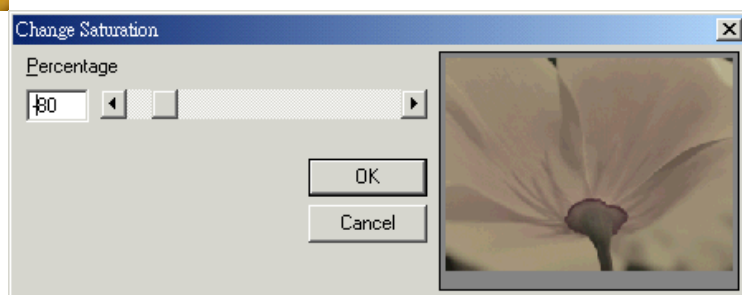

MarkingMate

When the Saturation Percentage is 0:



When the Saturation Percentage is 61:

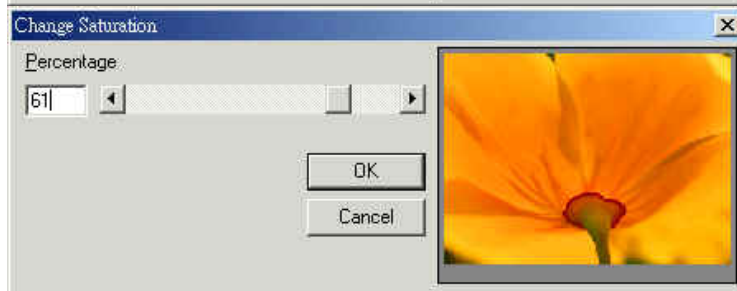

4.5.7 Gamma Correct

Click "Color – Gamma Correct"

Correction for image management. Adjust the levels of bright and dark inside the image.

The original image:



When the Gamma Correct Value is 0.43:

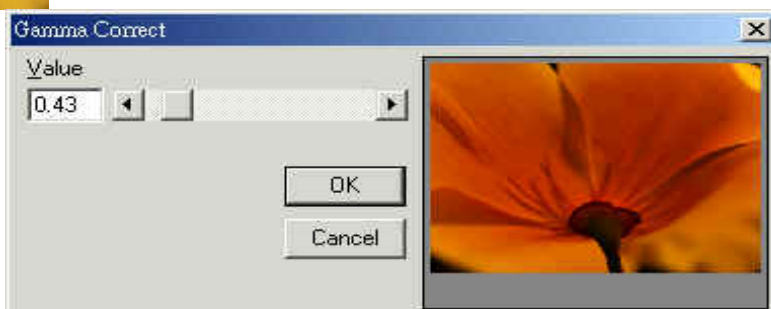

When the Gamma Correct Value is 1:

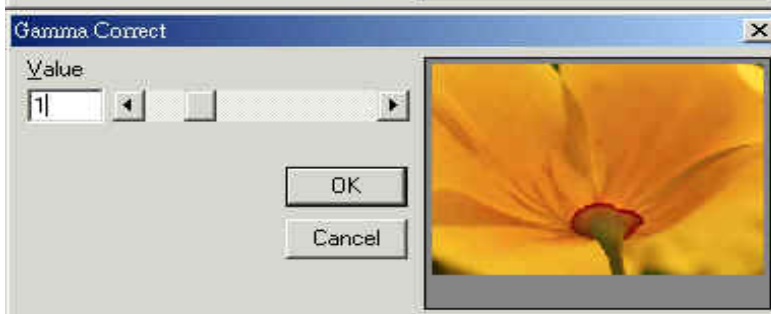

MarkingMate

When the Gamma Correct Value is 1.79:

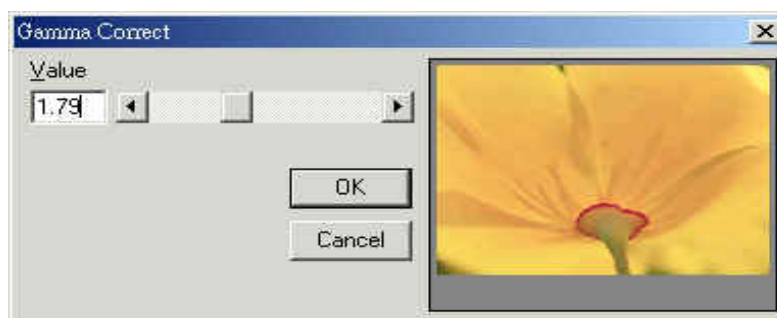

4.5.8 Intensity

Click "Color - Intensity"

Detect

This function is used to detect the image intensity.

Spread

This function is used to change the image intensity according to the previous settings.

4.5.9 Histogram

Click "Color - Histogram"

Equalize

Use this function to equalize the image.

The original image:



After use this function:

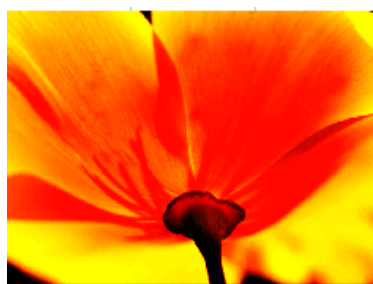

HistoContrast

Use this function to the the HistoContrast of the image:

The original image:



MarkingMate

When the HistoContrast Percentage is -83:

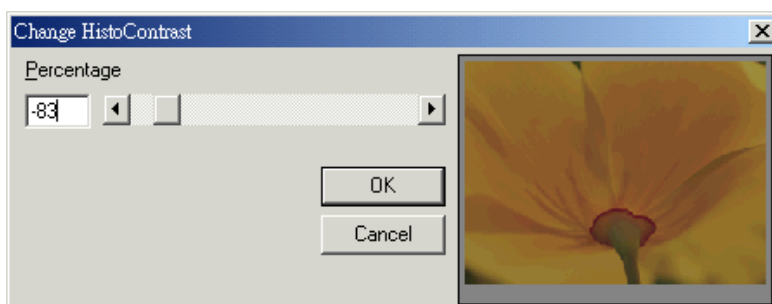

When the HistoContrast Percentage is 0:

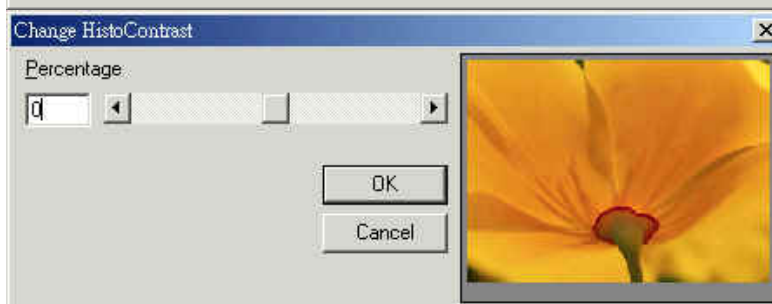

When the HistoContrast Percentage is 79:

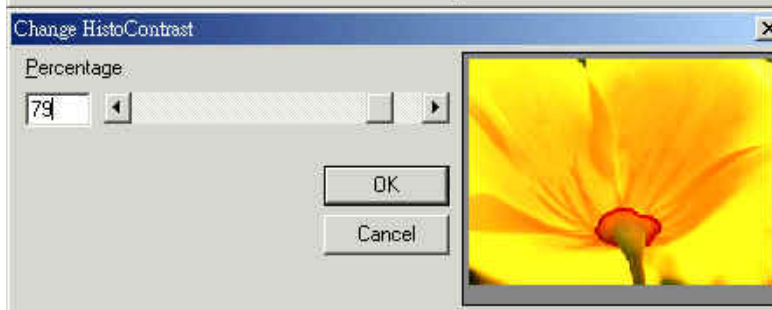

4.5.10 Invert

Click "Color - Invert"

Invert the Colors of the image. Black will become white; white will become black, etc.

The original image:



After use this function:



4.5.11 Solarize

Click "Color - Solarize"

Create a "midnight" effect. Change the level of shadows that are cast on the image.

The original image:

MarkingMate



When the Solarize
Threshold is 17:

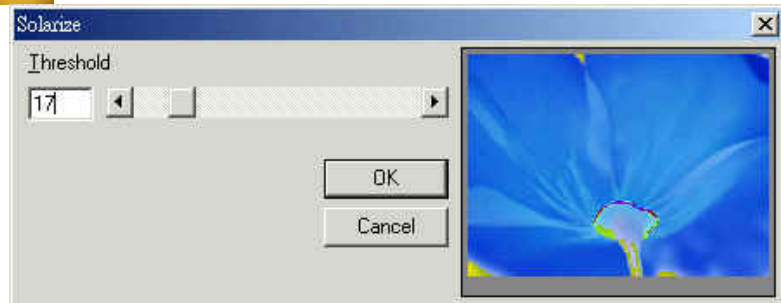

When the Solarize
Threshold is 61:



When the Solarize
Threshold is 120:

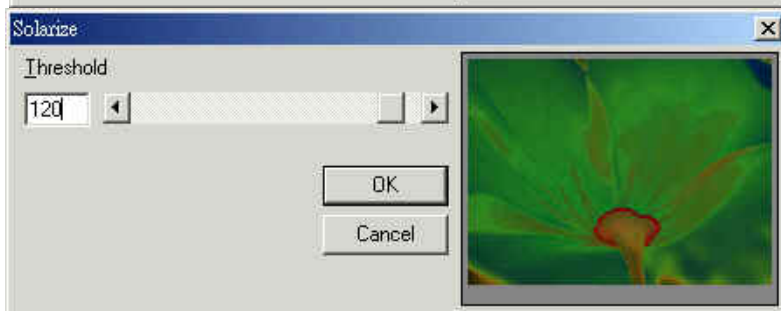

MarkingMate

4.6 Execute Menu

"Execute" menu offers the following function:

Marking	Set the object parameters and execute the marking sequence.
Quick Mark	Execute marking.
Align Test	Allow users to examine the mark position is correct or not.
User Level	User Level can be divided into Operator, Programmer, and Administrator to separate user's authorities.
Param List	Allow users to name, file, and reuse the marking parameters.
Rotary Marking	Provide three common used rotary marking functions.

MarkingMate

4.6.1 Marking

Mark the objects and adjust the related settings.

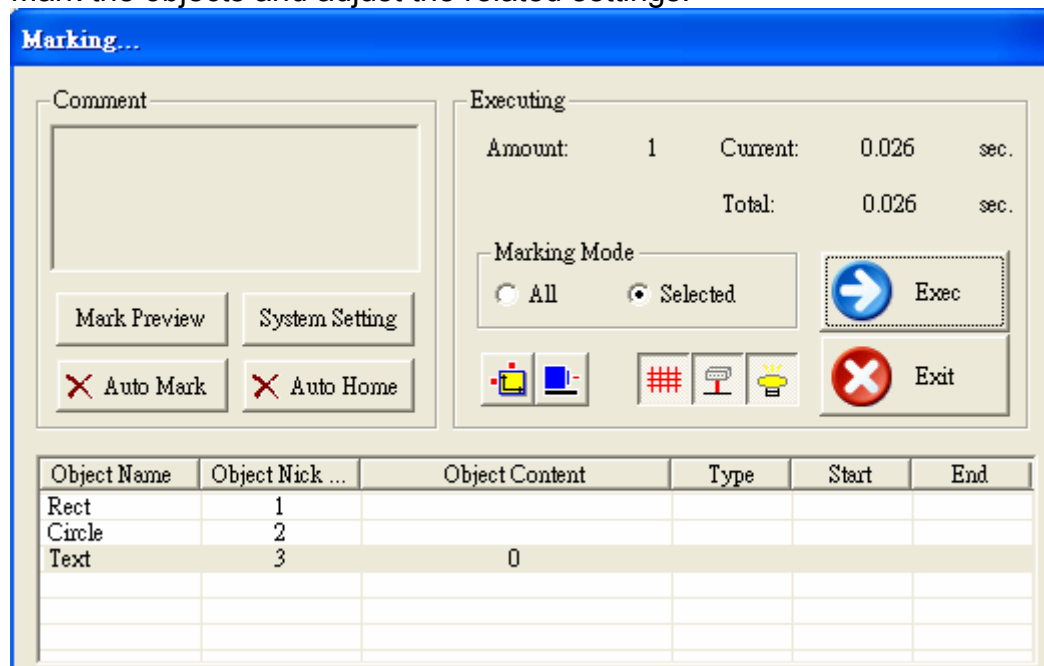

1. **Comment:** Write down some notes about this file's functions and points for attention over here. You can push the "Mark Preview" button to see the mark preview (as description in the next page). As to modify the comments, just push the button of "System Setting", a dialogue box of "Global Parameters" will be displayed as description in the next two pages:

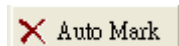

– Press "Auto Mark" button will show a dialogue box as below. Check the checkbox of "Enable" to enable this function, and press "ESC" if you want to stop it in the midway. If the function is enabled, the button changed to be:

Delay – The interval between each Auto Mark execution.

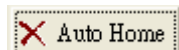

– Press "Auto Home" button will show a dialogue box as below. Check the checkbox of "Enable" to enable this function. If the function is enabled, the button changed to be:

This function will do homing at first and after a specific mark times (enter a specific number in the box of "C=") then let the Rotary, or X-Axis, or Y-Axis (only with check mark in the checkbox) to execute "Auto Home" again.

MarkingMate

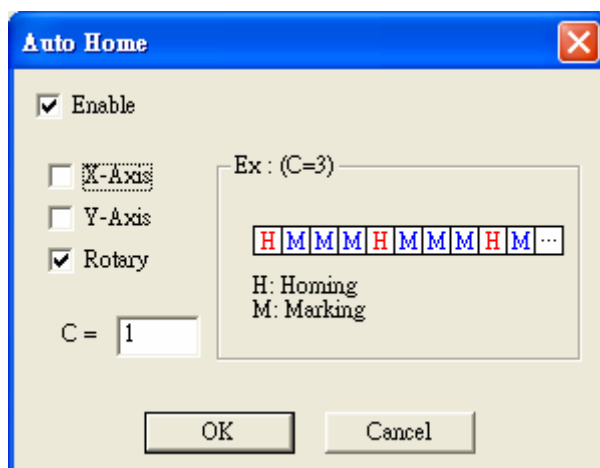

2. **Executing: Amount** – Display the current mark times.
Current – The current time of marking.
Total – The total time of marking.
Marking Mode – Execute All objects or selected objects.

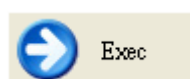

– Start executing marking.

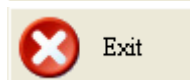

– Exit the executing dialogue box and stop marking.



: XY-Table Panel Control and Rotary Panel Control (please refer to the description of section 4.7.10.1 and section 4.7.10.2).



: The buttons to control the power on/off of **shutter**, **align**, and **light** separately.

3. **Footnote:** All objects' name and contents will be displayed over here.

MarkingMate

Preview

This function is useful to reposition the designated center of the marked object. When you push “Run” button, a red light instead of laser shooting can help you find if it is reposition well. If the material to be marked is fixed under the machine and the desired center point of the object is 3 mm below the actual center point, then change the Unit value to 1 mm and click DOWN arrow button three times to move the center point down.

Speed: speed of align light.

Unit: the shifting unit

Run Mode: you can choose to run in bounding path or full path

Selected Only: only for the selected object

Run: start executing this function

Modify Objects: the real object data does not being modified until you push this button.

Align Adjust: when the laser does not match with align light, you can push this button to adjust the offset, scale, and rotate angle of the align light.

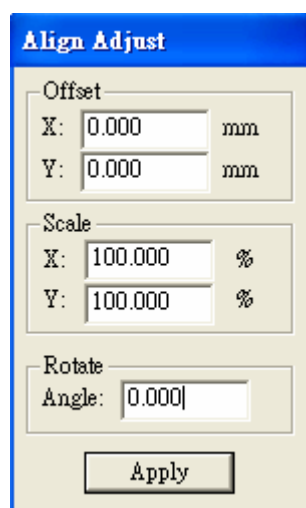
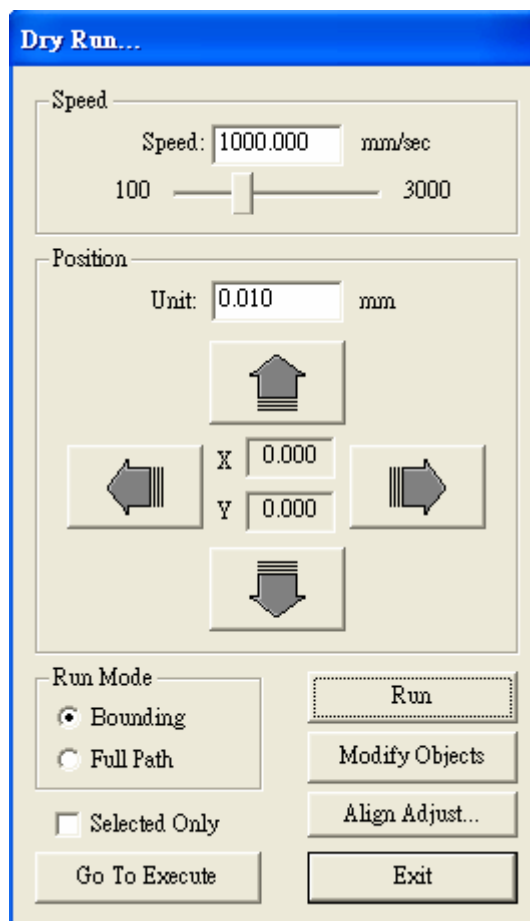

Go To Execute: Go back to the Execute dialogue box.

Exit: close this function

System Setting

In the dialogue box of Execute Marking, if you press the “System Settings” button will see a “Global Parameters” box as below:

Global Parameters

MarkingMate

The screenshot shows the 'Global Parameters...' dialog box. It features several input fields and checkboxes. At the top left, 'Marking Max' is set to 0, 'Marking Amount' to 1, and 'Trigger Max' to 0. Below these are checkboxes for 'Show MSG' (unchecked) and 'Show Object List' (checked). A 'Comment' text area is on the right. The 'Mark On Fly' section is divided into two columns: 'X Axis' (checked) with 'X Encoder' (unchecked), 'Speed' at 0.000 mm/sec, and 'Delay' at 0 us; and 'Y Axis' (checked) with 'Y Encoder' (checked), 'Factor' at 0.000 mm/cnt, and 'Delay' at 0 pulse. At the bottom, there are three checked checkboxes: 'Auto Shutter', 'Auto Align', and 'Auto Lamp'. Three buttons are present: 'Poly Delay Table', 'Power Setting', and 'Laser Setting'. At the very bottom are 'OK' and 'Cancel' buttons.

Marking Maximum: The desired total working times

This function will allow you to avoid the unwilling excess working pieces.

Marking Amount: It enables you to take down how many work pieces you have already done

Trigger Max: Specify the counts of marking for trigger. Show the message for trigger.

Show MSG: If checked, the system will show a warning message of "Trigger count is over limit" while the marking amount reaching the Trigger Max value.

Show Object List: If checked, all object names and their contents will be displayed in the Marking dialogue as below:

MarkingMate

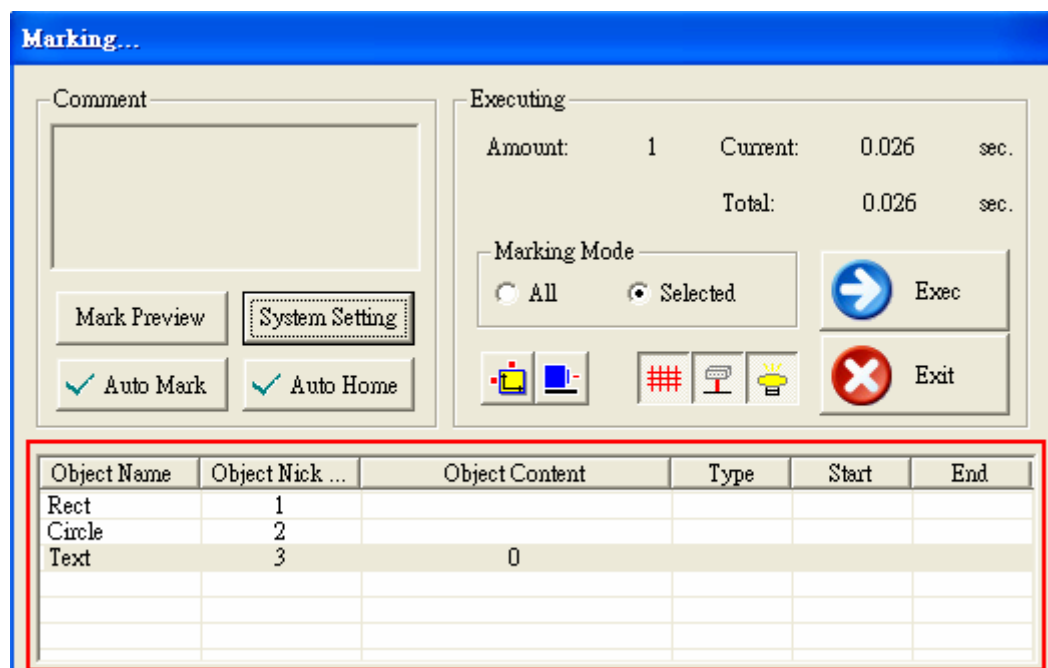

Comment: Input a summary of the file.

Mark on Fly

It enables you to mark while the working pieces are moving. You can choose to use this function on X or Y Axis.

X/Y Encoder checked:

Factor: the value of conveyer moving per encoder count.

Delay: delay a giving count pulse then start marking.

X/Y Encoder not checked:

Speed: the speed of conveyer.

Delay: delay a giving count pulse then start marking.

Auto Shutter/ Auto Align/ Auto Lamp: Allows system to do the auto setting (Default is checked.)

Poly Delay Table:

Press the "Poly Delay Table" button will show a dialogue box as below:

MarkingMate

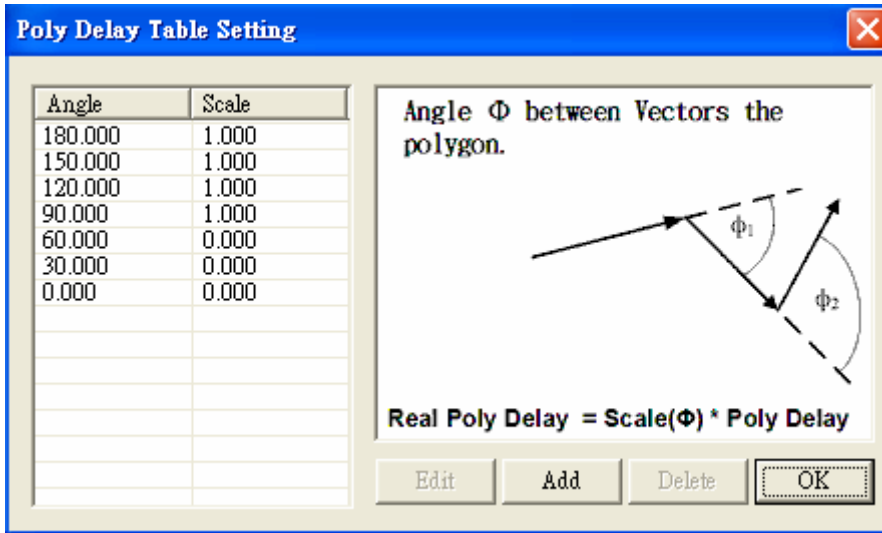

The value of Angle and Scale will effect the Poly Delay time in the setting of Delay page of Property Table in section 6.2.3. IT follows the rule as description below:

For more accurately control the marking quality of the corner or the cross of two line segments, the system offers another method. Users can go to the directory of C:\Program Files\MarkingMate, open the config.ini file, change the setting of “VariablePolyDelay=0” to “VariablePolyDelay=1”, save the file and restart the program.

If the setting is “VariablePolyDelay=0” that means no matter how big the cross angle is the Poly Delay follow the delay parameter setting. And if change to “VariablePolyDelay=1”, the system will change the Poly Delay time in accordance with angle, its calculation rule is:

$$\text{DelayTime}(\phi) = \text{scale}(\phi) \cdot (\text{Poly Delay})$$

Among the above formula, scale(ϕ) is a ratio value between 0 and 2. Please note that ϕ is a supplementary angle of an included angle, and it is calculated as below:

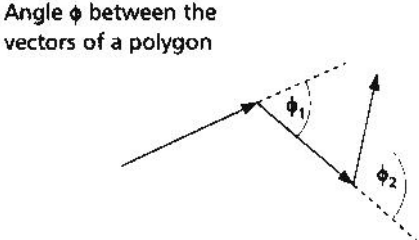

MarkingMate

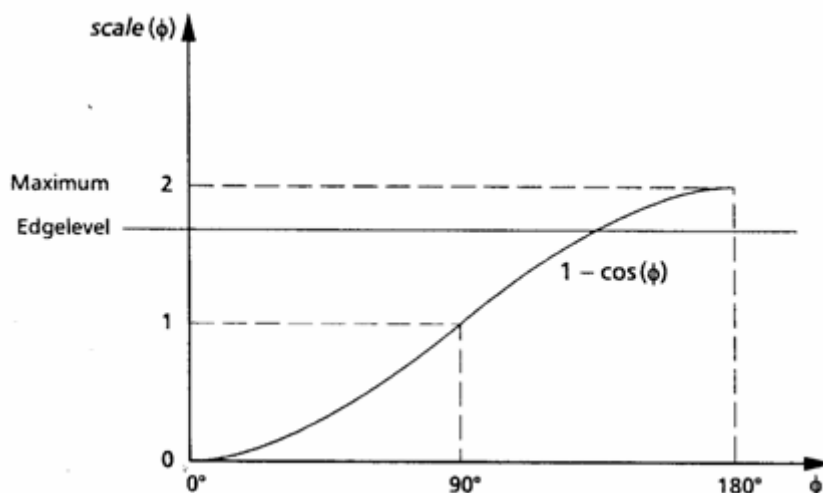

Press “**Add**” button will display the dialogue box of “Poly Delay Table Editor” as below for you to enter the new value of angle and scale.

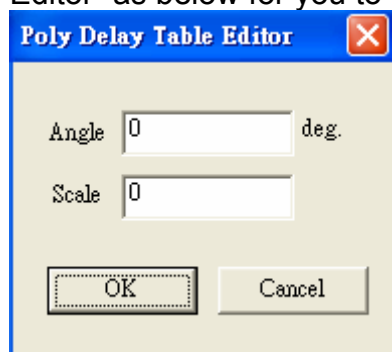

Power Setting:

Press the “**Power Setting**” button will show the “Power Setting” dialogue box as below. The page allows you to set up the time for full power variation and delay time for being steady. Moreover, you can set how much time to enter power saving mode and the power percentage during idle time.

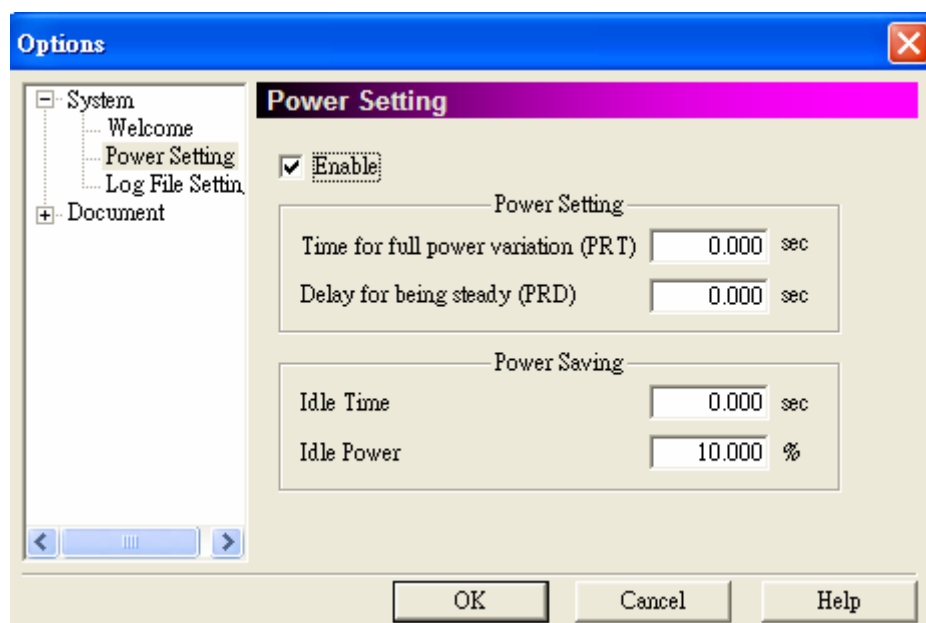

MarkingMate

Laser Setting:

Only when you choose the “SPI_fiber” driver in the Driver Manager of MarkingMate can active the dialogue box as below. If you need to set up the parameters in this page, please refer to the user manual of SPI Laser.

SPI Fiber Laser (G3) Setting...

Laser Mode

Pulsed Mode [SC 3]

CWM Mode [SS 3]

Waveform No. [SW] :

Duty Factor (0 ~ 1000) [SF] :

Stand-by Current (0 ~ 100) [SH]

Temperatures :

Query Status [QS]

Status Value :

Alarm Flag
System Alarm
Beam Delivery Alarm
Temperature Alarm
Interlock Closed
Laser Not Reay
Laser Output Requested

Query Alarm [QA]

Alarm Value :

Laser Not Responding
Interlock Open
Seed laser diode temperature fault

MarkingMate

4.6.2 Quick Mark

Different from Marking, Quick Mark can:

1. Select to mark repeatedly, and press **ESC** to stop.
2. Choose all objects or the selected objects.
3. When use this function, the system will neglect the setting of the drawing objects.

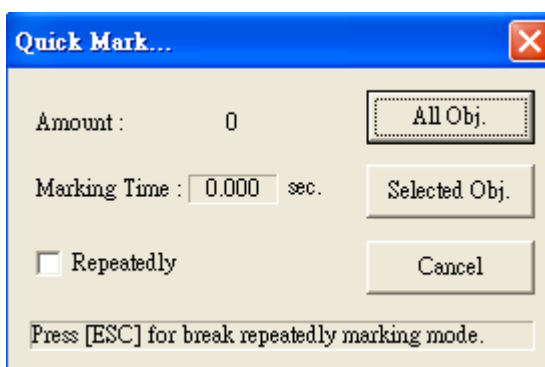

4.6.3 Align Test

Speed

Speed: Represent the speed of the align light. Modify it by key in the value or move the scrollbar directly.

X: Click "X" button, the align light will shift toward the X direction.

Y: Click "Y" button, the align light will shift toward the Y direction.

Stop: Click "Stop" button, the align light will stop.

Move

X: Displacement to X direction (unit: mm)

Y: Displacement to Y direction (unit: mm)

Go: Click "Go" button, the align light will adjust the X/Y position according to the X/Y displacement.

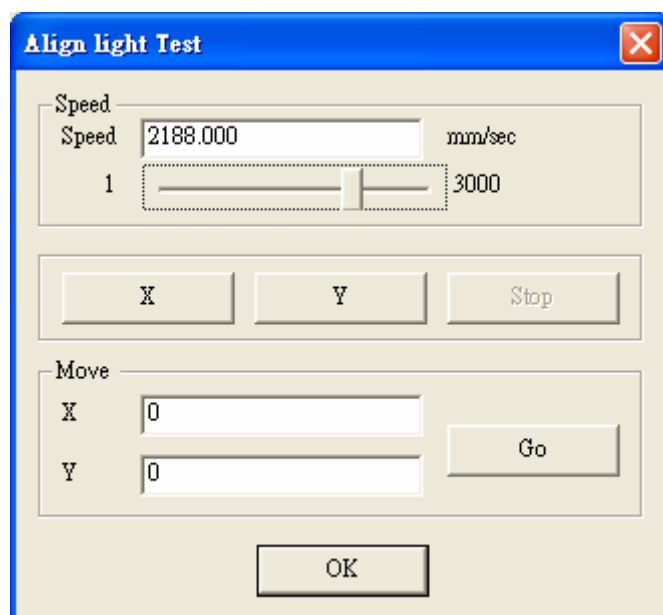

MarkingMate

4.6.4 User Level

Users are allowed to execute different functions according to their authorities.
Operator: Operator level users can only read files and output files and use limited functions.

Programmer: Programmer level users are allowed to draw and edit objects and can only use limited functions which is not include system parameter settings.

Administrator: Administrator level users are able to draw and edit the setting of objects and use all the functions. Administrators can modify their passwords.

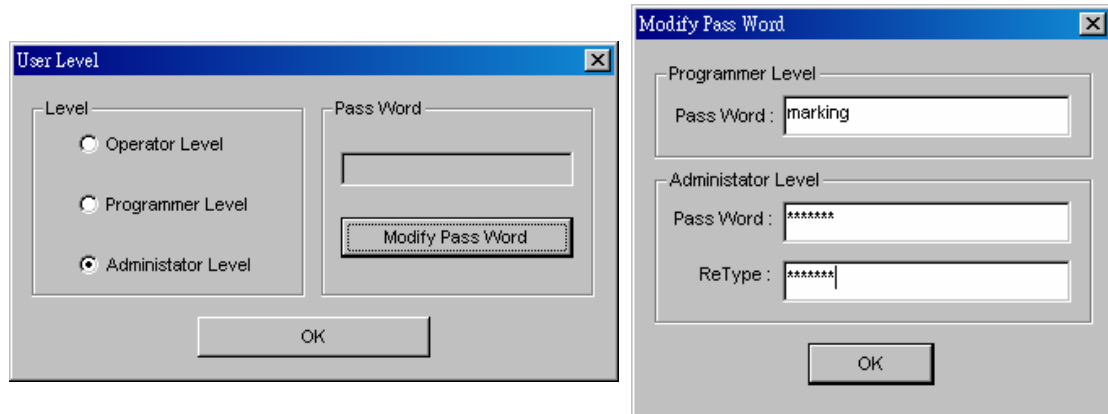

MarkingMate

4.6.5 Mark Parameter List

This list is shown all the marking parameters for your purpose. You can name, sort, and store these marking parameters for future use.

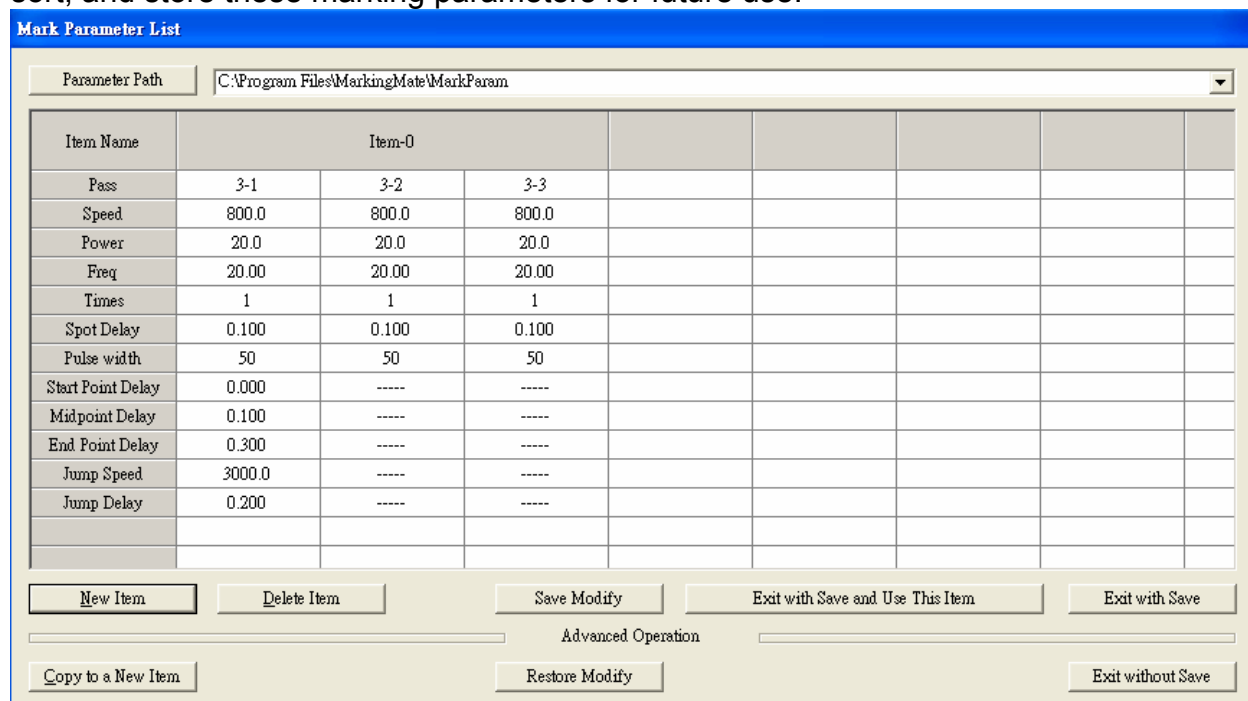

Parameter Path	The directory of parameter list.
Item Name	The name of this item
Pass	Cycle (maximum 5, if the number is larger than 1, the times below can only set to be 1)
Speed	Mark speed
Power	Mark power (maximum 100)
Freq	Mark frequency
Times	Mark times
Spot delay	Spot marking delay time
Pulse width	The width of pulse (only for YAG)
Start Point Delay	The time difference between start laser order and laser hit time. This value is adjustable to get better marking quality.
Mid Point Delay	This value will affect the quality of joins.
End Point Delay	This value will affect the quality of end points.
Jump Speed	Laser jump speed
Jump Delay	When laser reached the assigned position, it will shoot after this delay time.
New Item	Create a new item
Delete Item	Delete the selected item
Copy to a New Item	Copy the selected item to a new item

MarkingMate

Save Modify	Save the data you modified
Restore Modify	Back to the item without modified
Exit with Save and Use this Item	Use the select item and save and exit
Exit with Save	Save and exit
Exit without Save	Exit without save

Example:

◆ Create a new directory and new item:

Click “Execute – Marking Param List” in the menu, when the dialogue box appeared, click the “New Item” button and a default setting will appear.

The default item name is “Item-0”, click it is able to change name. So are the others.

◆ Using the mark parameters you created:

Select an object, then go to the Mark Parameter of the Property Table, and then click “.Load Parameter” button will enter the object parameter page.

Select the mark parameter you need and click “Exit with Save and Use this Item” button, the object will be marked as the mark parameter setting.

MarkingMate

4.6.6 Rotary Marking

The system provides three common used rotary marking functions as below. Users can refer to the user manual of “**Rotary Axis of MarkingMate**” to see the detail descriptions.

1. Calibration Marking
2. Ring Text Marking
3. Cylinder Marking
4. Motor Setting

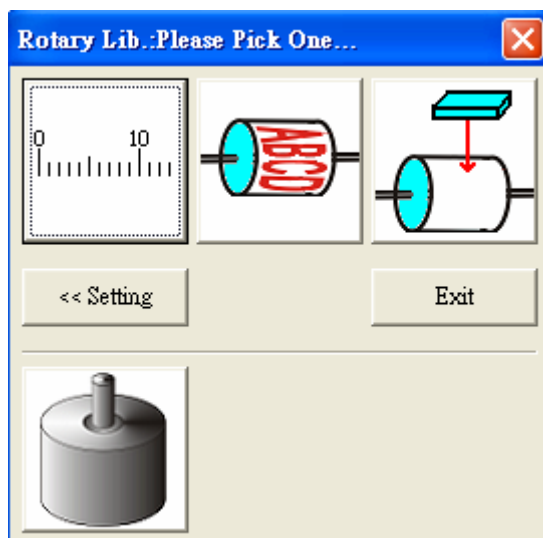

MarkingMate

4.7 View Menu

“View” menu offers the following function:

Standard Bar	Enable/disable Standard Bar
Zoom Bar	Enable/disable Zoom Bar
Draw Bar	Enable/disable Draw Bar
Layer Bar	Enable/disable Layer Bar
Object Browser	Enable/disable Object Browser
Modify Bar	Enable/disable Modify Bar
Dimension Bar	Enable/disable Dimension Bar
Obj Property Bar	Enable/disable Object Property Bar
Control Tool	Enable/disable Control Tool
Laser Mark	Enable/disable Laser Mark
Laser Panel	Enable/disable Laser Panel
Status Bar	Enable/disable Status Bar
Welcome	Enable/disable Welcome screen
Composing Setting	
Show Order	Show the mark order
Tooltips	Enable/disable Tooltips
Tooltips Setting	Go to the Tooltips setting page of Options
Ruler	Enable/disable Ruler
Ruler Setting	Go to the ruler setting page of Options
Grid	Enable/disable Grid
Grid Lock	Enable/disable Grid Locking
Grid Parameter	Grid Parameter setting
Zoom In	Enlarge a specific area
Zoom Out	Shrink a specific area
Zoom Previous	Go back to the previous view
Zoom All	Show the whole Work Area
Zoom Extend	Show all graphics
Show Hatch Line	Show the hatch line









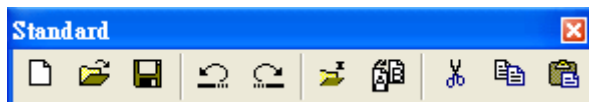

MarkingMate

4.7.1 Standard Bar

The toolbar allow users to use a lot of common use tools more conveniently. You can move the toolbar to any places you like by clicking and moving it. Click "View" from Menu Bar will see a list of toolbars, the toolbar with a "v" mark means opened. Following is the introduction to the toolbar.

The Standard Bar is listed as below:







New		Create a new document.
Open		Close an existing mark file.
Save		Save the current document using the existing file name.
Undo		Cancel an unwanted action.
Redo		Repeat a cancelled action.
Import		Import a graphics files and convert it into the mark format.
Replace		Replace the selected object by a new object
Cut		Remove selected data and store it in the clipboard for future use.
Copy		Duplicate selected data and store it in the clipboard for future use.
Paste		Attach data from the clipboard to the current document.

4.7.2 Zoom Bar

The Zoom Bar is listed as below:



Zoom in		Enlarge a specific area.
Zoom out		Shrink a specific area.
Zoom previous		Go back to the previous view.
Zoom all		Show the whole Work Area.
Zoom extend		Show all graphics in the Work Area.

MarkingMate

4.7.3 Draw Bar

The Draw Bar is listed as below:

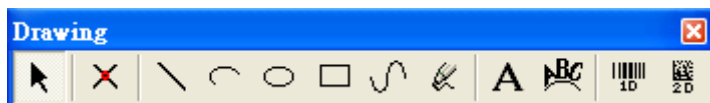

Selection		Selects or deselects objects in the Work Area.
Line		Inserts straight lines from point-to-point-to-point.
Arc		Creates arcs, circles, and spirals.
Circle		Creates circles and ovals.
Rectangle		Creates squares and rectangles.
Curve		Creates a curve using three points of reference.
Curve Brush		Draws freehand lines by the mouse.
Text		Inserts text in the Work Area.
Arc Text		Inserts text based on an arc.
1D Barcode		Creates 1D barcode.
2D Barcode		Creates 2D barcode.

4.7.4 Layer Bar

The Layer Bar is listed as below:



Layer Manager		The layer page of Property Table will show up for editing
New Layer		Create a new layer
Delete the Active Layer		The active layer will be deleted
Current Layer	Layer-1	Select the current layer
Layer Color		Layer color settings
View Layer		Enable or disable view layer
Edit Layer		Enable or disable edit layer
Output Layer		Enable or disable output layer

MarkingMate

4.7.5 Object Browser

The Object Browser is as below:

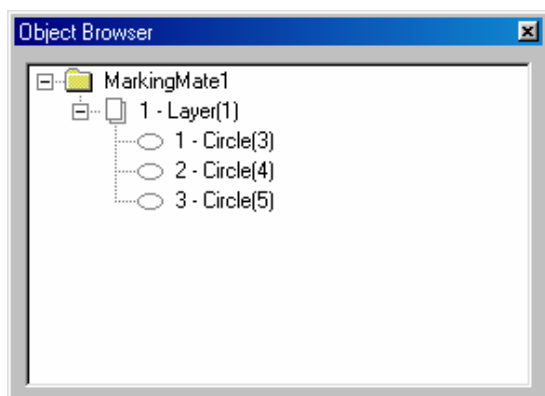

4.7.6 Modify Bar

The Modify Bar is as below:



X of Center		The X-axis value of the center of the object
Y of Center		The Y-axis value of the center of the object
Width		The width of the selected object
Height		The height of the selected object
X of Scale		The scale of the width of the selected object
Y of Scale		The scale of the height of the selected object
Lock to Same Ratio		The width and height will be adjusted in the same ratio.
Mirror Horizontally		Invert an image on its horizontal axis. Left will become right and vice-versa.
Mirror Vertically		Invert an image on its vertical axis. Up will become down and vice-versa.
Angle of Rotating		The rotate angle of the selected object
X of Rotating Center		The X-axis value of rotating center
Y of Rotating Center		The Y-axis value of rotating center
Move to the Center		Move the position to the center

MarkingMate

4.7.7 Dimension Bar

The Dimension Bar is as below:

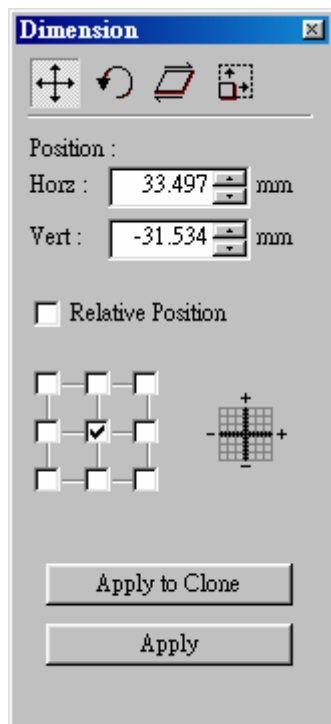

Position

Set the absolute or relative position

Rotate

Set the rotate angle and rotate center position

Aslope

Set the aslope angle

Scale

Set the scale of the object





4.7.8 Object Property Bar

When there is no object being selected, the Page Object Property Bar will be as below:











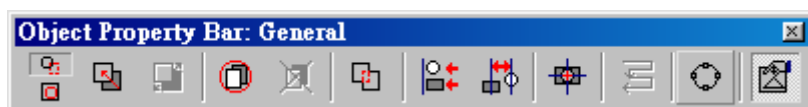





Origin X		The X-axis value of origin
Origin Y		The Y-axis value of origin
Page Width		The width of the page
Page Height		The height of the page
Change the Unit		The unit can be changed to mm or inch
Trim X		Edit the X trimming base
Trim Y		Edit the Y trimming base

MarkingMate

Grid X		Edit the X grid line
Grid Y		Edit the Y grid line
Open the Options Dialogue		Click this button can open the Options dialogue
Show or Hide the Property Table		Click this button will show or hide the Property Table

When there is an object being selected, the General Object Property Bar will be as below:











General Selection		A general situation
Transparent Selection		The selection of a group object
Combine		Combine two or more objects into one. This function will allow several objects to share the same property settings
Break		Do the inversion of Combine function
Group		Combine two or more objects into one. This function will allow several objects to move together while allowing their individual property settings to remain intact
UnGroup		Do the inversion of Group function
Welding		Combine two objects so that the outline remains while eliminating the overlapping lines
Alignment		Use this function to align the selected objects to the last selected object, paper edge, or paper center
Distribute		This function will adjust how the distance between a series of objects is calculated
Move to the Center		Move the selected object to the center of the Work Area.
Sort		Sort the connected parts of the selected object.
Trans-Curve		Transfer a curved line into a series of individual angled lines. Allows these single lines to be manipulated individually
Show or Hide the Property Table		Click this button will show or hide the Property Table

MarkingMate

4.7.9 Control Object

The Control Object is listed as below, its detail description please refer to section 4.3.12:







Digital In		Setting digital in signals
Digital Out		Setting digital out signals
Do Pause		Insert a pause into the marking sequence
Delay Time		Insert a delay into the marking sequence
Move To		Move the object to a position
Reset		Reset the setting
Loop		Create a loop path in the marking sequence
Ring		Insert a ring object into the marking sequence

4.7.10 Laser Mark

The Laser Mark panel is as below:



Dry Run		Allow users to reposition the object well, please refer to section 4.6.1.
Marking		Execute the marking function, please refer to section 4.6.1.
X-Y Table		Allow users to control X-Y Table (as description below)
Rotary Control Panel		Allow users to control the rotary axis (as description below)

4.7.10.1 X-Y Table

To control the XY Table, users must first activate the XY table function by clicking the layer object in Object Browser and go to the XY Table page of Property Table and check the “Enable” button and press the “Apply”

button. After doing that, click the  button and do the further setting in the dialogue box as below:

MarkingMate

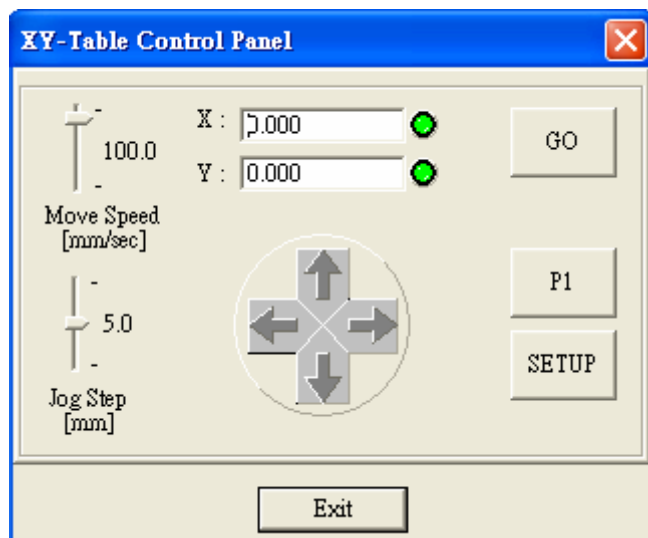

1. Input the X and Y values in the box and click “GO” button, the XY Table will move to that specific position. The moving speed can be adjusted by moving the speed bar by mouse.
2. Click the four direction buttons can also move the XY Table by the Jog Step. The Jog Step can be adjusted by mouse.
3. Click the button of “P1”, the XY Table will directly move to the setting position of P1. You can click “SETUP” button to reset the value of P1.
4. Click the “SETUP” button can do more settings as below:

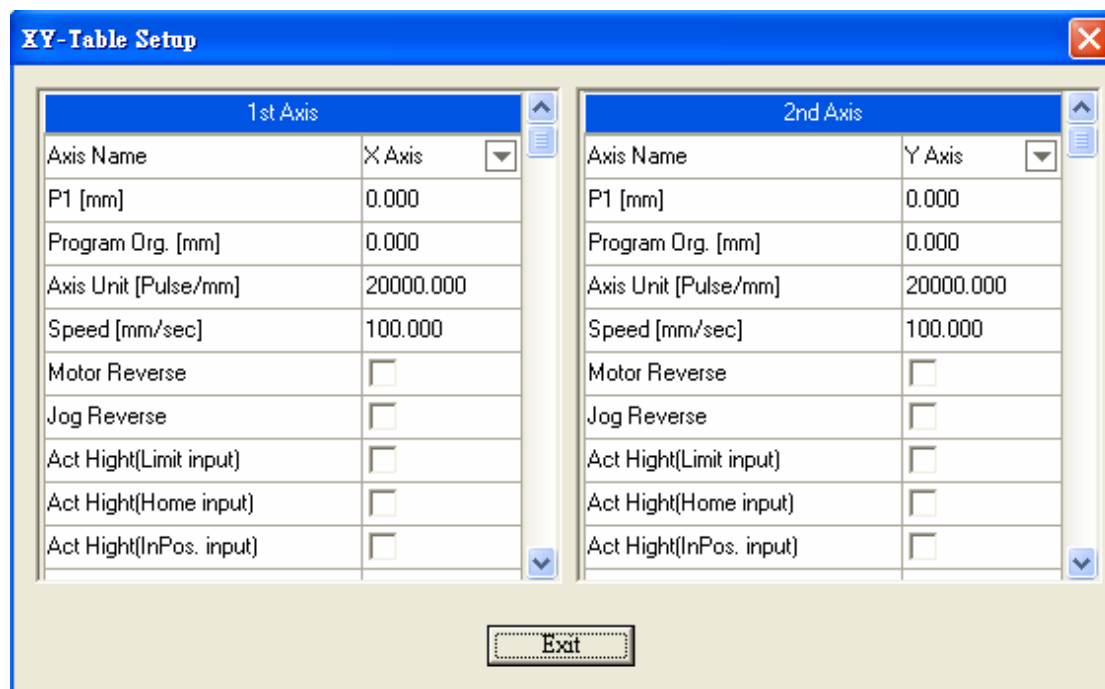

Axis Name: 1st Axis is X Axis, 2nd Axis is Y Axis, both two are changeable.

P1 [mm]: Fixed position (set any position you want).

Program Org. [mm]: The program will consider this point as the origin.

Axis Unit [Pulse/mm]: The pulse needs for each movement.

MarkingMate

Speed [mm/sec]: The moving speed of the XY Table.

Motor Reverse: The motor moves in the reverse direction.

Jog Reverse: When XY Table is placed in the different direction with the software control panel, this can make it changed to the right direction.

Act High [Limit Input]: If checked, the Limit signal of motor is active high

Act High [Home Input]: If checked, the Home Index signal of motor is active high

Act High [InPos. Input]: If checked, the In Position signal of motor is active high

ADD / DEC Time [sec]: The accelerate or decelerate speed of motor

Init. Speed [mm/sec]: The initial speed of motor

InPos Delay [sec]: The program will wait a time setting here to execute the next command.

XY Table Field [mm]: The maximum field that XY Table can move

4.7.10.2 Rotary Control Panel

To control the Rotary Axis, users must first activate the Rotary function by clicking the layer object in Object Browser and go to the Rotary page of Property Table and check the “Enable” button and press the “Apply”

button. After doing that, click the  button and do the further setting in the dialogue box as below:

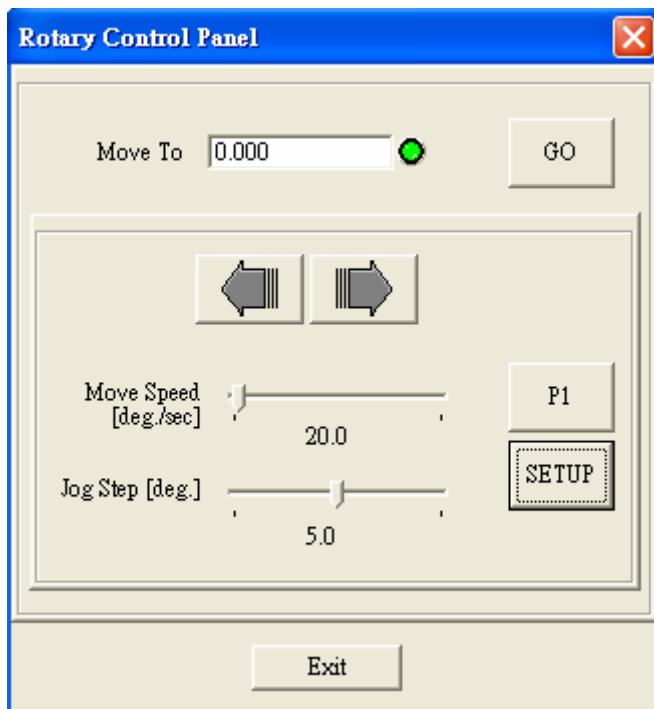

1. Input the degree value in the box and click “GO” button, rotary axis will rotate that specific angle. The rotating speed can be adjusted by moving the speed bar by mouse.
2. Click the two direction buttons can also move the rotary axis by the Jog Step degree. The Jog Step can be adjusted by mouse too.

MarkingMate

3. Click the button of “P1”, the rotary axis will directly rotate to the setting position of P1. You can click “SETUP” button to reset the value of P1.
4. Click the “SETUP” button can do more settings as below:

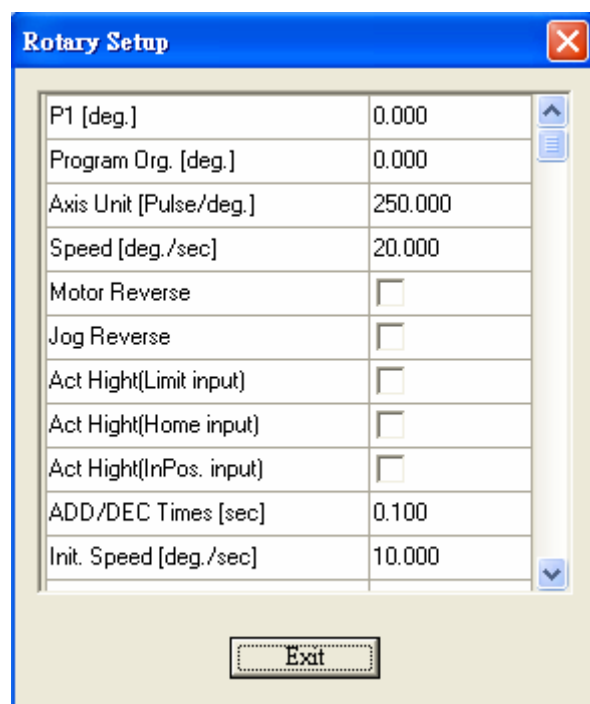

P1 [deg.]: Fixed position (set any degree you want).

Program Org. [deg.]: The program will consider this point as the origin.

Axis Unit [Pulse/deg.]: The pulse needs for each rotating.

Speed [deg./sec]: The rotating speed of the rotary axis.

Motor Reverse: The motor rotates in the reverse direction.

Jog Reverse: When rotary axis is placed in the different direction with the software control panel, this can make it changed to the right direction.

Act High [Limit Input]: If checked, the Limit signal of motor is active high

Act High [Home Input]: If checked, the Home Index signal of motor is active high

Act High [InPos. Input]: If checked, the In Position signal of motor is active high

ADD / DEC Time [sec]: The accelerate or decelerate speed of motor

Init. Speed [deg./sec]: The initial speed of motor

InPos Delay [sec]: The program will wait a time setting here to execute the next command.

Rotary Direction: Click here can do further settings of the rotating direction of the rotary axis.

Method of Mark End: Four ways for laser to go back to the origin after finishing marking job.



- ◆ Reverse Direction: by backward direction to the origin
- ◆ Shortest Path: by the shortest path to the origin
- ◆ Reset As Origin: the latest point will be reset as origin
- ◆ Forward Direction: by forward direction to the origin

MarkingMate

4.7.11 Laser Panel (optional)

The Laser Panel is as below:



Shutter ON/OFF		Control the shutter
Align ON/OFF		Control the align light
Lamp ON/OFF		Control the lamp

4.7.12 Status Bar

Enable or disable the Status Bar



Function description

The X, Y-axis value of the mouse position

When press the **Caps Lock** key, the **CAP** will appear.

When press the **Num Lock** key, the **NUM** will appear.

When press the **Scroll Lock** key, the **SCRL** will appear.

4.7.13 Welcome

Enable or disable the Welcome screen

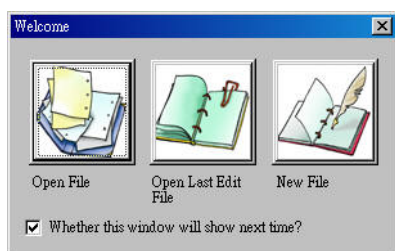

4.7.14 Composing Setting

Include tooltips, ruler, grid, and grid lock are setting here. The toolbar with a “√” mark means opened.

4.7.14.1 Show Order

Use this function can see the mark order of each objects as below:

MarkingMate

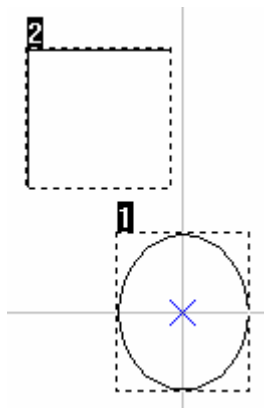

4.7.14.2 Tooltips / Tooltips Setting

The tooltips setting is as below:

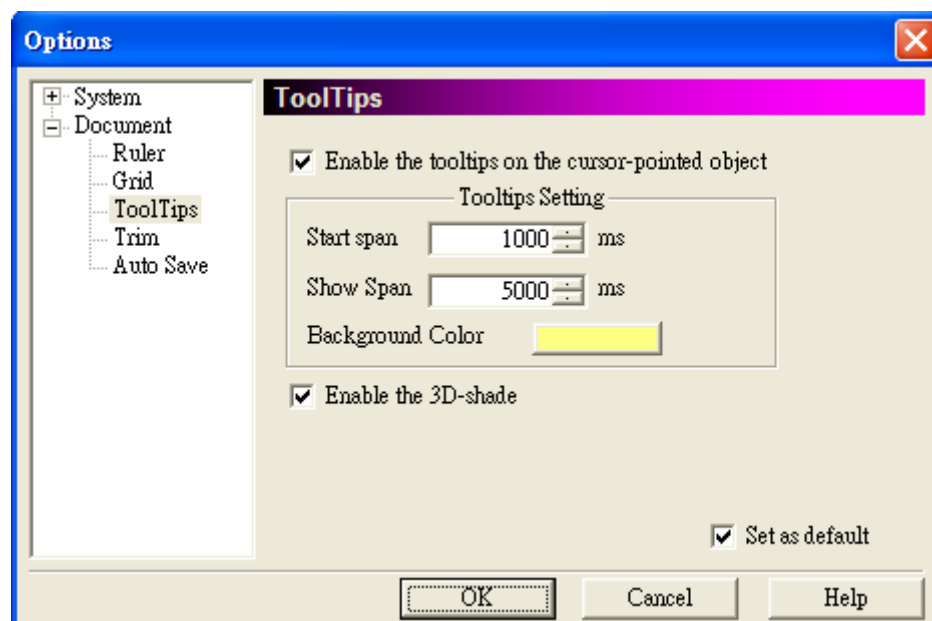

4.7.14.3 Ruler / Ruler Setting

The ruler setting is as below:

MarkingMate

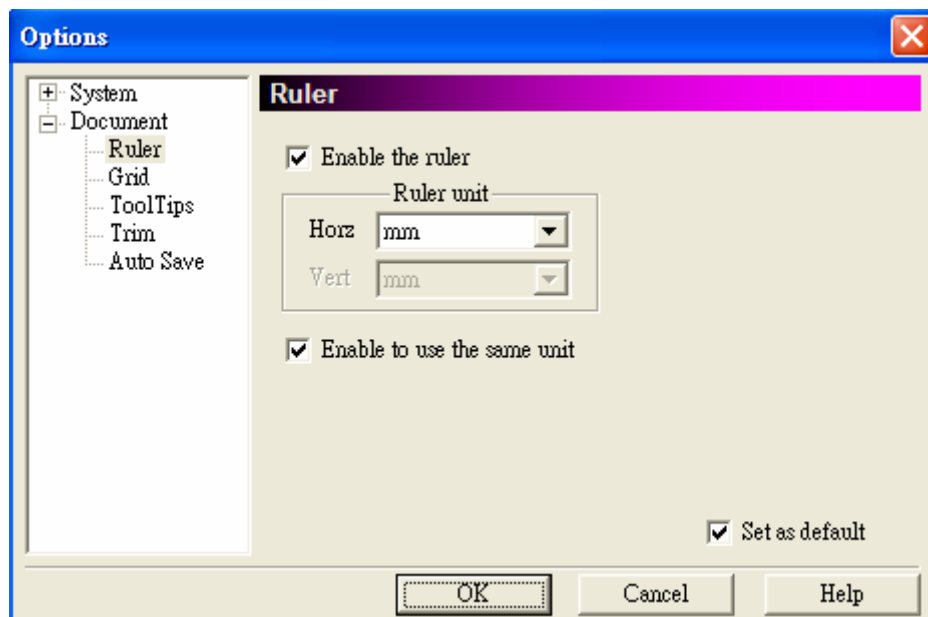

Use this function can help user realize the actual size of the object.

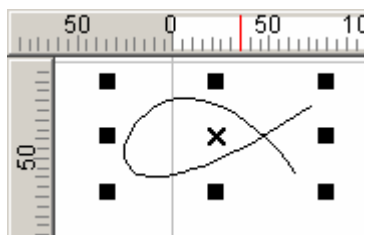

4.7.14.3 Grid / Grid Lock / Grid Parameter

The grid looks like below:

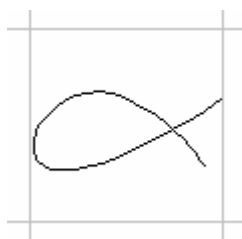

This grid function is used to help users realize the actual size of the object. When grid lock function is enabled, the coordinate value of objects will be locked to the grid when you move them.

The grid parameter setting is as below:

MarkingMate

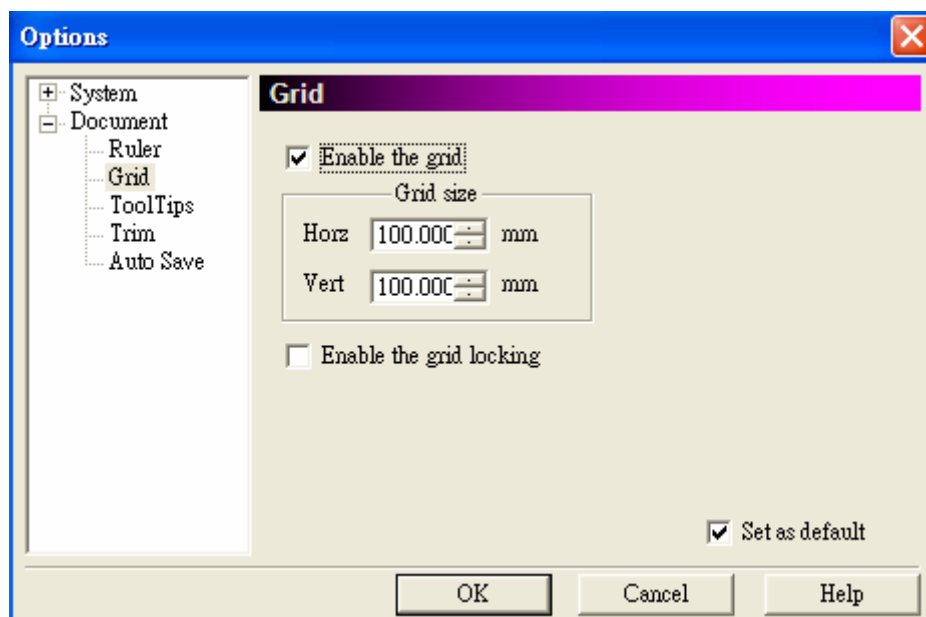

4.7.15 Zoom In

Enlarge a specific area

Tool Box : 

4.7.16 Zoom Out

Shrink a specific area

Tool Box : 

4.7.17 Zoom Previous

Go back to the previous view

Tool Box : 

4.7.18 Zoom All

Show the whole Work Area

Tool Box : 

4.7.19 Zoom Extend

Show all graphics in the Work Area

Tool Box : 

4.7.20 Show Hatch Line

MarkingMate

The function is to show the laser proceeding path when the object is filled. If this function is disabled, it looks like the left figure; while the function is enabled and the pitch of the fill parameter is set as 0.5, it looks like the right figure. (Please note that if the pitch is too small, there will be no differences between these two figures.)

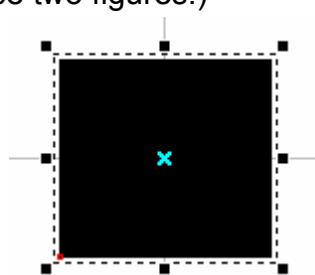

Without Hatch Line

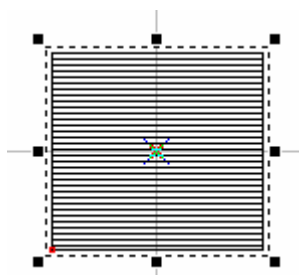

Show Hatch Line

MarkingMate

4.8 Window Menu

“Window” menu offers the following functions:

New	Create new window
Cascade	Allow all open windows overlapping
Tile	Show all open windows without overlapping
Arrange	Rearrange the windows
Close All	Close all windows

New

Create new window. Use this function to create a new window; the content of the new window will be the same with the one you was using. You can create multiple windows to view the different parts of your content. The modifications in any one of the window will also be displayed in the other windows.

Cascade

Allow all open windows overlapping as below:

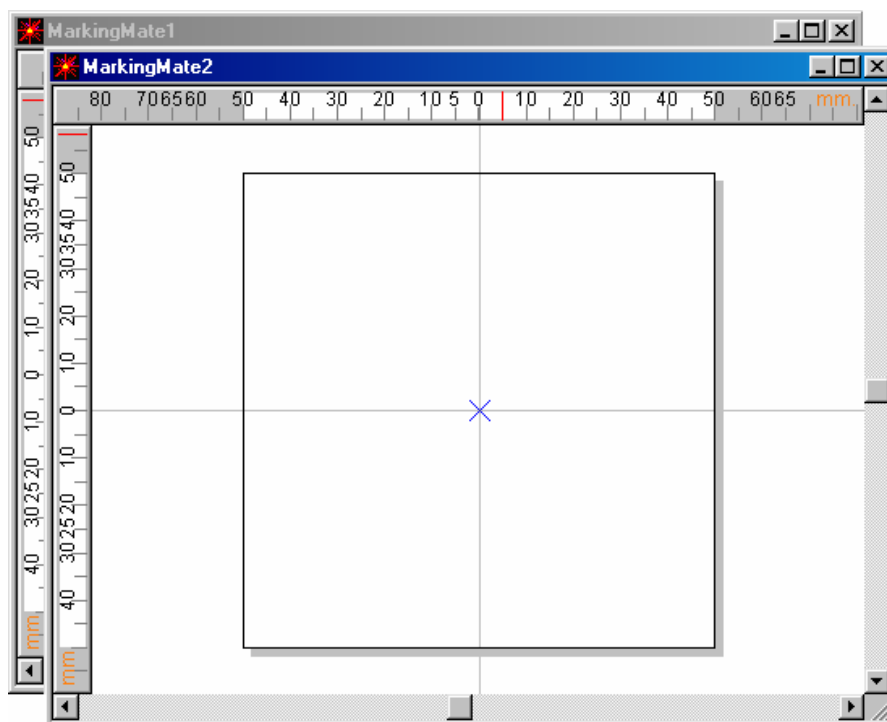

MarkingMate

Tile

Show all open windows without overlapping as below:

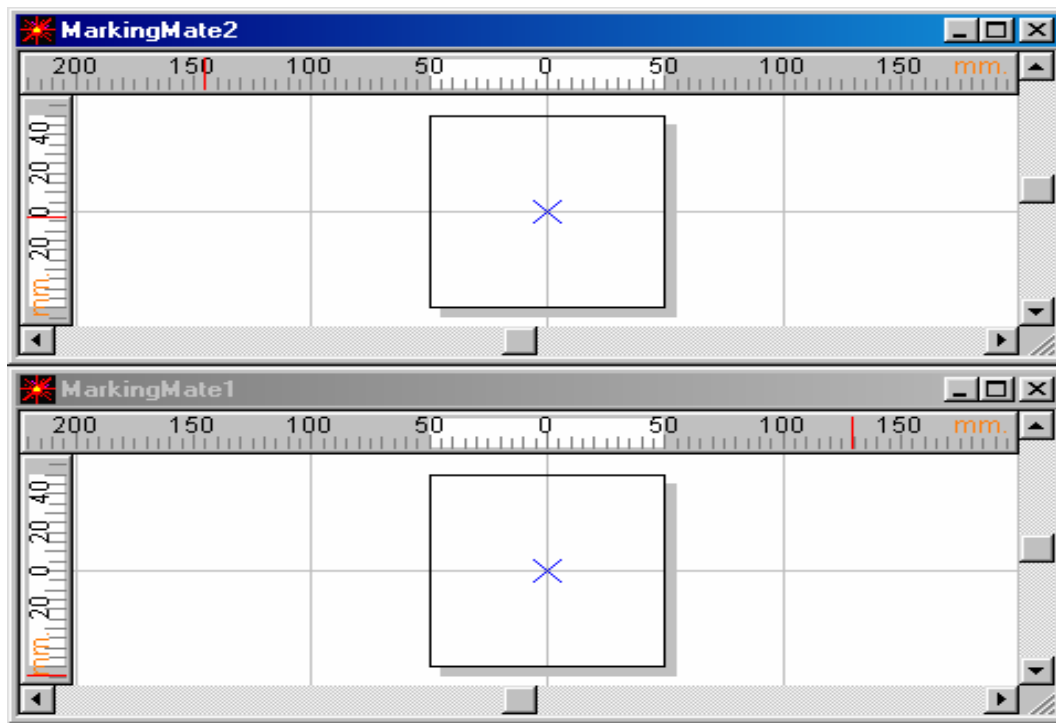

Arrange

Rearrange the windows. The shrink window will be list in the bottom as below:



Close All

Close all opened windows.

MarkingMate

4.9 Help Menu

“**Help**” menu will assist you to use this software

Help Topic The related information of the software

About MarkingMate The version information of the software

Help Topic

Click the Help Topic to search all information you need about this software

About MarkingMate



Chapter 5 Objects

The function for users to draw graphics, texts, and barcodes are so-called “Object Function”. These functions include dot, line, arc, circle, rectangle, curve, curve brush, text, arc text, 1D barcode, and 2D barcode. Whatever an object being selected, its related property table will be displayed for setting.

Besides, click the right button of mouse after selecting an object will display a popup menu providing the normal use functions and additional functions. For example, select a curve, click right mouse button, a function of edit vertex will be added in the popup menu.

Select the Curve object.

The property table of the Curve object will be displayed as the left side of the picture below.

Click the mouse right button will see the popup menu include the “Add Vertex” function.

5.1 Common Settings

This section will discuss the common setting page of the Property Table that includes Frame/Fill, Output Parameter, CAM Parameter, and the Popup Menu.

5.1.1 Property Table

When an object in the Work Area being selected, the property table of this object will be displayed. Users can set up some marking related parameters over the dialogue box; mainly include the object’s frame/fill, marking parameter, and delay.

Frame/Fill	Adjust the color of the border and interior shading of a selected object.
Mark Parameter	This menu in the Property Table will allow you to edit the assigned speed, power, and frequency output of the laser machine.
Delay	Setting some parameters about marking speed and quality.

(Please refer to section 6.2 Mark Parameter)

MarkingMate

5.1.2 Popup Menu

Select a general object and click the right button of the mouse, you will see a popup menu as below (select different object will see different popup menu):

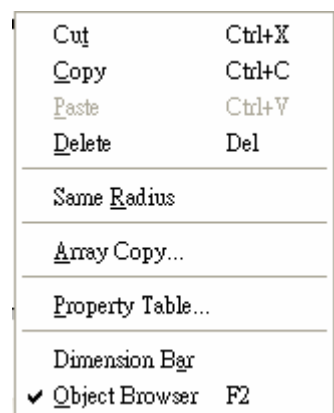

Cut	Remove selected data and store it in the clipboard for future use	Refer to section 4.2.3
Copy	Duplicate selected data and store it in the clipboard for future use	Refer to section 4.2.4
Paste	Attach data from the clipboard to the current document	Refer to section 4.2.5
Delete	Delete and remove the selected data	Refer to section 4.2.6
Same Radius	Make the circle become the same radius	Refer to section 4.3.4
Array Copy	Execute the array copy function	Refer to section 6.2.4
Property Table	Show the Property Table of the object	Refer to section 6.2
Dimension Bar	Enable/disable Dimension bar	Refer to section 4.7.1.7
Object Browser	Enable/disable Object Browser	Refer to section 4.7.1.5

5.2 Create Objects

Regarding how to create objects like a vertex, line, arc, circle, rectangle, curve, curve brush, text, arc text, 1D barcode, or 2D barcode, **please refer to section 4.3.2 to section 4.3.11.**

Line	Inserts straight lines from point-to-point-to-point	Refer to section 4.3.2
Arc	Creates arcs, circles, and spirals	Refer to section 4.3.3
Circle	Creates circles and ovals	Refer to section 4.3.4
Rectangle	Creates squares and rectangles	Refer to section 4.3.5
Curve	Creates a curve using three points of reference	Refer to section 4.3.6
Curve Brush	Draws freehand lines by the mouse	Refer to section 4.3.7
Text	Inserts text in the Work Area	Refer to section 4.3.8
Arc Text	Inserts text based on an arc	Refer to section 4.3.9
1D Barcode	Creates 1D barcode	Refer to section 4.3.10
2D Barcode	Creates 2D barcode	Refer to section 4.3.11

Chapter 6 Property Table

All objects created or imported on the Work Area have their own unique sets of properties. These properties define how each specific object or groups of objects are displayed on the Work Area or how they being marked by MarkingMate.

To display the properties of an object or a group, simply highlight it and the specific property details should reveal themselves on the Property Table. If the Property Table is not currently active, press the right mouse button and click on Property Table's editing capabilities.

NOTE: Any modifying of the property will be effective only if you press "Apply" button. You can also click "Apply All" after all property pages being finished to make sure every change are effective.

Below will see the more detail description of the four portions of the Property Table:

System-related	Settings for all parameters needed for the system.
Mark-related	Settings for all parameters needed for a specific object.
Object-related	Settings for all general properties of the objects.
Layer-related	Settings for the layer-related parameters.

MarkingMate

6.1 System-related

When there is no object in the Work Area being selected, it means the system object be selected in concept. Therefore the system property page will appear at this time. You are able to set the characteristics of laser machine such as lens dimension, curve correction, and testing.

6.1.1 Lens

Lens means f-theta lens, lens' dimension will effect the work area; if it is not properly adjusted will cause center drifting and distortion. To mark an object as perfect as your design in computer, you have to adjust the parameters carefully.

Working Area – The software system uses voltage signals to control GALVO motor, it is unable to know how big the working area is unless user input the correct value. If the work area is 100mm, user should enter 100mm over here. If it is mistaken to be 50mm, the finished goods will be doubly enlarged; on the other hand, if it is mistaken to be 200mm, the finished goods will become half size.

Offset – Normally set X=0 and Y=0 will be fine. If can not put the working piece in a ideal position, you can modify the design or change the offset value to fix the position. If the mark position is right shift 5mm, you can enter -5mm in the X column. So are the others.

Scale –If the dimension of drawing (theoretical size) and marking result (real size) are different, you can input the scale percentage of X and Y to fix it. The unit of scale is percentage which stands for (*theoretical size / real size * 100*). So if the real size is smaller, this value should be larger than 100; on the contrary the value should be smaller than 100.

Rotate –Normally, set Angle=0, CX=0, and CY=0 will be fine. If the working pieces can not put in a ideal position, you can modify the design or input suitable values in these fields to fix it.

Power Test	Motor Setup	Graph Setup
System	Lens	Driver
		Global
Working Area:		100.000 mm
Offset		Scale
X:	0.000 mm	X: 100.000 %
Y:	0.000 mm	Y: 100.000 %
Rotate		
Angle:	0.000	CX: 0.000
		CY: 0.000
<input type="checkbox"/> X Reverse	<input type="checkbox"/> Y Reverse	<input type="checkbox"/> XY Exchange
Correction		
X:	0.0000	X: 0.0000
Y:	0.0000	Y: 0.0000
Default		Manager
Apply All		

MarkingMate

X Reverse/ Y Reverse/ XY Exchange

It is possible that user has to adjust the coordinates of the Work Area for his local condition. Our system provides X reverse, Y reverse, and XY exchange for users to choose or combine as their needs.



Correction



When there is barrel distortion, trapezoid distortion, or parallelogram distortion happened, enter the suitable X/Y values to do the correction.

Barrel Correction

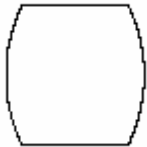
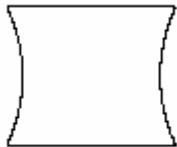
A normal f-Theta Lens system will result in barrel distortion because its naturals. The system initial value here is (0.000), if the figure become protuberant in X-axis, the X value will need to be increased like 0.002; while if now it become indentation, the X value will have to be reduced to as 0.0014. Keep adjusting the value until it is acceptable.

Input a square, the output become as below:

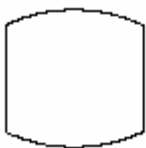
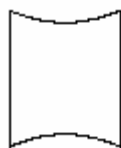

Original		
Marking Results		
Solutions	Enlarge the X value of  field	Reduce the X value of  field



Original		
Marking Results		
Solutions	Enlarge the Y value of  field	Reduce the Y value of  field

Trapezoid Correction

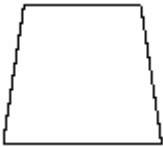
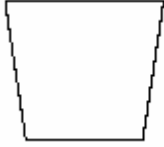
Input a square, the output become as below:



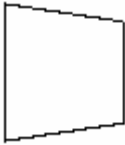
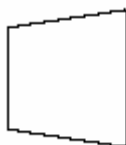

MarkingMate

Original		
M a r k Results		
Solutions	Enlarge the X value of  field	Reduce the X value of  field

Original		
M a r k Results		
Solutions	Enlarge the Y value of  field	Reduce the Y value of  field



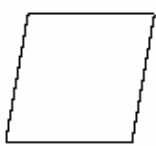

Parallelogram Correction

Input a square, the output become as below:

Original		
M a r k Results		
Solutions	Enlarge the X value of  field	Reduce the X value of  field

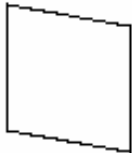
Original		
----------	---	--

MarkingMate

Marking Results		
Solutions	Enlarge the Y value of  field	Enlarge the Y value of  field

Lens Name

The name of the lens parameters. If you want to add other lens parameters, just press the “Manager” button, the Lens Setup page will be displayed as below:

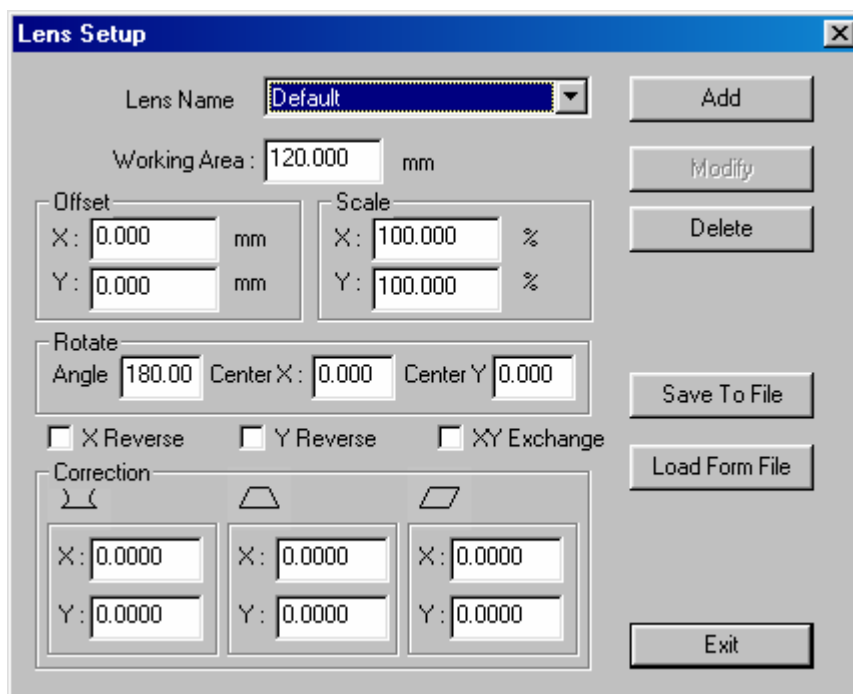

Save To File – Allow users to save the lens parameters as a file named of *.len

MarkingMate

6.1.2 Driver

Driver

Here is the information of driver name and version.

Maximum Speed

This editing function is used to adjust the maximum speed of the GALVO. The default maximum speed is 3000 mm/sec.

I/O Test

Press the button of I/O Test, a dialogue box as below will be displayed to monitor the input and output status.

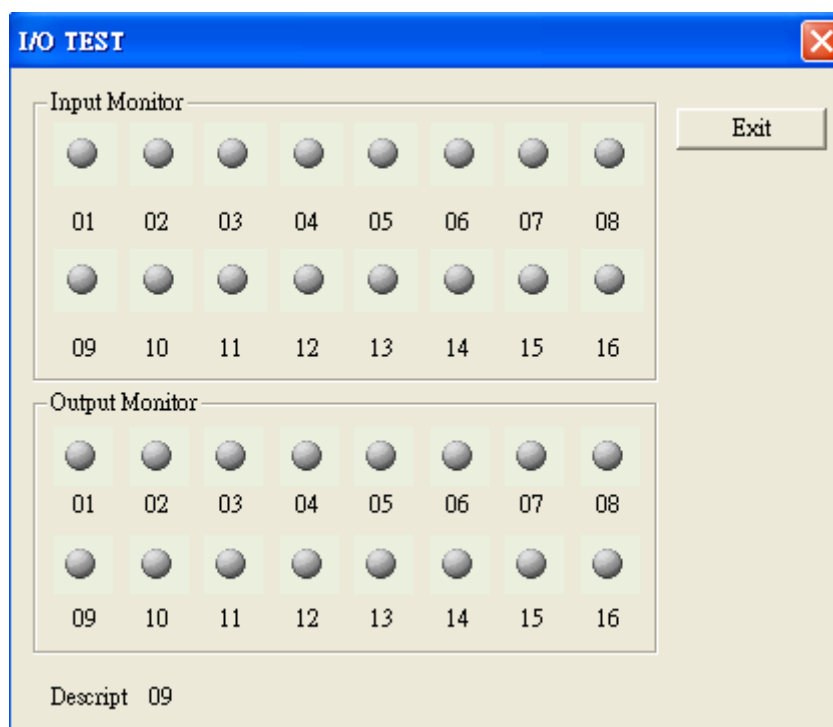
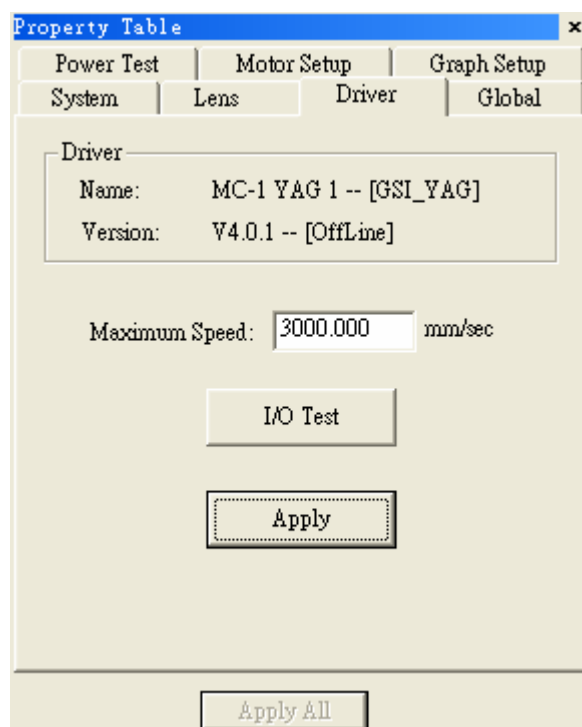

MarkingMate

6.1.3 Global

Marking Maximum: Set up desired total working times. This function will allow you to avoid the unwilling excess working pieces.

Marking Amount: It enables you to take down how many work pieces you have already done.

Trigger Max: Specify the counts of marking for trigger. Show message for trigger.

Show MSG: If checked, the system will show message while the marking amount reaching Trigger Max value.

Comment: Input a summary of the file.

Mark On Fly: It enables you to mark while the working pieces are moving. You can choose to use this function on X or Y Axis.

X/Y Encoder (no-checked):

Speed: speed of conveyer.

Delay: delay a giving count pulse then start marking.

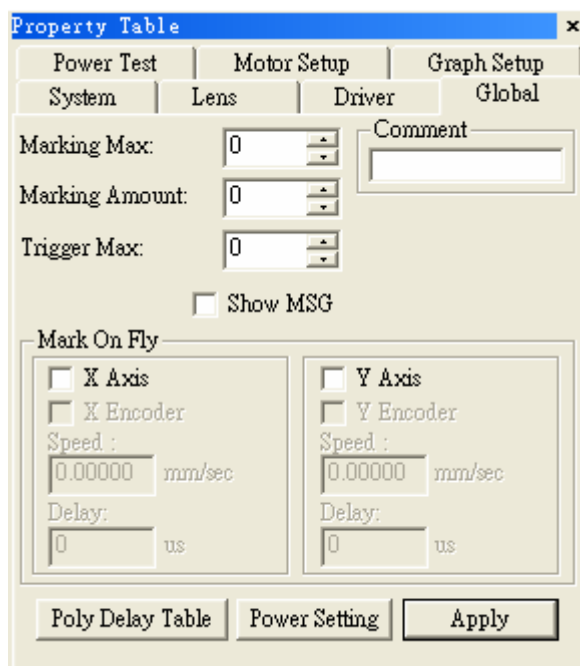

X/Y Encoder (checked):

Factor: the value of conveyer moving per encoder count.

Delay: delay a giving count pulse then start marking.

Poly Delay Table:

Press the “Poly Delay Table” button will show a dialogue box as below:

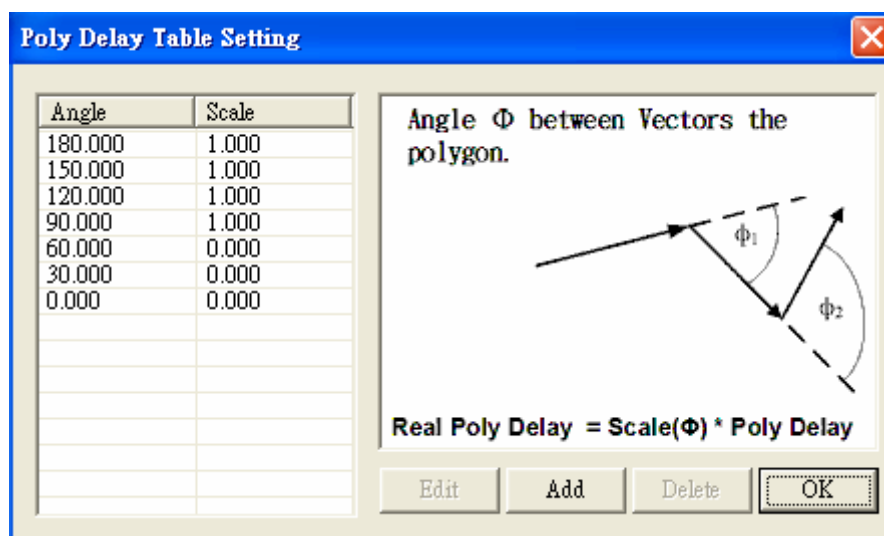

The value of Angle and Scale will effect the Poly Delay time in the

MarkingMate

setting of Delay page of Property Table in section 6.2.3. IT follows the rule as description below:

For more accurately control the marking quality of the corner or the cross of two line segments, the system offers another method. Users can go to the directory of C:\Program Files\MarkingMate, open the config.ini file, change the setting of "VariablePolyDelay=0" to "VariablePolyDelay=1", save the file and restart the program.

If the setting is "VariablePolyDelay=0" that means no matter how big the cross angle is the Poly Delay follow the delay parameter setting. And if change to "VariablePolyDelay=1", the system will change the Poly Delay time in accordance with angle, its calculation rule is:

$$\text{DelayTime}(\phi) = \text{scale}(\phi) \cdot (\text{Poly Delay})$$

Among the above formula, $\text{scale}(\phi)$ is a ratio value between 0 and 2. Please note that ϕ is a supplementary angle of an included angle, and it is calculated as below:

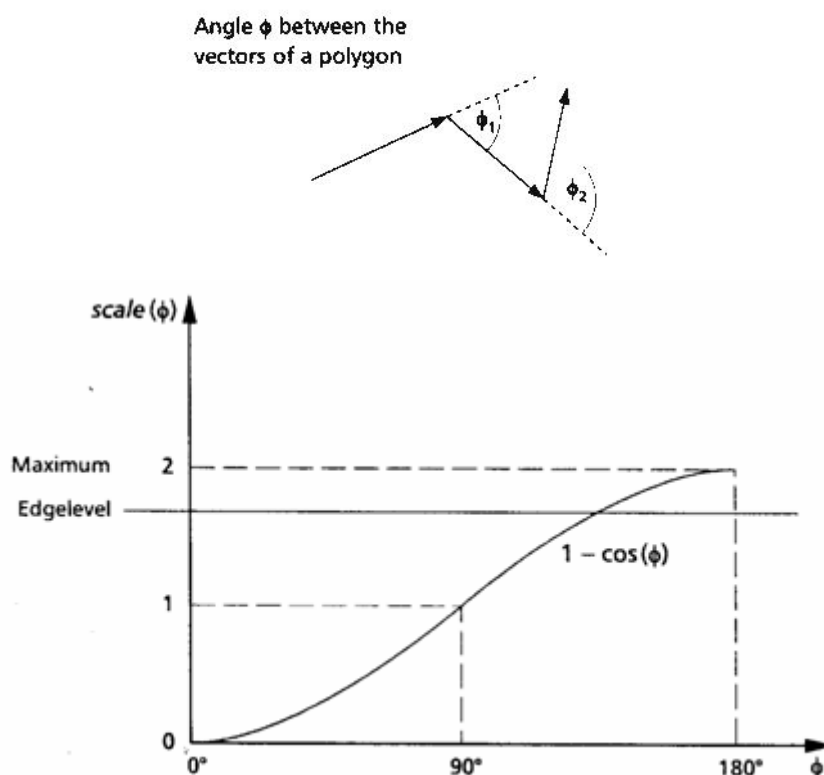

Press "Add" button will display the dialogue box of "Poly Delay Table Editor" as below for you to enter the new value of angle and scale.

MarkingMate

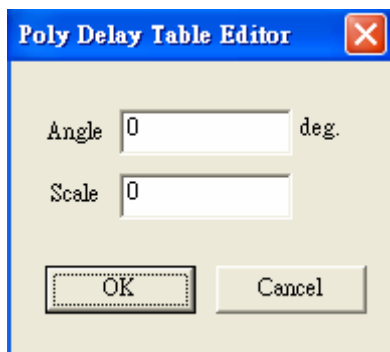

Press the **“Power Setting”** button will show the “Power Setting” dialogue box as below. The page allows you to set up the time for full power variation and delay time for being steady. Moreover, you can set how much time to enter power saving mode and the power percentage during idle time.

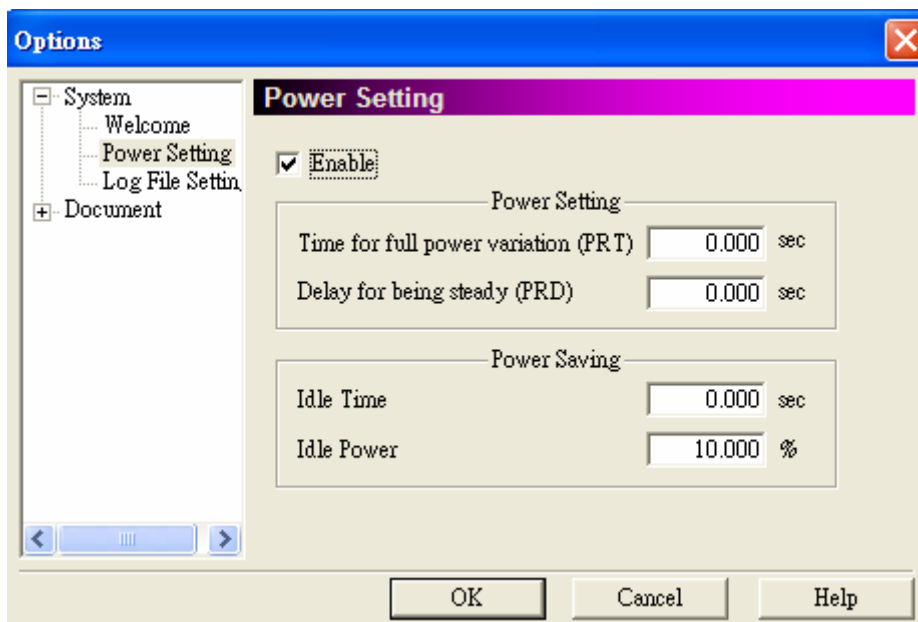

MarkingMate

6.1.4 Power Test

This function will enable you to conduct a laser test. You can adjust the power, duration and frequency of the laser pulse. Laser tests are useful to identify which settings are best for different materials.

NOTE: Applying too much power may engrave or cut the materials too deeply or cause unwanted burning. Certain plastics can easily be marked using a low power setting.

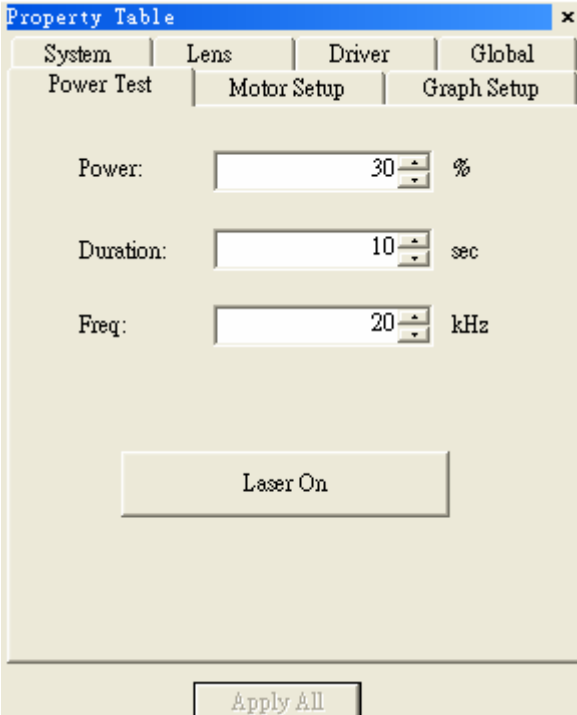

The screenshot shows a software window titled "Property Table" with a close button (X) in the top right corner. The window is divided into several sections. At the top, there are four tabs: "System", "Lens", "Driver", and "Global". Below these, there are three sub-sections: "Power Test", "Motor Setup", and "Graph Setup". The "Power Test" section contains three rows of settings, each with a label, a numeric input field, and a unit:

System	Lens	Driver	Global
Power Test	Motor Setup	Graph Setup	
Power:	<input type="text" value="30"/>	%	
Duration:	<input type="text" value="10"/>	sec	
Freq:	<input type="text" value="20"/>	kHz	

Below the settings is a large button labeled "Laser On". At the bottom of the window is a button labeled "Apply All".

MarkingMate

6.1.5 Motor Setup (optional)

This marking software can be set up to mark materials that are rounded not flat. For example, if you want to mark a serial number on a bowling ball, you would need to enable the Rotary Marking function and edit the levels to accommodate the radius of the portion to be engraved and the angle of the round object. For larger marking areas, the round object would need to be marked, turned slightly, and then marked again. The turning of the object can be done by hand or by an auxiliary machine.

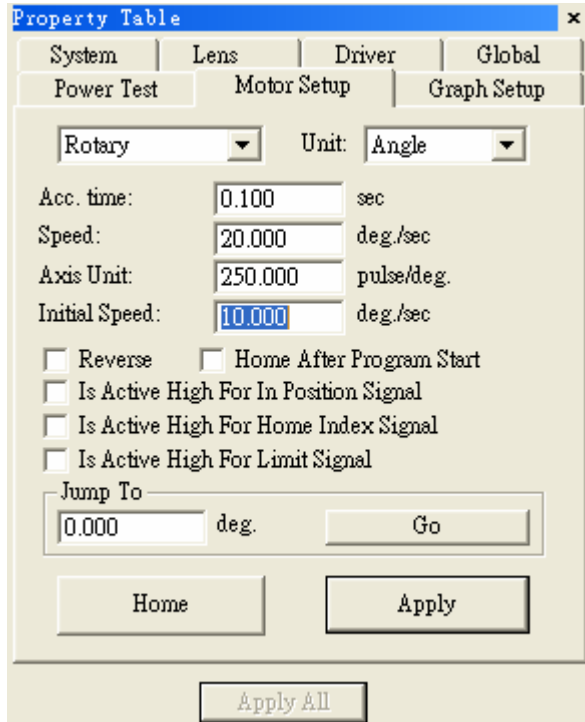

If a machine is used to turn the object, be sure to insert a Digital Out control object to active the machine.

Selection: Rotary

Unit: Length or Angle

Acc. Time: the accelerate speed of the motor

Speed: the rotary speed of the rotary axis

Axis Unit: the rotate pulse for each rotating

Initial Speed: the initial velocity of motor

Reverse: The motor turns in the reverse direction

Homing After Program Start: when it is checked, the program will start from Home

Active High For In Position Signal: if checked, the In Position signal of motor is active high

Active High For Home Index Signal: if checked, the Home Index signal of motor is active high

Active High For Limit Signal: if checked, the Limit signal of motor is active high

Jump to: Move directly to the position you assigned

Home: execute Home action

MarkingMate

6.1.6 Graph Setup (optional)

Rotary Direction

In the direction of X Axis –
The rotary is set in the direction of X Axis.

In the direction of Y Axis –
The rotary is set in the direction of Y Axis.

Exchange – If the rotary is not in the expected direction and unable to change by hardware, then you can check this checkbox.

Method of Mark End

Reverse Direction – Back to the origin in reverse direction

Shortest Path – Back to the origin in the shortest path

Reset As Origin – The end-point being reset as origin

Forward Direction – Back to the origin in the forward direction

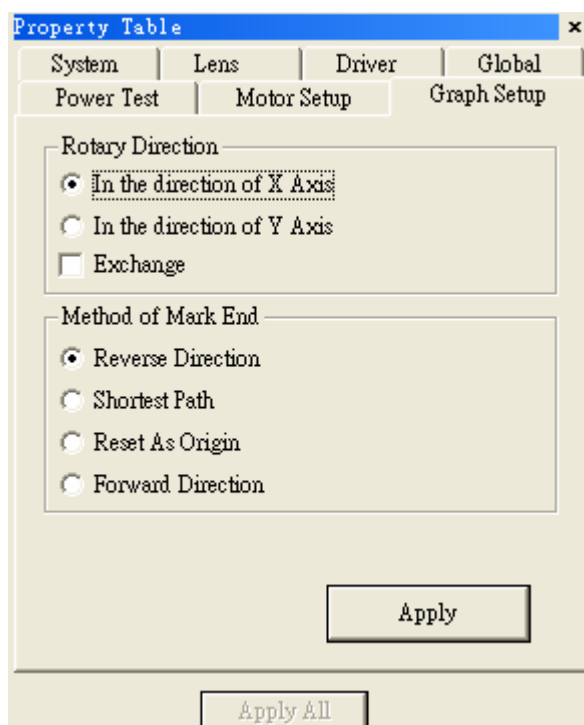

6.1.7 System

If no object being selected, will display the system page.

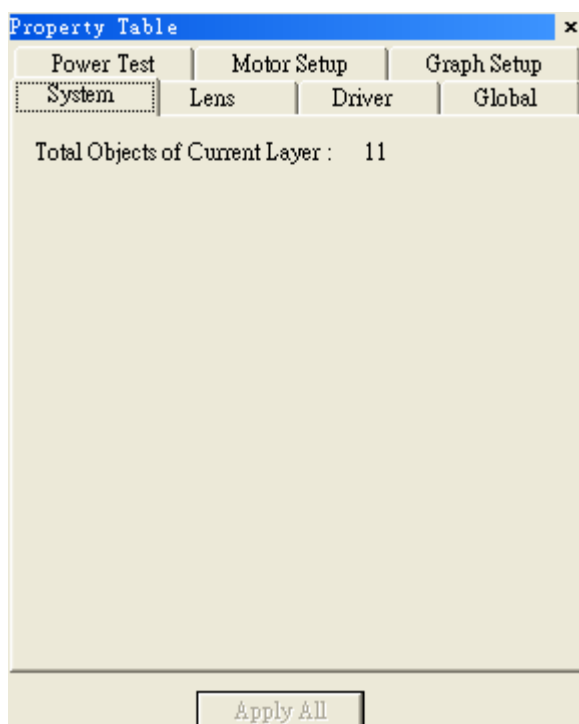

MarkingMate

6.2 Mark-related

When an object in the Work Area being selected, the property table of this object will be displayed. Users can set up some marking related parameters over the dialogue box; mainly include the object's frame/fill, mark parameter, delay, array copy, and motion setup.

6.2.1 Mark Parameter

This menu in the Property Table will allow you to edit the assigned speed, power, and frequency output of the laser machine. The slower the speed and more prominent the marking will be. Different speed, power, frequencies and materials will produce different results. Different objects in the Work Area may be assigned with different speed, power, and frequency settings. We offer multiple Mark Parameter from 1 Pass to maximum 5 Passes.

Speed: Marking speed.

This value can't be faster than the system's maximum speed.

Power: current percentage (in YAG) or percentage of PWM high signal (in CO2)

Freq: Laser trigger cycle (this item is useless in some CO2 system that controlled by voltage)

Times: When select Single Pass, Times value is able to input how many times for marking repeat. If Times is 0, means no marking.

Spot delay: the mark time for each pixel of the image object. If this value is 0.5ms that means the spot will mark for 0.5ms.

Pulse Width (YAG)

Pulse width for YAG driver only.

Wobble

Mark by spiral type as below, this way can make the line segment become thicker.

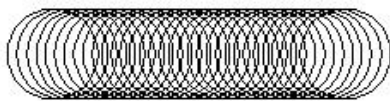

Thick The diameter of the circle

Freq. When speed become quicker, and the frequency higher, the line segment will be thicker.

MarkingMate

6.2.2 Frame/Fill

Adjust the color of the border and interior shading of a selected object. To fill an enclosed area simply select the object and select Fill and Apply.

Fill Param: when the object is filled by Hatch mode, the below parameters are able to be modified

Style: there are three modes for hatch can be selected:



Loops: draw some circles inside the object first and then fill the object by the above selected hatch mode.

Border: the distance between hatch line and the frame

Pitch: the spacing between each hatch line

Times: process frequency

Angle Start: the first hatch angle

Angle Step: each angle step for hatch

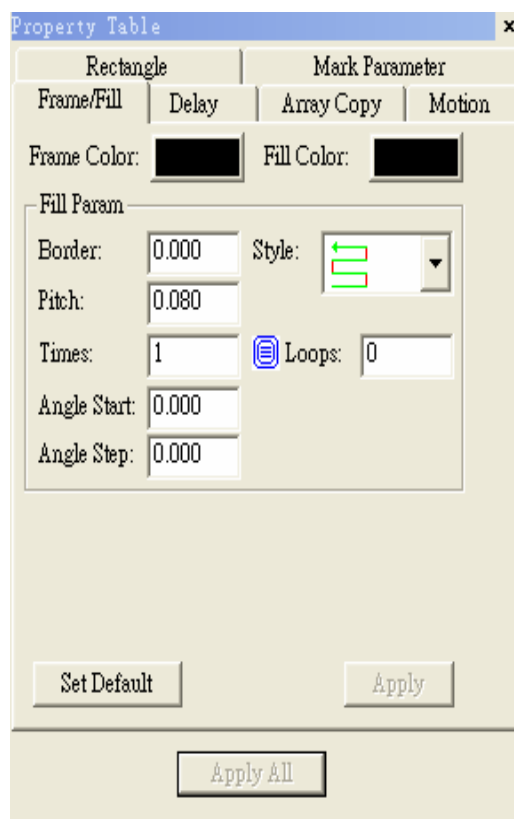

* If choose  mode, then you can only set up pitch for the fill parameter.

6.2.3 Delay

Setting some parameters related to marking speed and quality. The parameter will be saved in the file.

A dialogue frame as right-hand will appear after executing this function.

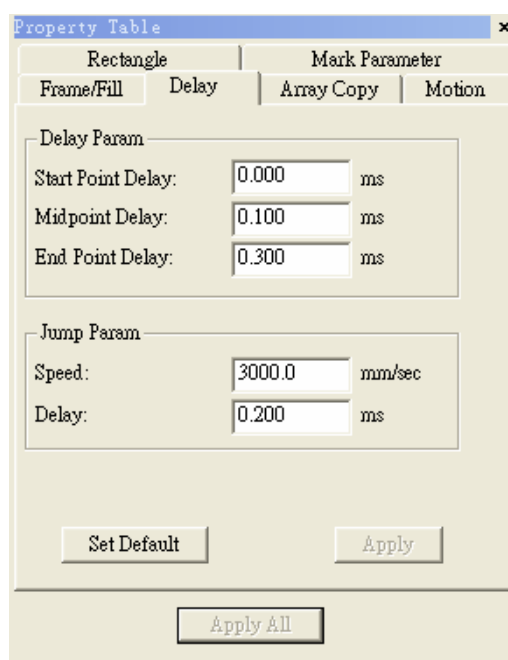

MarkingMate

(1) Start Point Delay:

The time difference between start laser order and laser hit time. Generally, the default value is 0; however, some other laser marking machines may take some time, so this value is adjustable to get the highest marking quality.

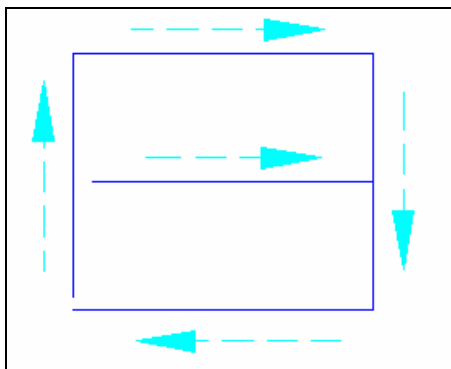

Figure 1. : The delay time is too short that caused some line segments being unmarked.

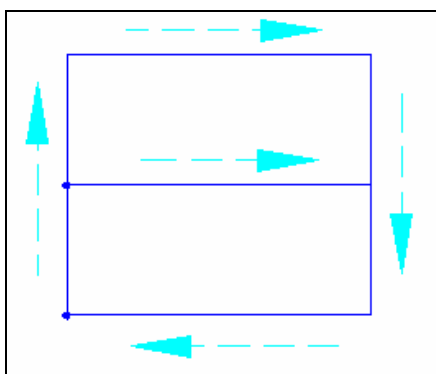

Figure 2. : The delay time is too long that caused some line segments being over marked.

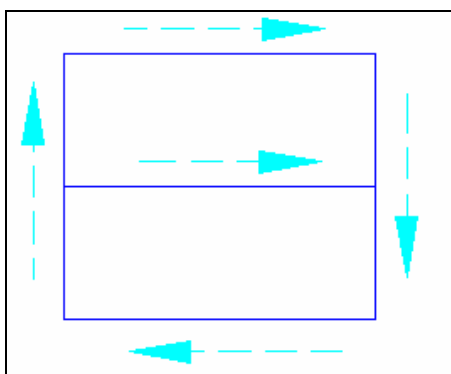

Figure 3. : When the delay time is proper, the beginning of the line segment will be smooth going.

MarkingMate

(2) End Point Delay:

The time value may effects the accuracy on the ending of the line segments.

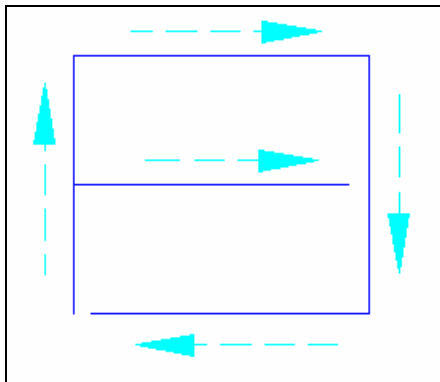

Figure 1. : When the delay ending time is too short, the ending of line segments will be unmarked.

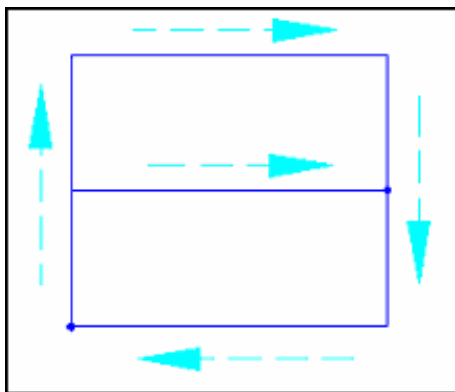

Figure 2. : When the delay ending time is too long, the ending of line segments will be over marked.

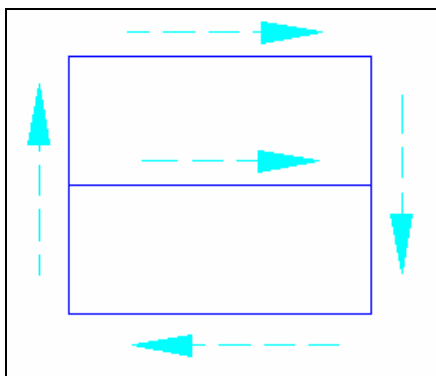

Figure 3. : When the delay ending time is proper, the ending of line segment is smooth going.

MarkingMate

(3) Poly Delay:

The time value may effects the marking quality of the corner or the cross of two line segments

For more accurately control the marking quality of the corner or the cross of two line segments, the system offers another method. Users can go to the directory of C:\Program Files\MarkingMate, open the config.ini file, change the setting of "VariablePolyDelay=0" to "VariablePolyDelay=1", save the file and restart the program.

If the setting is "VariablePolyDelay=0" that means no matter how big the cross angle is the Poly Delay follow the delay parameter setting. And if change to "VariablePolyDelay=1", the system will change the Poly Delay time in accordance with angle, its calculation rule is:

$$\text{DelayTime}(\phi) = \text{scale}(\phi) \cdot (\text{Poly Delay})$$

Among the above formula, $\text{scale}(\phi)$ is a ratio value between 0 and 2. Please note that ϕ is a supplementary angle of an included angle, and it is calculated as below:

Angle ϕ between the vectors of a polygon

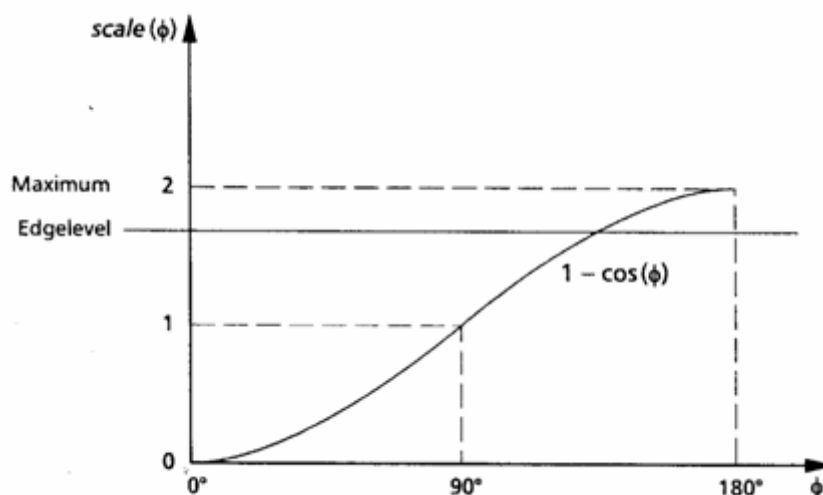
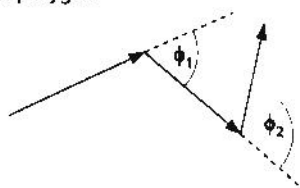

MarkingMate

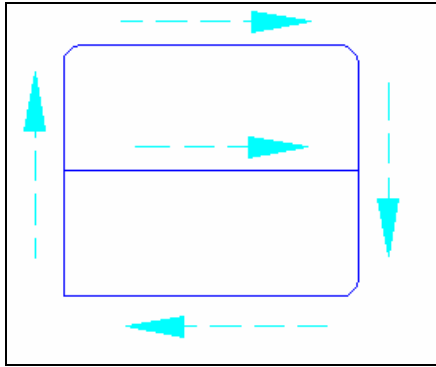

Figure 1. : When the suspending time is too short, the corner will become an arc.

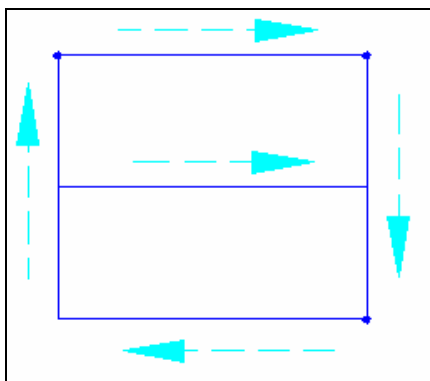

Figure 2. : When the suspending time is too long, the corner may be over marked.

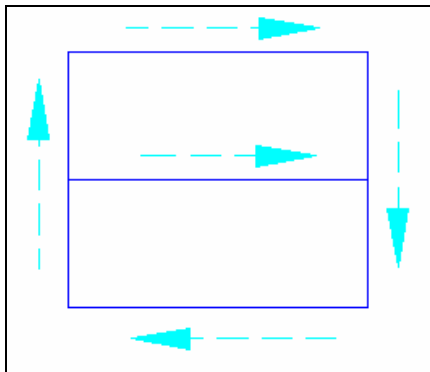

Figure 3. : When the suspending time is proper, the corner is smooth going.

MarkingMate

6.2.4 Array Copy

Array Copy Mode: By Matrix

This function will allow you to copy an individual object into an ordered series. Begin with a selected object in the lower left corner of the Work Area. Click on By Matrix and select the number of repeated objects you wish to include in a select amount of rows and columns. You also must adjust the vertical and horizontal gap between the objects, if the gap is not wide enough, the objects will overlap.

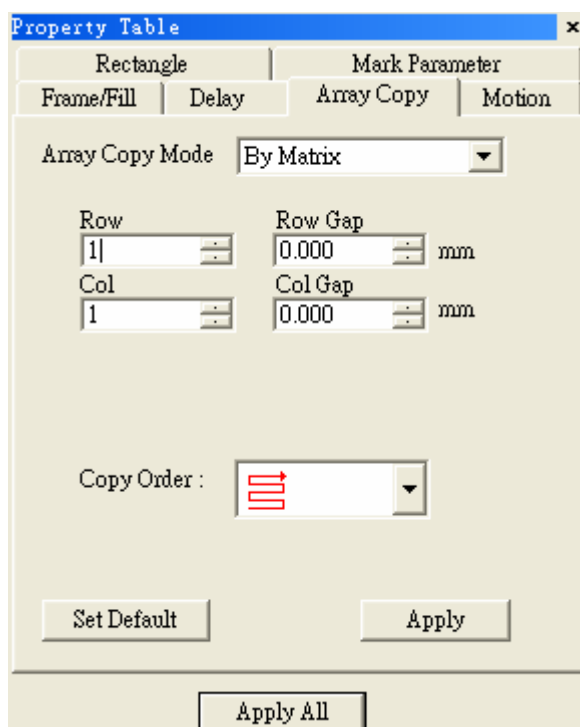

Array Copy Mode: By Circle

This variation of the Circle Copy allows you to arrange a series of copied objects in a circle. This function allows you to adjust the following:

Circle Radius – edit the size of the circle

Object Counts – edit the number of copied objects

Object Start Angle – adjust the starting point of the circle from 0-360 degrees

Object Angle Pitch – adjust the spacing between the copied objects

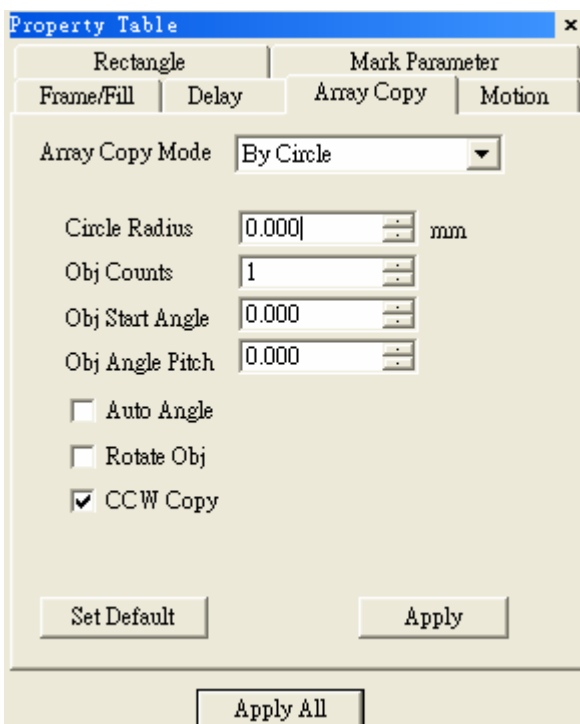

Auto Angle – automatically space the objects to complete one whole circle

Rotate Object – select between objects that remain vertical or ones that follow the baseline of the circle

CCW Copy – select between clockwise or counter-clockwise. This will affect the directional order of the copied objects.

MarkingMate

6.2.5 Motion (optional)

When a non-text object being selected, the Motion page of Property Table allows users to do the settings as below:

Enable

Allow users to enable or disable the rotary axis function.

Start Position

The start position of the rotary axis

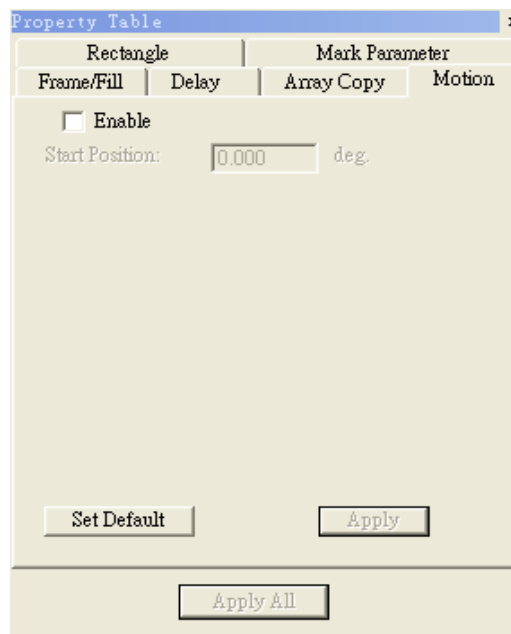

When a text object being selected, the Motion page of Property Table allows users to do more settings

Text option

Separate To Character

Separate the selected text to characters

Pitch

The distance between characters

Center – based on the center of the character

Edge – based on the edge of the character

Diameter – the diameter of the rotary axis

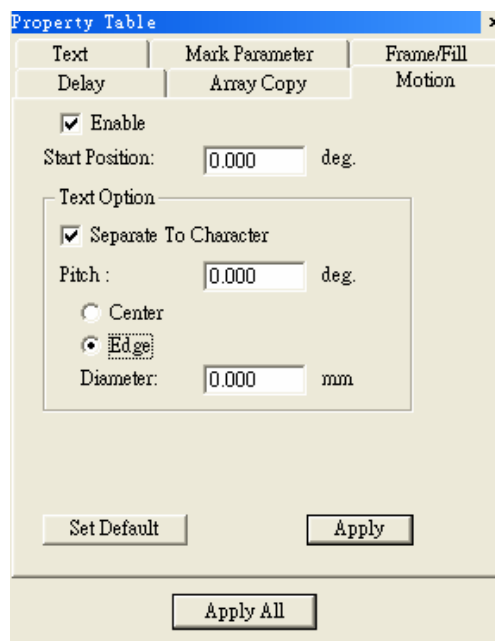

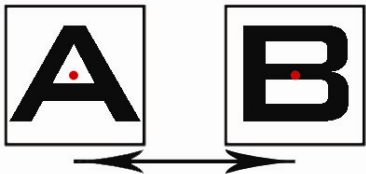
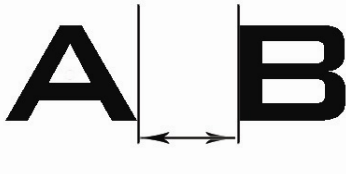
Center	Edge
	

MarkingMate

6.3 Object-related

When an object in Work Area being selected, the Property Table of this object will be displayed. Users are allowed to edit the parameters of this object over these pages such as curve, arc, circle, rectangle, 1D barcode, 2D barcode, image, text, arc text, and baseline.

6.3.1 Curve

This function applies to curves or other linear objects. Click on Closed Path to join the nearest ends of the curve or line. For example, if you create only 320° of a circle, the Closed Path function would automatically fill in the remaining 40°.



MarkingMate

6.3.2 Arc

Adjust the center position, radius, start dot and end dot position of the Arc.

Delay	Array Copy	Motion
Arc	Mark Parameter	Frame/Fill
Center		
X:	<input type="text" value="4.889"/>	mm Y: <input type="text" value="-0.556"/>
Radius		
X:	<input type="text" value="9.667"/>	mm Y: <input type="text" value="9.667"/>
<input checked="" type="checkbox"/> Same as X		
Start Dot		
X:	<input type="text" value="14.556"/>	mm Y: <input type="text" value="-0.667"/>
Start Angle:	<input type="text" value="359.341"/>	deg.
End Dot		
X:	<input type="text" value="-4.778"/>	mm Y: <input type="text" value="-0.444"/>
End Angle:	<input type="text" value="179.341"/>	deg.
<input type="button" value="Apply"/>		
<input type="button" value="Apply All"/>		

6.3.3 Circle

Adjust the Circle's center position and radius.

Delay	Array Copy	Motion
Circle	Mark Parameter	Frame/Fill
Center		
X:	<input type="text" value="-15.778"/>	mm Y: <input type="text" value="-18.333"/>
Radius		
X:	<input type="text" value="9.667"/>	mm Y: <input type="text" value="3.444"/>
<input type="checkbox"/> Same as X		
<input type="button" value="Apply"/>		
<input type="button" value="Apply All"/>		

MarkingMate

6.3.4 Rectangle

Adjust the round radius of the rectangle from 0% to 100%.

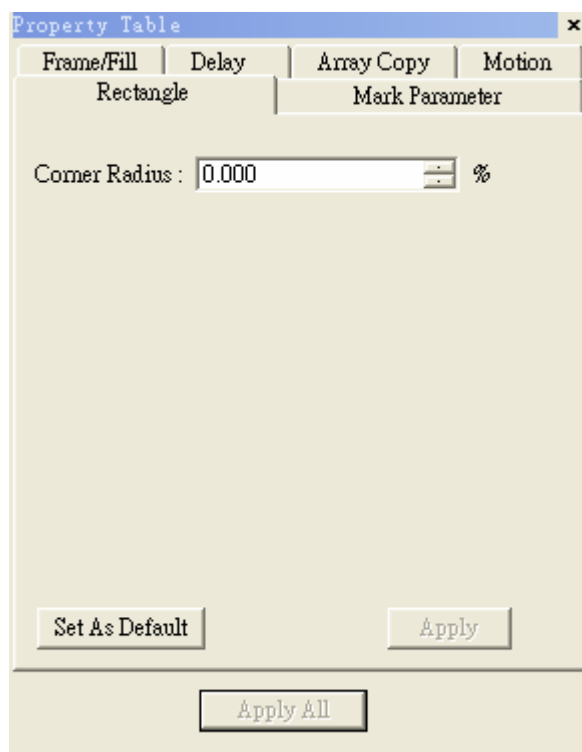

6.3.5 1D Barcode

Allow you to edit the properties of an existing 1D barcode

Code Type

Code 39, Code 128, Code 93, Code Bar, ITF, MSI Code, Us PosNet, UPC-A, UPC-E, EAN 8, EAN 13, UCC 128, EAN 128, FIM

Code Data

Input the code data here.

Show Text

Checked the box, the text content will be displayed under barcode.

Invert

When the background is black, you need to use this function.

EX: The barcode reader is not easy to read the barcode marked on black work piece, use invert function will make it more readable.

Auto Text

The barcode data will be changed as an auto text.

Check Digit

A check digit is calculated automatically and added.

A

The distance between laser spot center and the edge of barcode.

B

The space between the next two laser spots

MarkingMate

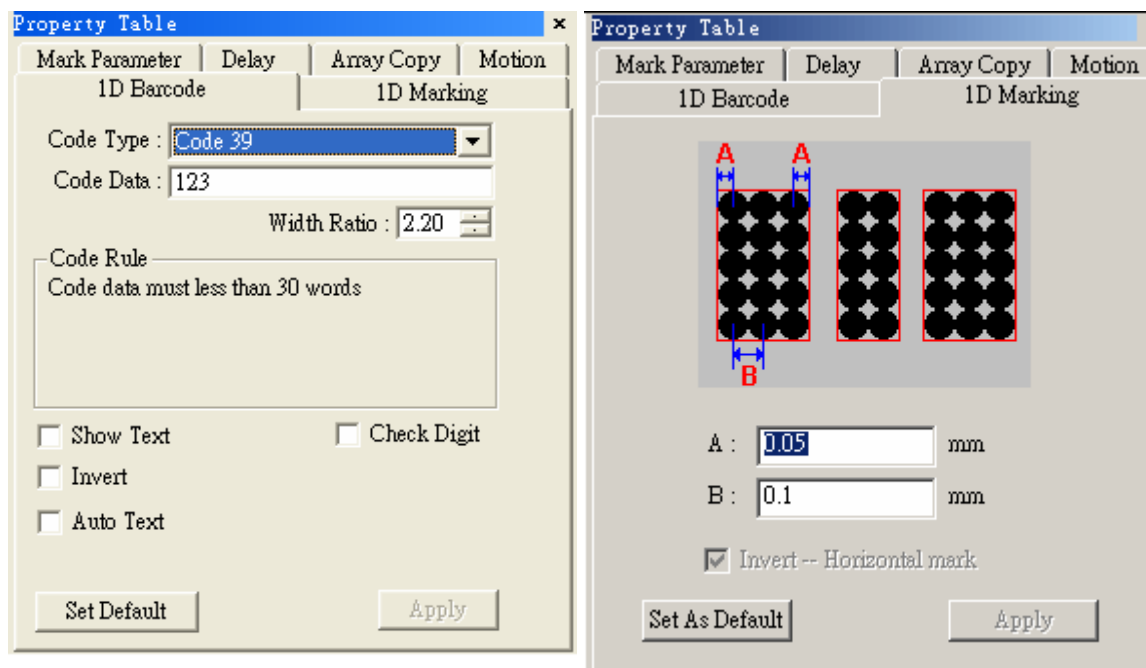

6.3.6 2D Barcode



Allow you to edit the properties of an existing 2D barcode on the Work Area

2D Barcode Type

ECC 000~140, ECC 200, PDF417, QR Code, and Maxi Code

Style

The barcode is divided into many cells, each cell has three style options as below:

Spot	Line	Rectangle
The spot can not be overlapped	Marked as lines	From outside to inside marked as rectangles
		

Spot Delay

The longer the spot delay, the mark effect will be stronger

MarkingMate

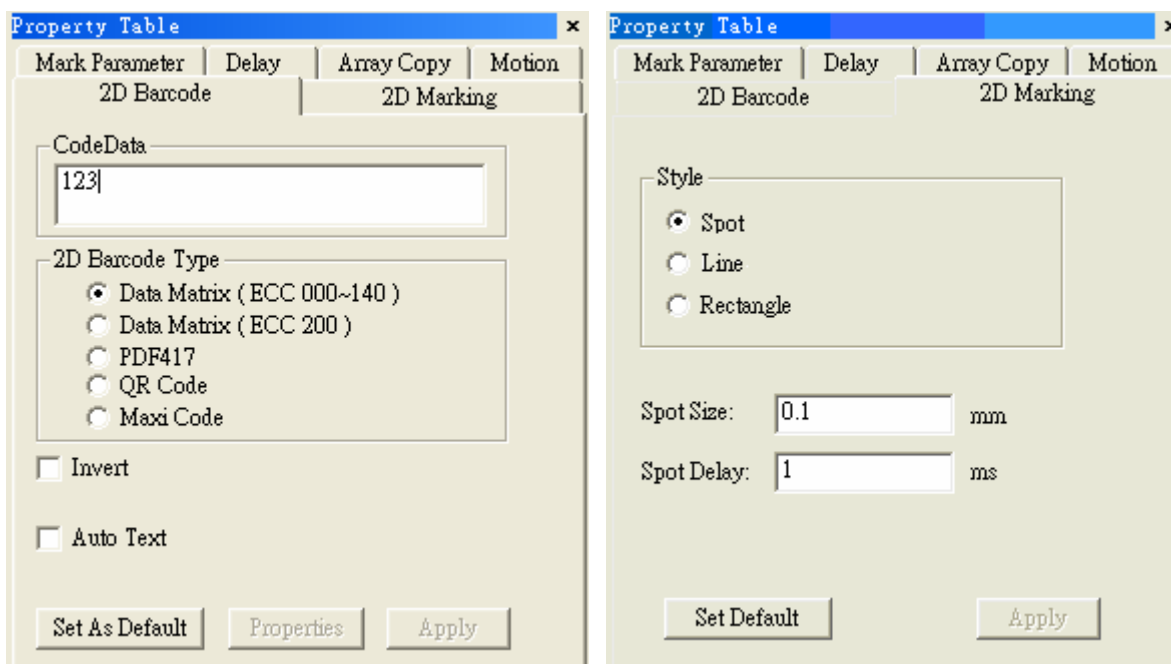

6.3.7 Image

Image properties setting

Resolution

The resolution of the image

Style

Pixel – Mark as pixels

Line – Mark as lines

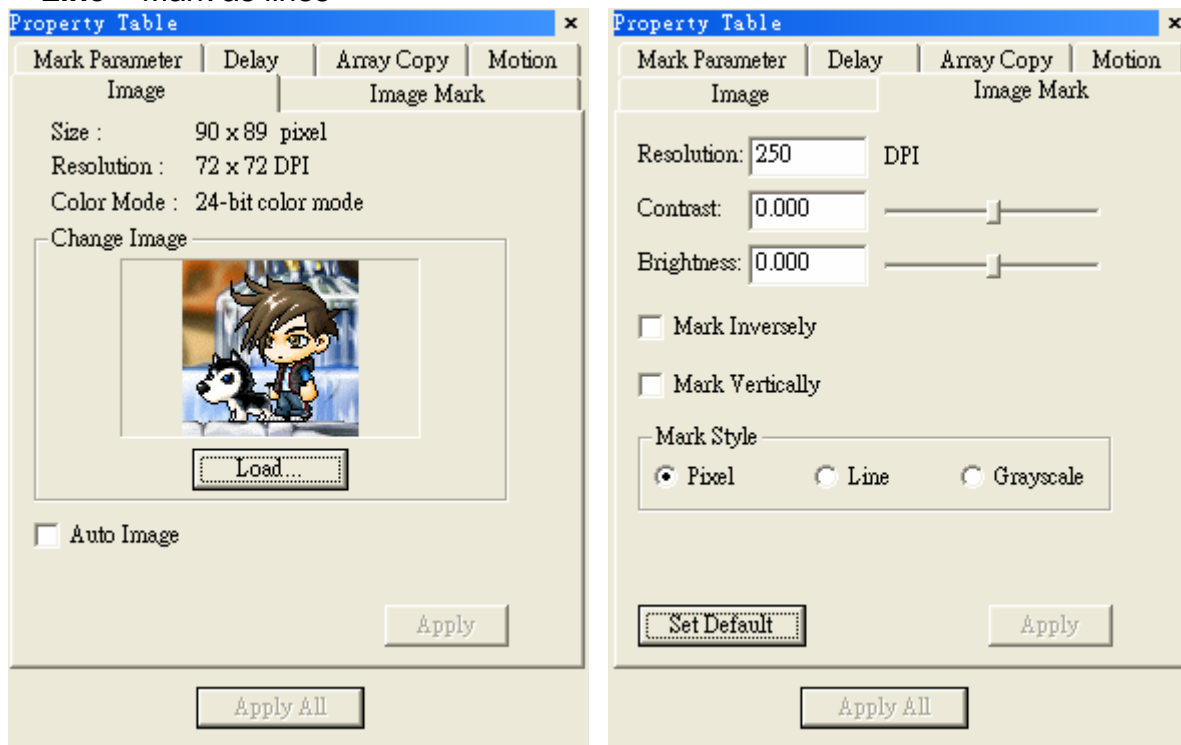

MarkingMate

6.3.8 Text

Create a Text object, and select it, and go the text page in the Property Table will be able to adjust the font style, font size and the oblique degree for the text.

If check the “**Auto Text**” checkbox, an “Auto Text Manager” page will show up for setting the Auto Text. (For detail descriptions please refer to **section 2.5.2.1 Auto Text Setting.**)

If click the “**Advanced**” button will enter a page of “Text Advanced” for further setting of general text object and multi auto text as below:

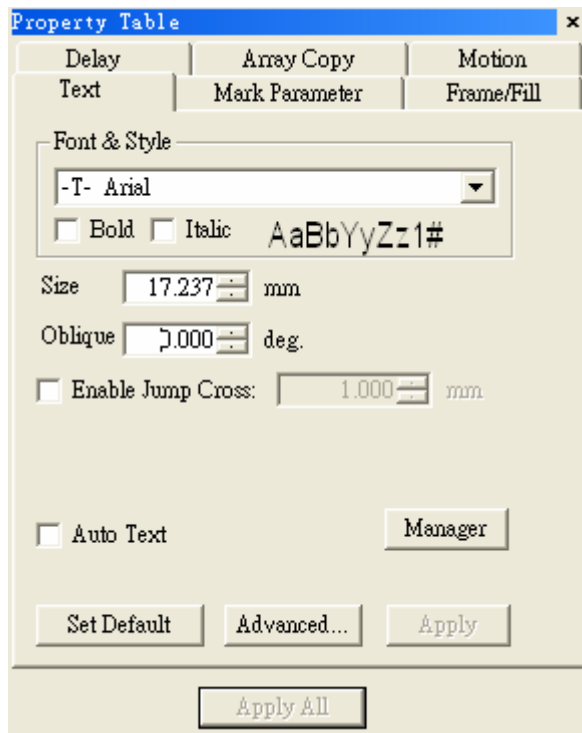

Text Advanced

Text pitch

Spacing between characters

Line pitch

Spacing between lines

Arrange

Horizontal or Vertical

Alignment

Alignment direction

Text

Welding:

Add

“Welding” function to

the overlapping part of the text.

Insert Auto Text Item:

For adding more than one Auto Text object (Please refer to **section 2.5.2.2 Multi Auto Text Setting.**)

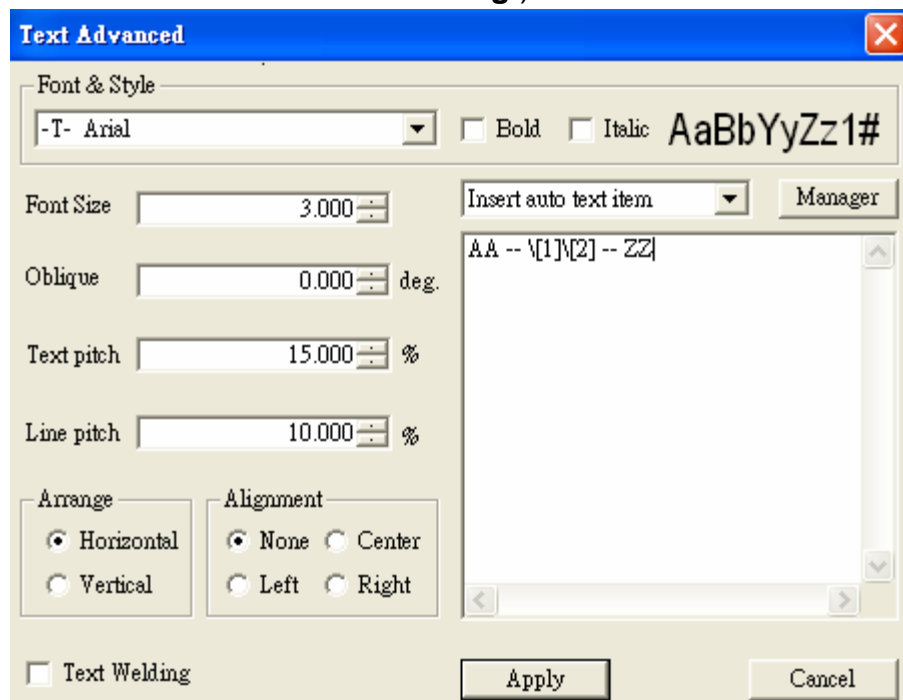

MarkingMate

6.3.9 Arc Text

Set the properties of the Arc Text

Center: center position

Radius: radius

Show Arc: show the path

Same as X Radius: the path will become a circle

Text Position: arrange the text position

Horz Offset: offset on horizontal direction

Baseline Offset: offset of the baseline

Close-to-Baseline: the text position related to the baseline

Reverse: the text will be arranged in reverse order

The image shows a 'Property Table' dialog box with several tabs: 'Frame/Fill', 'Delay', 'Array Copy', 'Motion', 'Text', 'Arc Text', and 'Mark Parameter'. The 'Arc Text' tab is selected. The dialog contains the following fields and controls:

- Center:** X: 12.333 mm, Y: -23.778 mm
- Radius:** X: 4.576 mm, Y: 4.576 mm
- Show Arc
- Same as X
- Text Position:** abc (dropdown menu)
- Horz. Offset:** 0.000 mm
- Baseline Offset:** 0.000 mm
- Close-to-Baseline:** Ajc (dropdown menu)
- Reverse
- Buttons:** Set As Default, Apply, Apply All

MarkingMate

6.3.10 Baseline

There are two baseline types when the selected text is arranged along a designated path. When you finished the editing, you have to press the Apply button.

Baseline-type: closed
For example: Rectangle

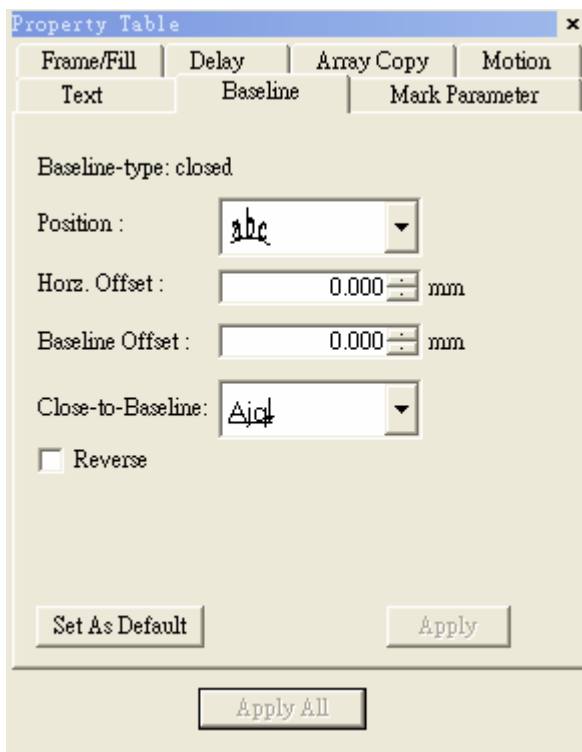

The screenshot shows the 'Property Table' dialog box with the 'Baseline' tab selected. The 'Baseline-type' is set to 'closed'. The 'Position' dropdown shows 'abc'. The 'Horz. Offset' and 'Baseline Offset' are both set to 0.000 mm. The 'Close-to-Baseline' dropdown shows 'A|c|'. There is an unchecked 'Reverse' checkbox. At the bottom, there are buttons for 'Set As Default', 'Apply', and 'Apply All'.

Baseline-type: open
For example: Curve

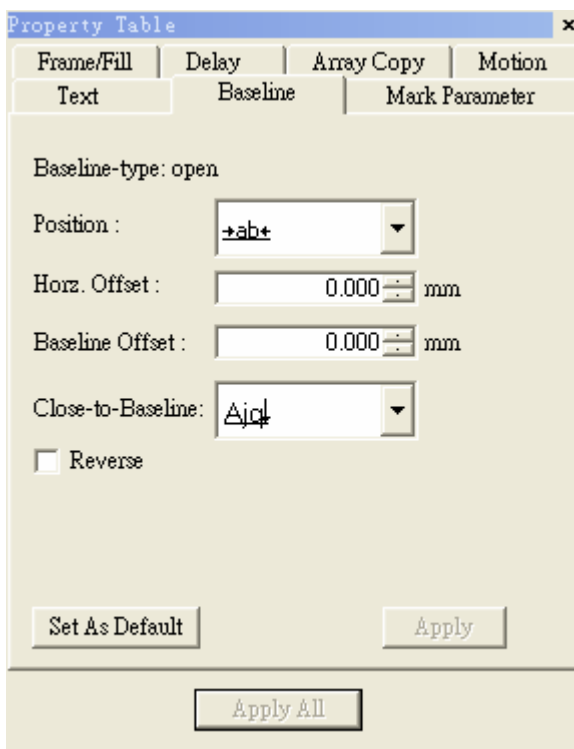

The screenshot shows the 'Property Table' dialog box with the 'Baseline' tab selected. The 'Baseline-type' is set to 'open'. The 'Position' dropdown shows '+abc+'. The 'Horz. Offset' and 'Baseline Offset' are both set to 0.000 mm. The 'Close-to-Baseline' dropdown shows 'A|c|'. There is an unchecked 'Reverse' checkbox. At the bottom, there are buttons for 'Set As Default', 'Apply', and 'Apply All'.

MarkingMate

6.4 Layer-related

When a layer object in the Object View being selected, the property table of this layer object will be displayed. Users can set up some output related parameters in the dialogue box; mainly include the I/O signal and etc.

6.4.1 Layer

This function allows you to set up the parameters of the layer include its name, color, view enable, edit enable, and output enable.

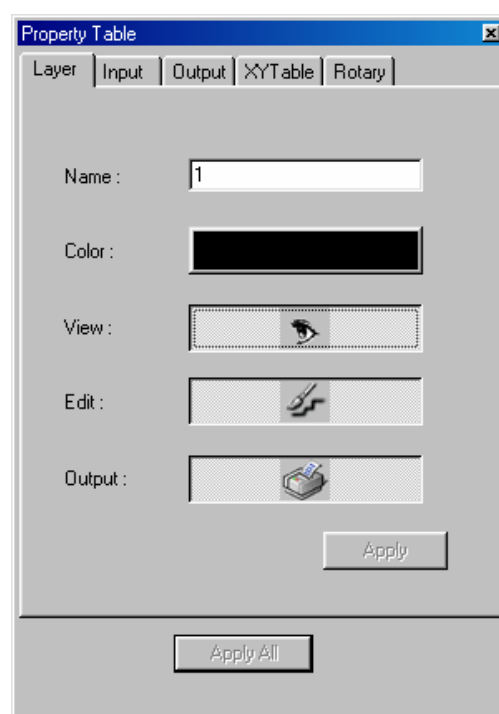

MarkingMate

6.4.2 Input

This function allows you to set up the input status of the layer. The system will first check the Input settings and then the Graph Setup.

Input Status

High or low voltage of the input points

Timeout

Waiting time

-1 means no limitation

Wait Input

Wait until all input status exist, otherwise wait for Timeout

Match Input

Wait until all input status exist, otherwise skip the layer

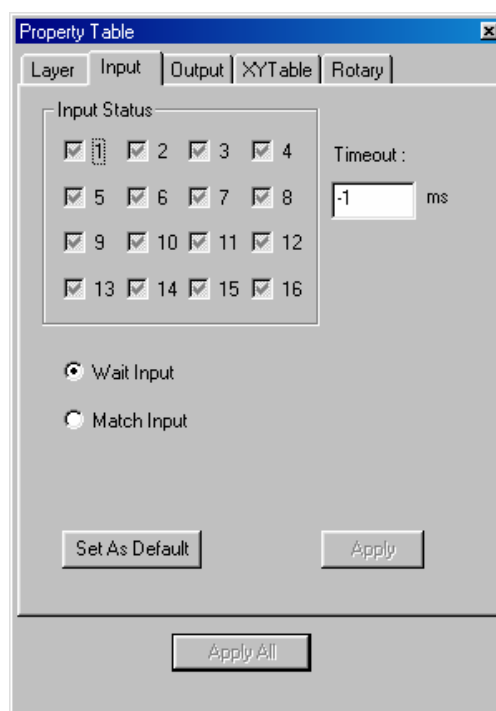

6.4.3 Output

Use this function to set up the output status of the layer.

The system will first handle the graph and then the output status.

Output Status

High or low voltage of the output points

Auto Clear Signal

Auto clear signal after the voltage settings are done

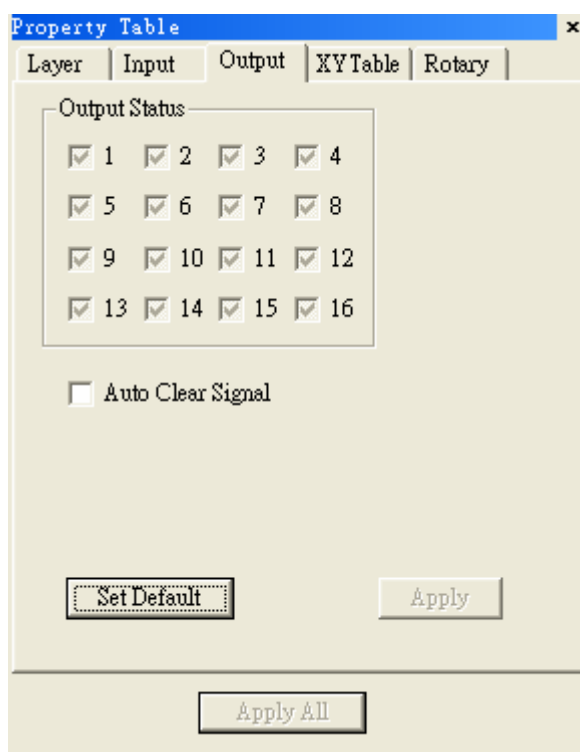

MarkingMate

6.4.4 XY Table (optional)

Enable

Enable the XY Table

Y Disable

Single axis marking

XY Coordinates

The coordinates value of XY

Table position

Add/Edit/Delete/Delete All/

Move Up/Move Down/Array

Copy

Allow users to edit the XY coordinate value

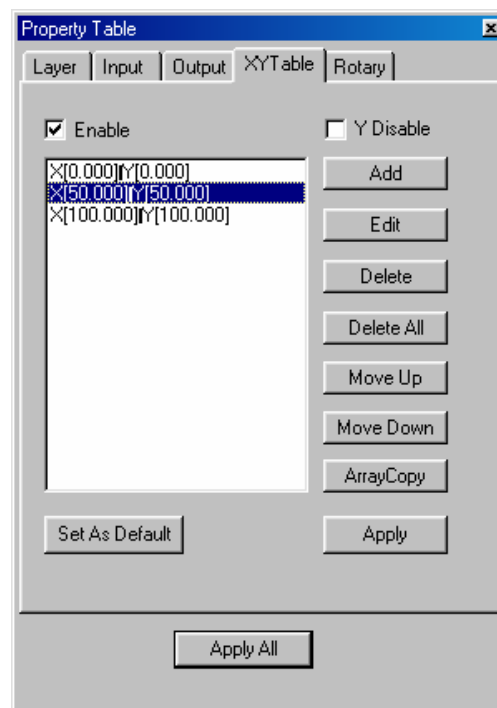

Add/Edit XY Table Position

Add or edit the XY table position which will be marked

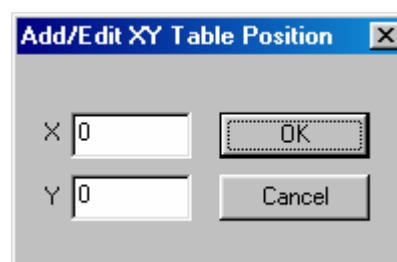

Layer Array Copy

This function allows users to add multiple points at one time

Insert Point: the position starting array copy

Count: copy amount

Pitch: the interval between the two points

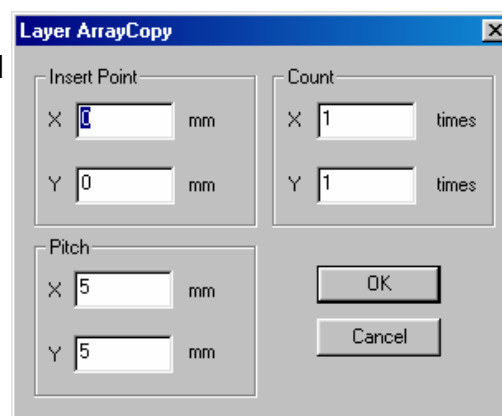

MarkingMate

6.4.5 Rotary (optional)

Enable

Enable the Rotary function

Method

Cylinder

Option –

Diameter: the diameter of the object

Max Width: the max acceptable width for rotary

Disc

Option –

Step Angle: the rotary angle per step

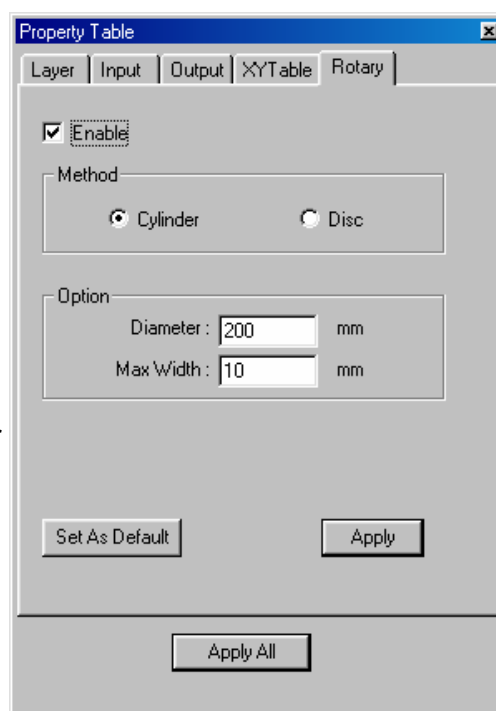

Chapter 7 Popup Menu

Click the right button of the mouse will display a quick view menu. When Show Order in View Menu is activated, user can change the mark order. And when the object has been transferred to curve (in Edit Menu), user is able to Add Vertex to the object.

The popup menu is different when you select different objects.

7.1 General Object

Select a general object and click the right button of the mouse, you will see the popup menu as below:

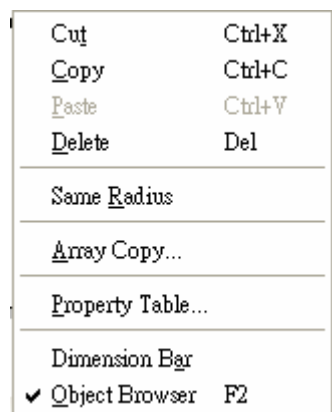

Cut	Remove selected data and store it in the clipboard for future use	Refer to section 4.2.3
Copy	Duplicate selected data and store it in the clipboard for future use	Refer to section 4.2.4
Paste	Attach data from the clipboard to the current document	Refer to section 4.2.5
Delete	Delete and remove the selected data	Refer to section 4.2.6
Same Radius	Make the circle object become the same radius	Refer to section 4.3.4
Array Copy	Execute the array copy function	Refer to section 6.2.4
Property Table	Show the Property Table of the object	Refer to section 6.2
Dimensional Bar	Enable/disable Dimension bar	Refer to section 4.7.7
ObjView Bar	Enable/disable Object Browser	Refer to section 4.7.4

MarkingMate

7.2 Curve

Select a curve you drew or the curve transferred from objects, and click the right button of the mouse; you will see the popup menu as below:

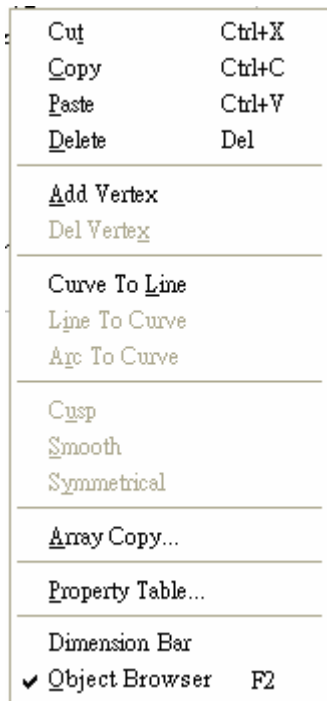

7.2.1 Add Vertex

This function allows you to modify a curve object; more vertexes will be more convenient to change the shape of the curve.

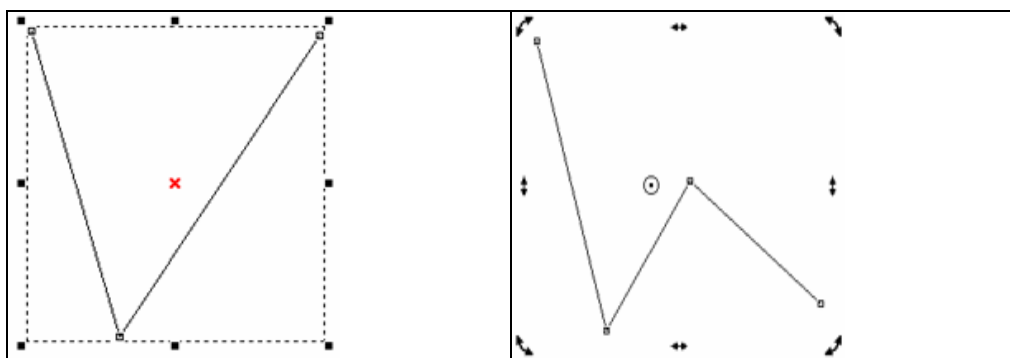

MarkingMate

7.2.2 Delete Vertex

Using “Delete Vertex” function will decrease the control points as below:

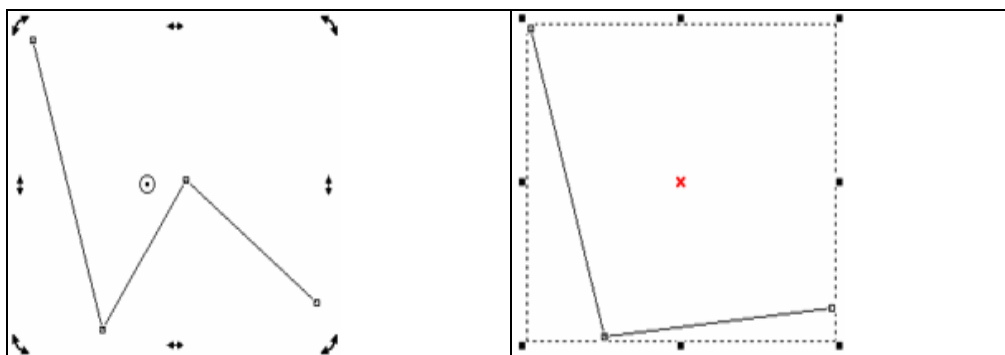

7.2.3 Curve to Line

Select “Curve to Line” function; the curve has been transferred to a line segment and lost its control points as below:

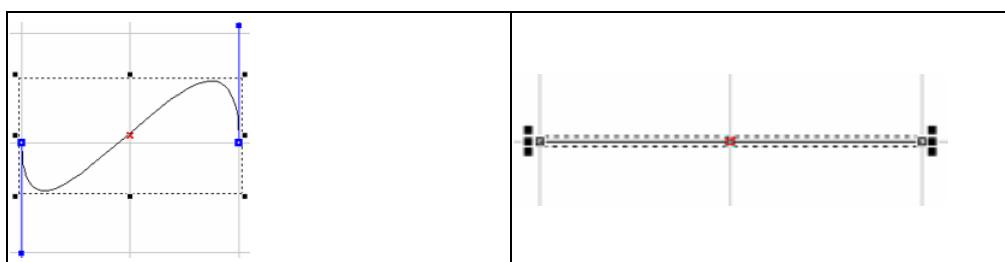

7.2.4 Line to Curve

Select “Line to Curve” function; the line segment has been transferred to a curve and its control points appeared as below:

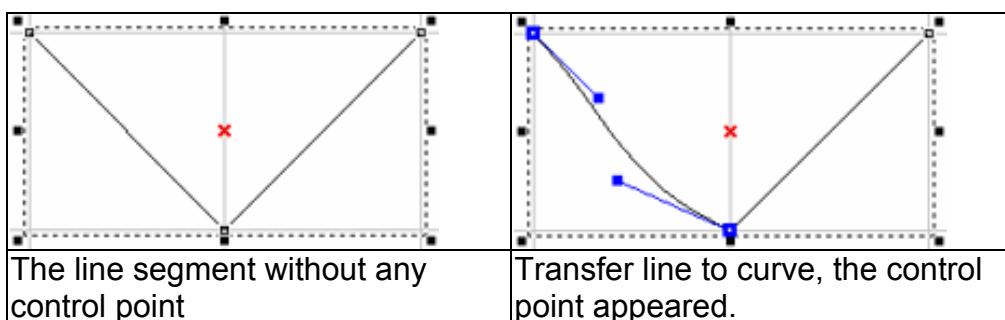

7.2.5 Arc to Curve

To use this function, you must first create an object and transfer the object to curve, and then click right button of the mouse to select the “Arc to Curve” function. This function allows you to add more vertexes to the curve as below:

MarkingMate

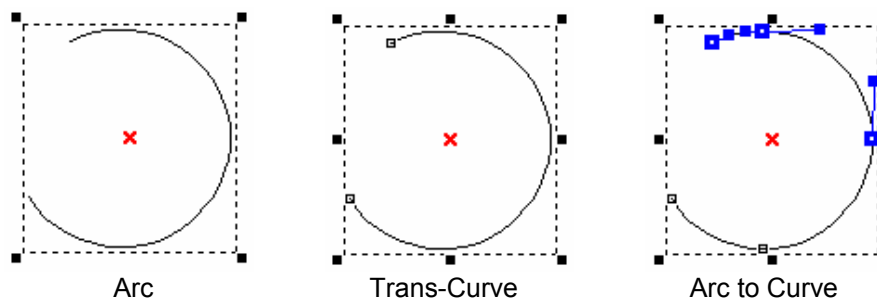

7.2.6 Cusp

The control points of the curve were smooth at the beginning; select “Cusp” function on the popup menu; the two sides of control points become independent as below:

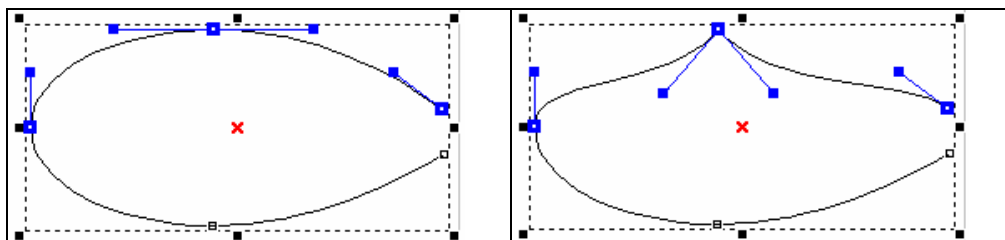

7.2.7 Smooth

The control points of the curve were cusp at the beginning; select “Smooth” function on the popup menu; the two sides of control points become smooth and dependent on each other as below:

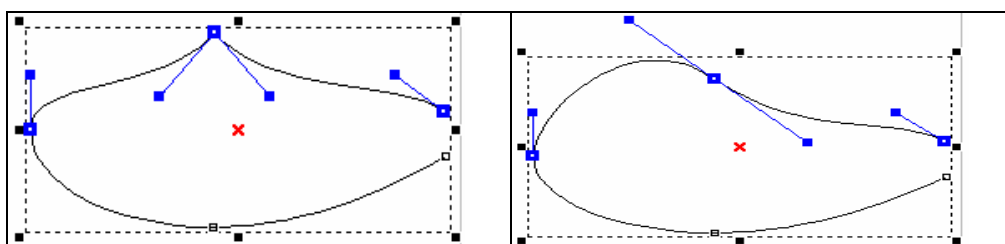

7.2.8 Symmetrical

The control point was smooth but not symmetrical; select “Symmetrical” function on the popup menu and move one of the control point; the other side of control point will move symmetrically as below:

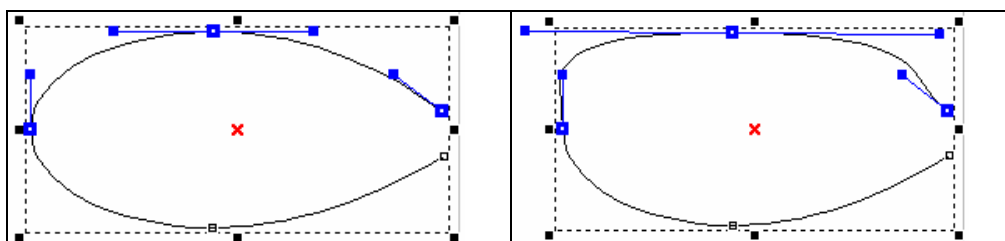

MarkingMate

7.3 Show Mark Order of a General Object

If the “Show Order” function in View Menu is activated, select a general object, and click the right button of the mouse, you will see as below:



7.4 Show Mark Order of a Curve

If the “Show Order” function in View Menu is activated, select a curve you drew or the curve transferred from objects, and you will see the below popup menu as you click the right button of the mouse:

MarkingMate

<u>C</u> ut	Ctrl+X
<u>C</u> opy	Ctrl+C
<u>P</u> aste	Ctrl+V
<u>D</u> elete	Del
<hr/>	
<u>T</u> op	
<u>U</u> ndermost	
<u>U</u> pper	
<u>L</u> ower	
<hr/>	
In Front Of...	
In <u>B</u> ack Of...	
<hr/>	
<u>R</u> everse	
Shortest <u>H</u> orizontal	
Shortest <u>V</u> ertical	
Shortest Distance	
<hr/>	
<u>A</u> dd Vertex	
Del Vertex	
<hr/>	
Curve To <u>L</u> ine	
<u>L</u> ine To Curve	
<u>A</u> rc To Curve	
<hr/>	
<u>C</u> usp	
<u>S</u> mooth	
Symmetrical	
<hr/>	
<u>A</u> rray Copy...	
<hr/>	
<u>P</u> roperty Table...	
<hr/>	
Dimension Bar	
✓ <u>O</u> bject Browser	F2

Chapter 8 Hot Key

File Menu	
Ctrl + N	Create a new document
Ctrl + O	Open an existing document
Ctrl + S	Save the current document using the existing file name
Ctrl + I	Import
Ctrl + P	Print
Edit Menu	
Ctrl + Y	Replace a cancelled action
Ctrl + Z	Cancel un unwanted action
Ctrl + X	Remove the selected object and place it in the clipboard
Ctrl + C	Duplicate the selected object and place it in the clipboard
Ctrl + V	Place the data on the clipboard on to the document
DEL	Delete the selected object
Ctrl + K	Combine
Ctrl + B	Break
Ctrl + M	Group
Ctrl + Q	UnGroup
Ctrl + H	Mirror Horizontal
Ctrl + L	Mirror Vertical
Ctrl + E	Baseline
Ctrl + D	Split
Ctrl + U	Transfer to a curve
Ctrl + A	Trimming
Ctrl + G	Welding
Ctrl + W	Contour
Execute Menu	
F5	Marking
F6	Quick Mark
F7	Dry Run
F10	Close Dialogue Box of Marking, Quick Mark, and Dry Run
Others	

MarkingMate

F1	Open HELP
F2	Open the Object Browser
Shift+F2	Move the Object Browser to the lower left corner
F3	Open the Dimension Bar
F4	Open the User Level dialogue box
Ctrl + F4	Close the current file
Ctrl + F6	Switch to another opened file
Ctrl	1. Force the angle of a line segment to be 15°when drawing a line, and force the width equal to the height when drawing an arc, circle, or rectangle. 2. The XY axis of the object will be adjusted simultaneously
Ctrl + T	Open the Property Table
Shift	The center of a circle or rectangle will be the center of the initial axis The XY axis of the object will be adjusted simultaneously
Tab	Select object by marking order
C	When you are drawing lines, arcs, and curves, press C key will make the continuous segments become a closed loop.
X/Y	Set the start point or end point of the object

MarkingMate

Appendix A: Driver Manager

Users are allowed to change drivers they need as their motion card changed. Whenever driver being changed, the system must be restart.

Click [Start - Program] from the left-bottom of the window and select **Driver Manager** from the MarkingMate System directory as below to change the driver you want.

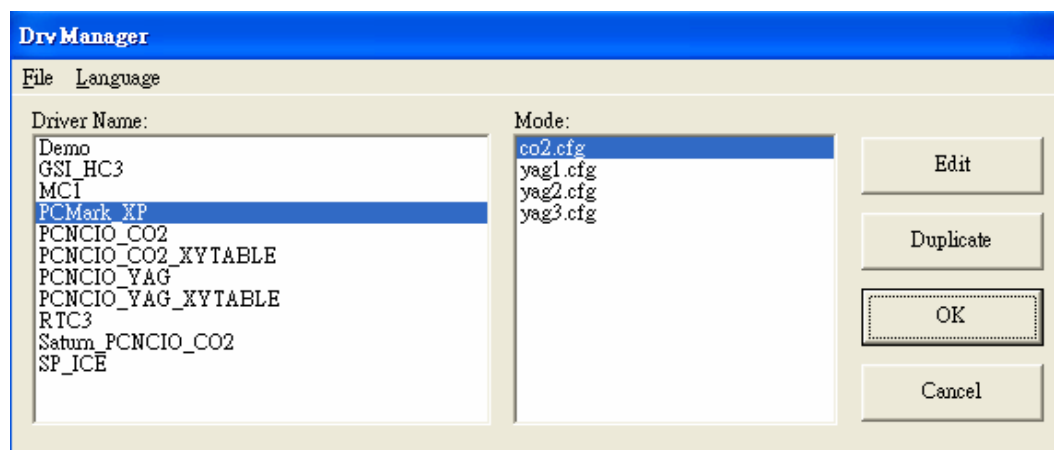
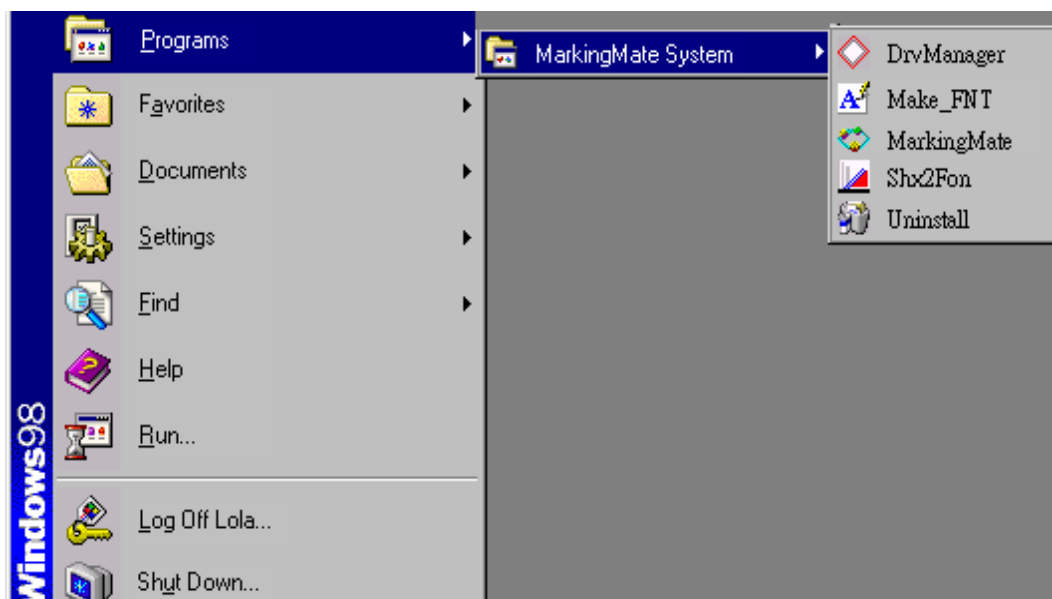

Make_FNT

Appendix B: Make_FNT





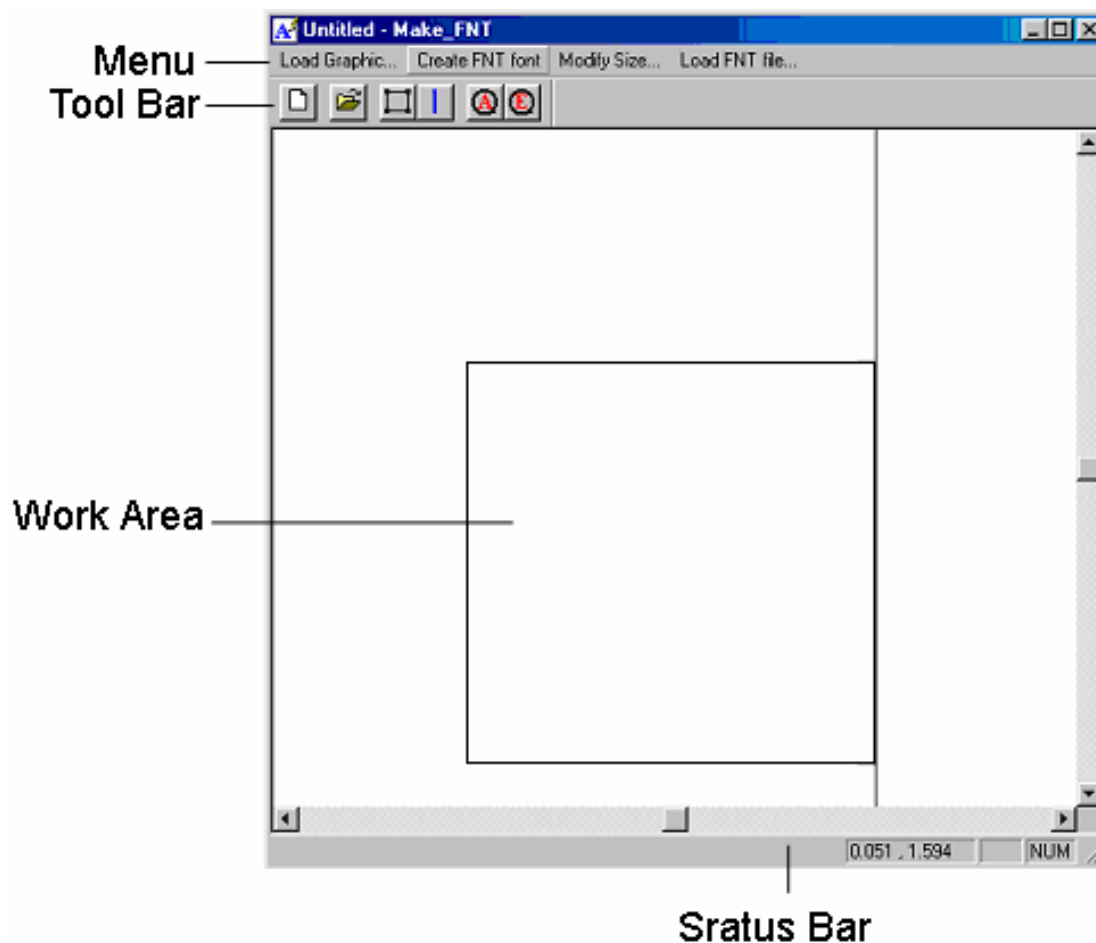

Make_FNT is a subsidiary program of MarkingMate. After finishing MarkingMate installation, the Make_FNT program is available to use.

Make_FNT is a program allowing users to create fonts for MarkingMate. Users can copy the fonts created in **Make_FNT** to the directory of MarkingMate\fonts, and the fonts are ready for MarkingMate.

1. User Interface



Make_FNT

Introduction of Make_FNT interface:			
Menu Bar	Load Graphic	Load a DXF file for editing.	
	Create FNT font	Create new FNT font files.	
	Modify Size	Modify the position and size of the font file you loaded.	
	Load FNT file	Load a FNT file for editing.	
Toolbar		Load Graphic	Load a DXF file for editing.
		Create FNT font	Create new FNT font files.
		Modify Size	Modify the position and size of the font file you loaded.
		End Line	The end position of the character.
		Zoom All	See all of the Work Area.
		Zoom Extend	See all of the objects.
Work Area	The area for editing.		
Status Bar	The command notes and mouse position will be displayed in the Status Bar.		

Make_FNT

2. How to use Make_FNT

To create fonts in **Make_FNT**, users have to prepare some DXF files first. You can use AutoCAD or CorelDRAW to create a DXF file, import the DXF file into Make_FNT program, adjust its size, spacing, or other changes you need and then save it as a FNT font file.

The flow chart of executing the program is as below:

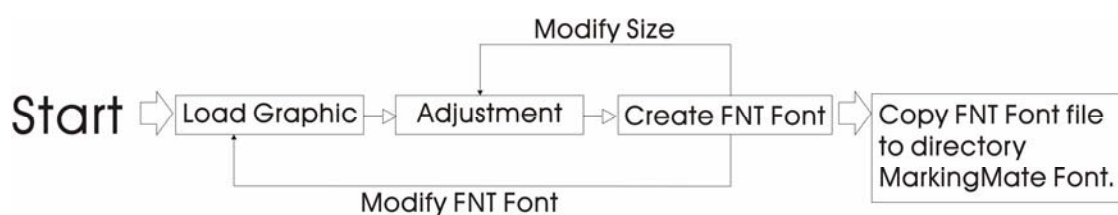

2.1 Start the program

You can start the program by clicking “Start – Program” and select the Make_FNT program as below.

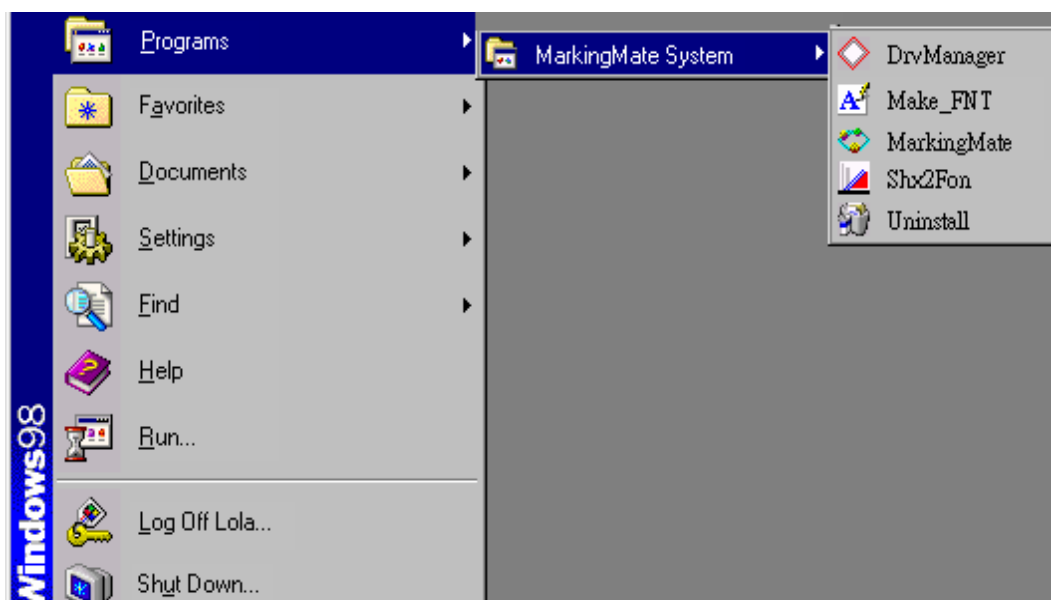

2.2 Load Graphic

Use AutoCAD or CorelDRAW to create some DXF files you need.

Make_FNT

Click “Load Graphic” from the Menu Bar or click the  button from the toolbox, a dialogue box will be displayed.

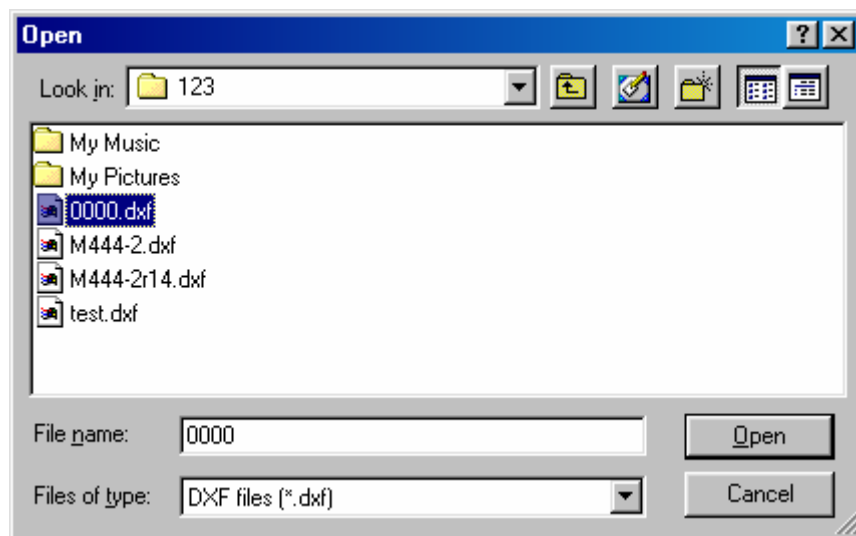

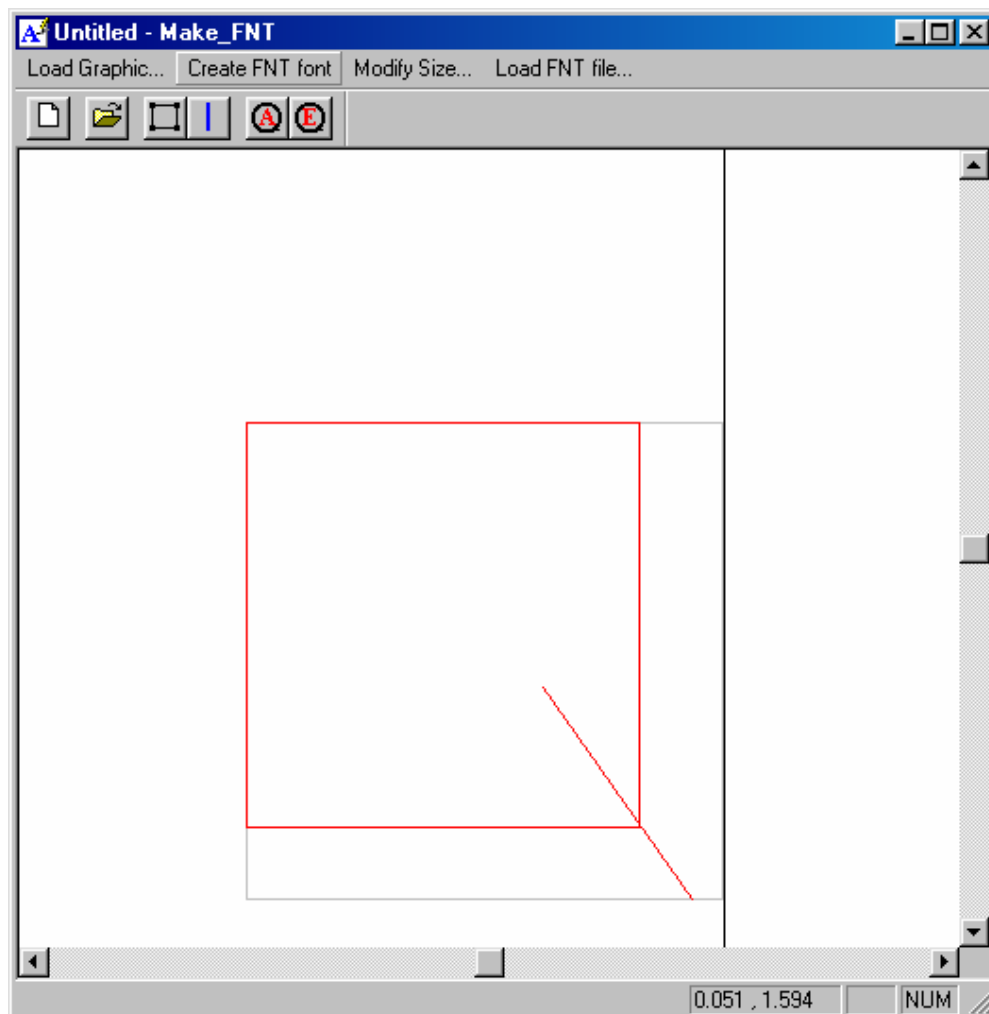

Select the DXF file you want and then click the “Open” button.
The selected picture will be displayed in the Work Area.



Make_FNT

2.3 Adjustments

Click “Modify Size” from the Menu Bar or click  button from the Toolbar to adjust the position and scale of the font. And then click the  button from the Toolbar to adjust the end line of the character.

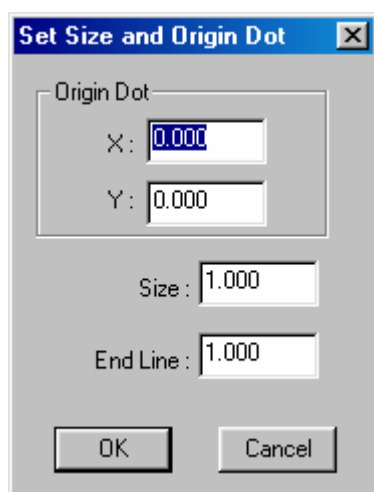

- Origin dot** Set the position of the origin dot
- Size** Set the object size
- End Line** Set the end line of the object

2.4 Create FNT Font

After finishing the adjustment, click “Create FNT Font” from the Menu Bar or click the  button from the Toolbar, a dialogue box will be displayed as below:

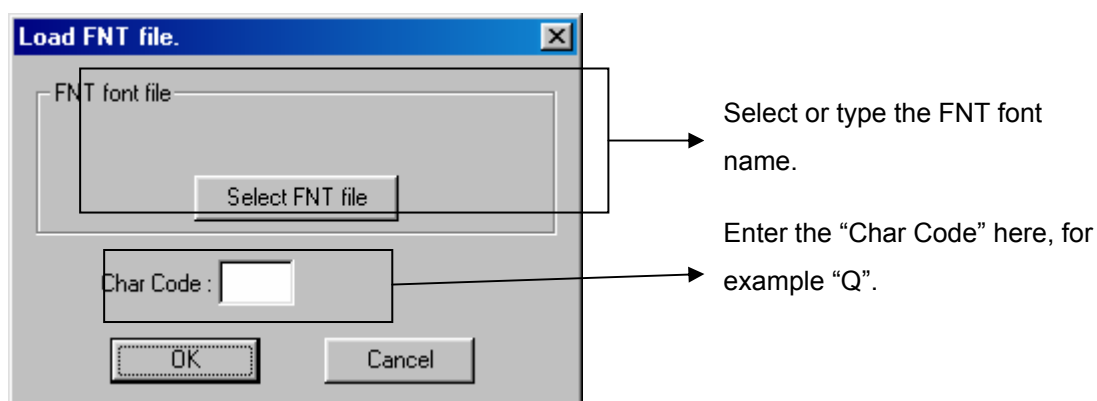

Make_FNT

Click the “Select FNT Font” button, select or enter the file name you want. Enter the character code you want in the box of “Char Code” and then press “OK”.

Move or copy the new FNT font file to the directory of MarkingMate\Font and then this new font is available for MarkingMate program.

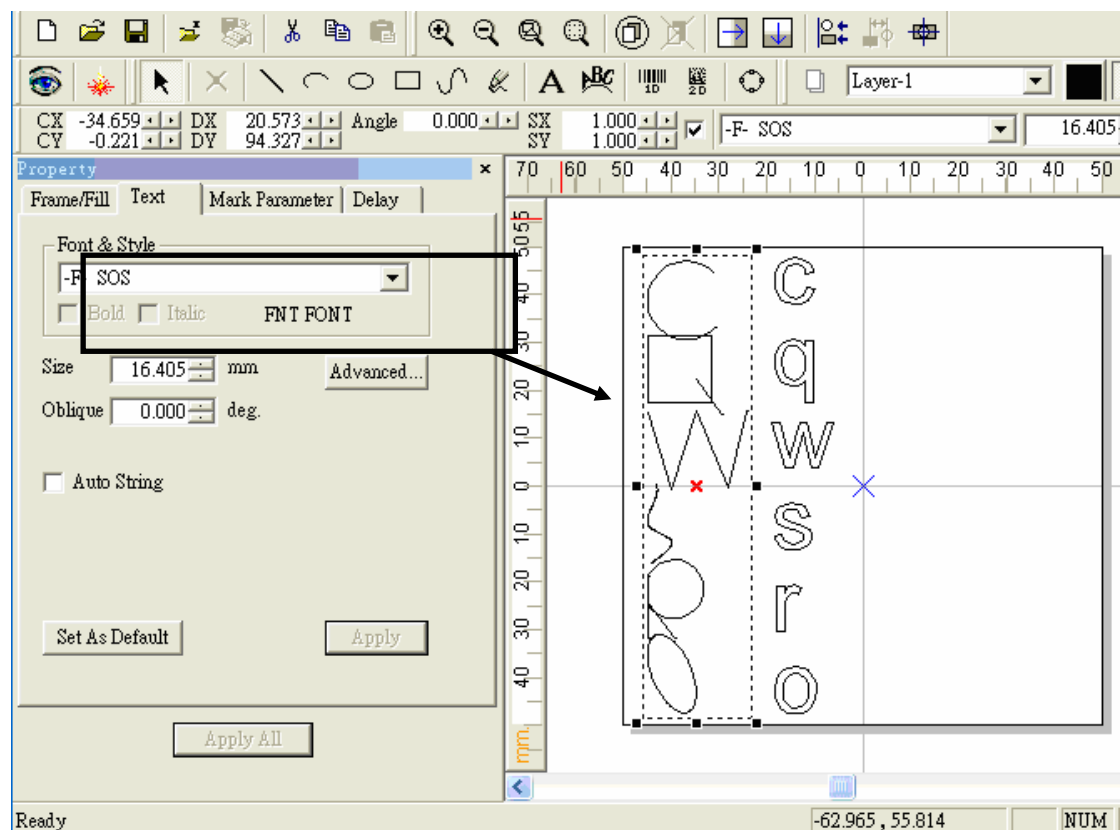

2.5 Modify FNT Font

If you want to modify the FNT font you have created, click “Load FNT font” from the Menu Bar, a dialogue box as below will be displayed:

Make_FNT

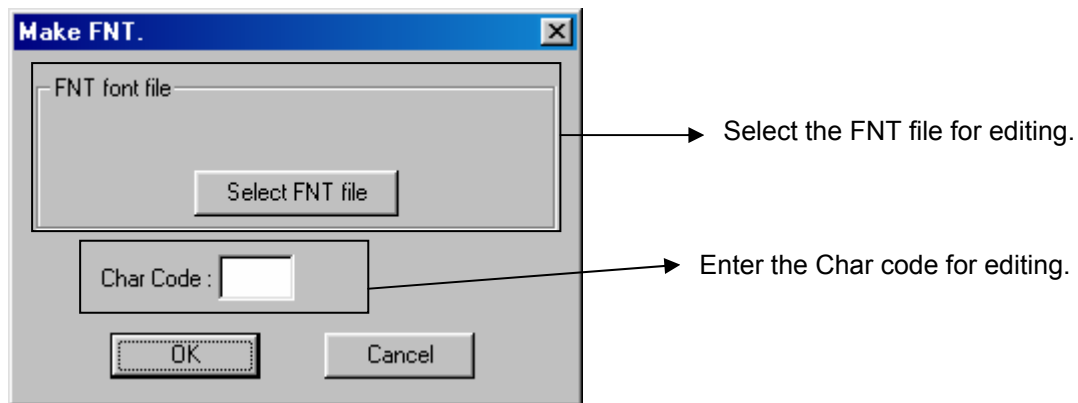

Click the button of "Select FNT file" and select the file you want.

Enter the Char Code you want and press "OK", and then you are able to do the adjustments as the description on section 1.3.

After finishing the adjustments, repeat the action as section 1.4 to save the file.

SHX to FON

Appendix C: SHX to FON

SHX to FON is another subsidiary program of MarkingMate. This program is able to convert the font format from **SHX** to **FON**.

Method:

Click “Start – Program” and select “SHX to FON” to enter this program as below.

Set the file directory path of FON fonts.

Click the “Add” button to select the files for convert. You can convert many files at the same time.

If you want to remove some files from the convert list, select the file first and then click the “Remove” button to delete it.

After all the SHX files for convert have been added in the list, press the “Convert” button and the convert result will be displayed in the bottom of this dialogue box.

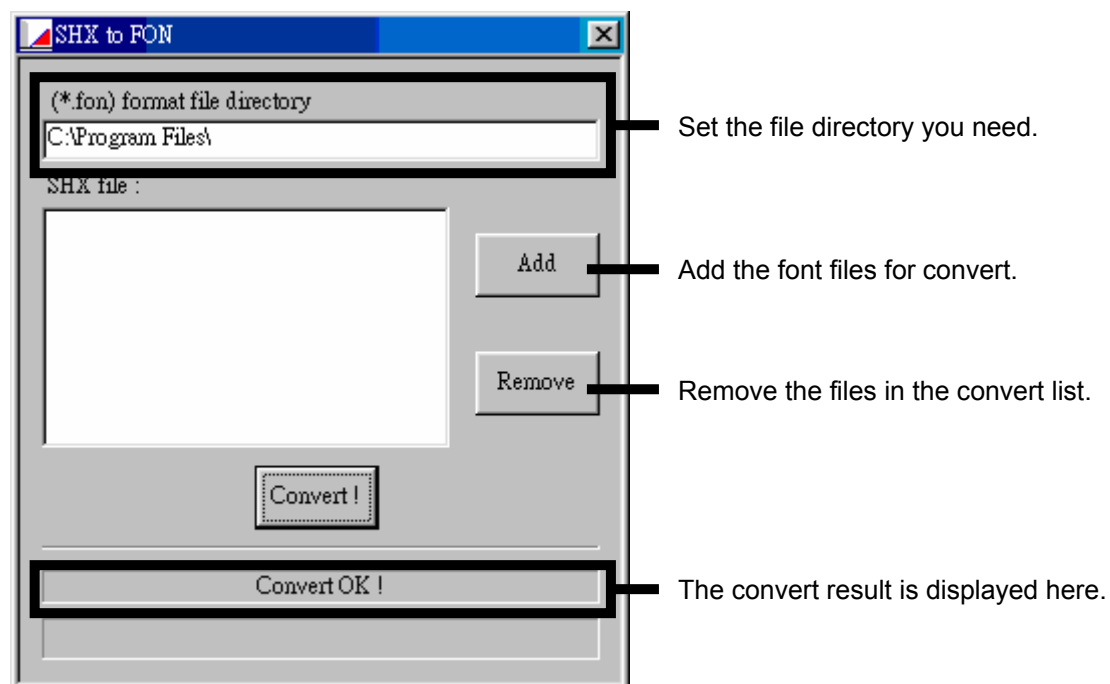

Config.ini

Appendix D: Config.ini

Config.ini is a setting file in the directory of C:\Program Files\MarkingMate. In general situation, user does not have to modify this file unless some special cases. If you need to modify this file, just simply open the file, change the settings, save the file, and then restart the MarkingMate program. The more detail description will be listed as below:

[ENV]	System Environment Parameters
MachineChk= 0	Automation (0: Disable, 1: Enable)
MachineChk_ShowMessage=1	Show error message (0: Disable, 1: Enable)
VariablePolyDelay= 0	The Mid Point Delay time will be changed in accordance with angle (0: Disable, 1: Enable)
AutoTextMode=1	Auto Text Mode (0: Disable, 1: Enable)
Jump_Min_Delay=0.0	Delay time for Jump (ms)
Jump_Limit_Length=0	Limited movement (mm)
MarkThreadEnable=1	Enable the Mark Thread (0: Disable, 1: Enable)
[Rotary]	Rotary Axis Parameters
Enable=1	Enable (0: Disable, 1: Enable)
Calibration=1	Calibration (0: Disable, 1: Enable)
Ring=1	Ring Text (0: Disable, 1: Enable)
Cylinder=1	Cylinder (0: Disable, 1: Enable)
MotorSetup=1	Motor Setup (0: Disable, 1: Enable)
[MultiMarking]	Auto Marking Parameters
Enable=1	Enable (0: Disable, 1: Enable)
Delay=0	Delay Time (sec)
[LogFile]	Log File Parameters
Enable=0	Enable (0: Disable, 1: Enable)
KeepRow=10	Log Rows
LogMarkDialog=1	Log Mark Dialogue (0: Disable, 1: Enable)
StartTime=0	Log Start Time (0: Disable, 1: Enable)
Path=	Log Path
[Application]	Application related parameters
ShowLaserPanel=0	Show Laser Panel (0: Disable, 1: Enable)
	
ShowHatch=1	Show Hatch function (0: Disable, 1: Enable)
[IO_INPUT]	Input point related parameters
INPUT01= 01,01	Input No.= Display Name, Description (See below figure)
INPUT16= 16,16	Input No.= Display Name, Description (See below figure)

Config.ini

[IO_OUTPUT]	Output point related parameters
OUTPUT01= 01, 01	Output No.= Display Name, Description (See below figure)
OUTPUT15= ME, Mark End	Output No.= Display Name, Description (See below figure)
[MarkAndPrint]	Mark & Print Parameters
Enable=0	Enable (0: Disable, 1: Enable)
FeedUp=0	Rows for moving ahead
FeedDown=10	Rows for moving follow-up
BarcodeHeight=130	Barcode Height (cm)
PrintAndCut=0	Print & Cut (0: Disable, 1: Enable)
[SignalRule]	Signal Parameters (refer to section 2.2.1)
Active_PR_MR=1	Program Ready/Mark Ready signal (0: Active Low, 1: Active High)
Active_ReadyStart=1	Ready for Start signal (0: Active Low, 1: Active High)
Active_ME=1	Mark End Signal (0: Active Low, 1: Active High)
Active_Shutter=1	Shutter Signal (0: Active Low, 1: Active High)
Active_Lamp=1	Lamp Signal (0: Active Low, 1: Active High)
Active_Align=1	Align Signal (0: Active Low, 1: Active High)
PR2MR=0	Change Program Ready Signal to Mark Ready Signal (0: Program Ready, 1: Mark Ready)
MarkEndPulseTime = 0	MarkEnd Signal keep high (sec) (0: default setting, means no pulse)
[MarkParmList]	Mark Parameters List
CurPath=E:\Program Files\MarkingMate\MarkParam	Current Path
[VERSION]	Version Parameters
Version=1000	Version

The Planning of Input/Output Point:

Open the MarkingMate software, go to the Property Table and select “Driver” label and then push the “I/O Test” button will see the figure as below:

Config.ini

The default setting about IO in Config.ini:

[IO_INPUT]

INPUT01= 01,01

INPUT02= 02,02

.....

INPUT15= 15,15

INPUT16= 16,16

[IO_OUTPUT]

OUTPUT01= 01,01

OUTPUT02= 02,02

.....

OUTPUT15= 15,15

OUTPUT16= 16,16

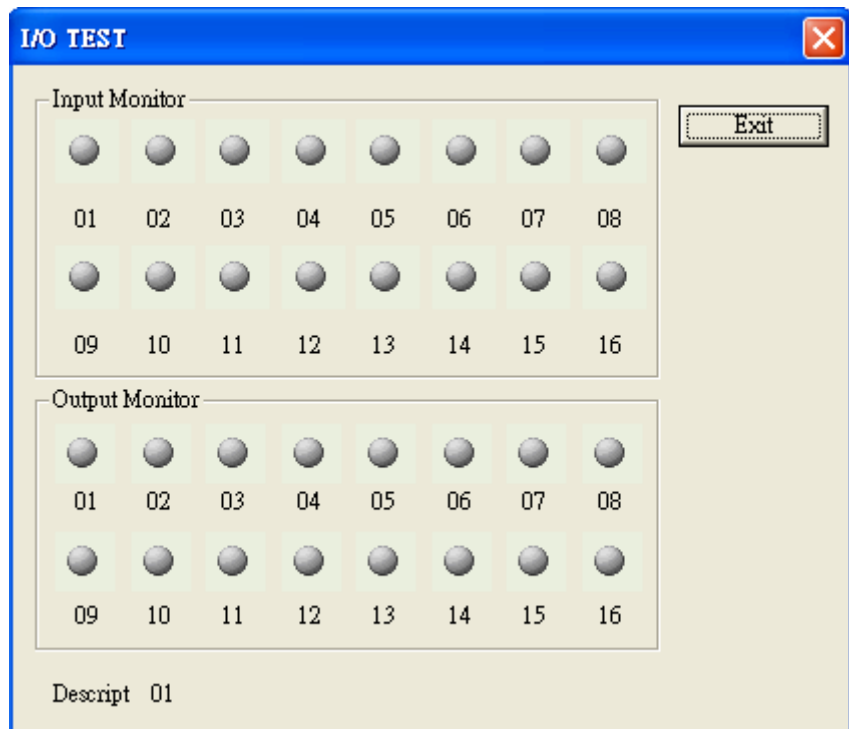

Change the setting as below in Config.ini will see the right figure:

[IO_INPUT]

INPUT01= 01,01

.....

INPUT15= Start,Start

INPUT16= Stop,Stop

[IO_OUTPUT]

OUTPUT01= 01,01

.....

OUTPUT14=

PR,Program Ready

OUTPUT15= ME,Mark End

OUTPUT16=

RdySt,Ready for Start

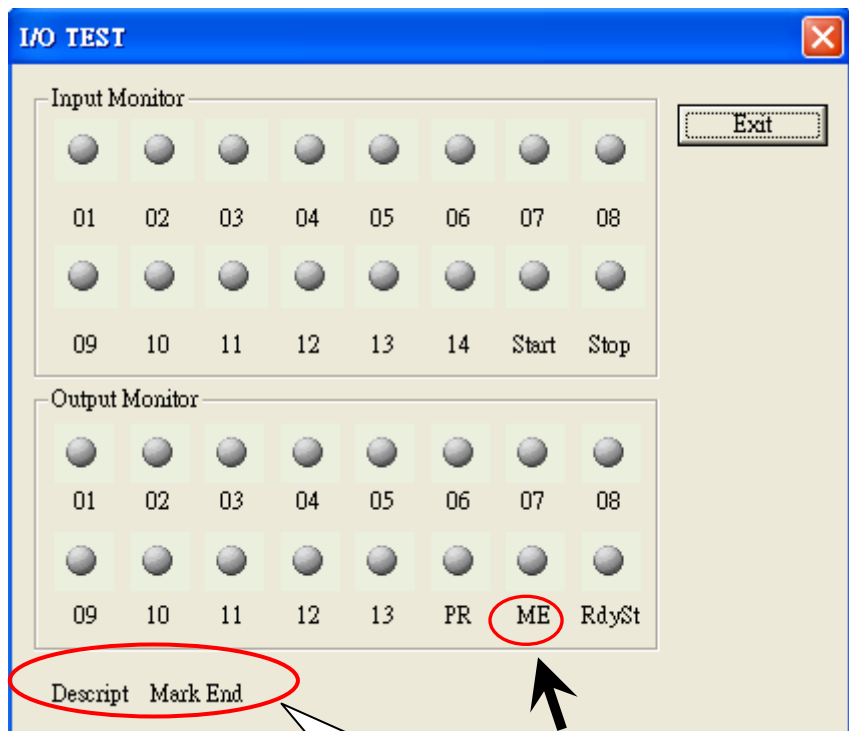

When mouse move to the position of I/O name (as arrow point), its description was shown as above.

MM.ini

Appendix E: MM.ini

There were some parameters in MM.ini can be modified but now they are all moved to the Config.ini. If you need to change them please see the detail description in Appendix D: Config.ini.

Auto Text – Serial No. Advance

Appendix F: Auto Text – Serial No. Advance

The settings of Auto Text – Serial Number are as the description of section 2.5.2.1. If users have special requirements for serial numbers, please select “Serial No. Advance”. Its settings are as below:

First create a text object in the Work Area, go to the Property Table to select “Auto Text” item, an Auto Text Manager will show up as below, then choose the Auto Text Mode as “Serial No. Advance”.

This function will engrave fixed and increasing numbers onto the marked object. Numbers inserted as **Prefix** and **Postfix** will represent the constant numbers engraved at the beginning and end of the serial number.

Content

Start: the beginning number. If checked “Auto cycle”, the number will repeat from this number when the end number has been completed.

Step: increment level of the increasing numbers.

End: the end number

Current: the first number to be marked when you execute marking. This number can be set as any between “Start” and “End” number.

Base: default setting is Decimal, push the button to do more special carry settings.

Digit: the total number of fixed number to be applied to the content portion. 0 means no limitation.

Lead: fill up characters. For example if 4 digits were selected, and leads 0, then 1 would be represented by 0001.

Repeat: repeat time for each number

Already repeated: already repeat time

Recycle: will repeat automatically from the start number once the end number has been completed.

For example: Start: 0, Step: 1, End: 9, Current: 5, Repeat: 3, Already repeated: 2, checked “Recycle”, then the mark result will be “5666777888999111...”.

The screenshot shows the 'Auto Text Manager' dialog box. At the top, there's a title bar with 'Auto Text Manager' and a close button. Below that, the 'Auto Text Item' section includes a dropdown menu set to 'Engine Item 1', a 'Rename' field with 'Engine Item 1', and 'Delete Item' and 'Create Item' buttons. The 'Auto Text Item Setting' section has a dropdown for 'Auto Text Mode' set to 'Serial No. Advance'. The 'Serial No.' section has a 'Prefix' field with '|'. The 'Content' section contains a grid of spinners: Start (0), Base (10), Step (1), Digit (0), End (9), Lead (empty), Current (5), Repeat (3), Recycle (checked), and Already repeated (2). At the bottom, there's a 'Postfix' field and a 'Close' button.

Mark on Fly

Appendix G: Mark on Fly

To have the function of “Mark on Fly”, users must have had the right settings on both MarkingMate software and MC-1 Controller. Its step is explained as follows:

1. Enable the “Mark on Fly” function of MC-1 controller.

- A. Click [Start - Program] from the left-bottom of the window and select “**Driver Manager**” from the MarkingMate System directory as below:

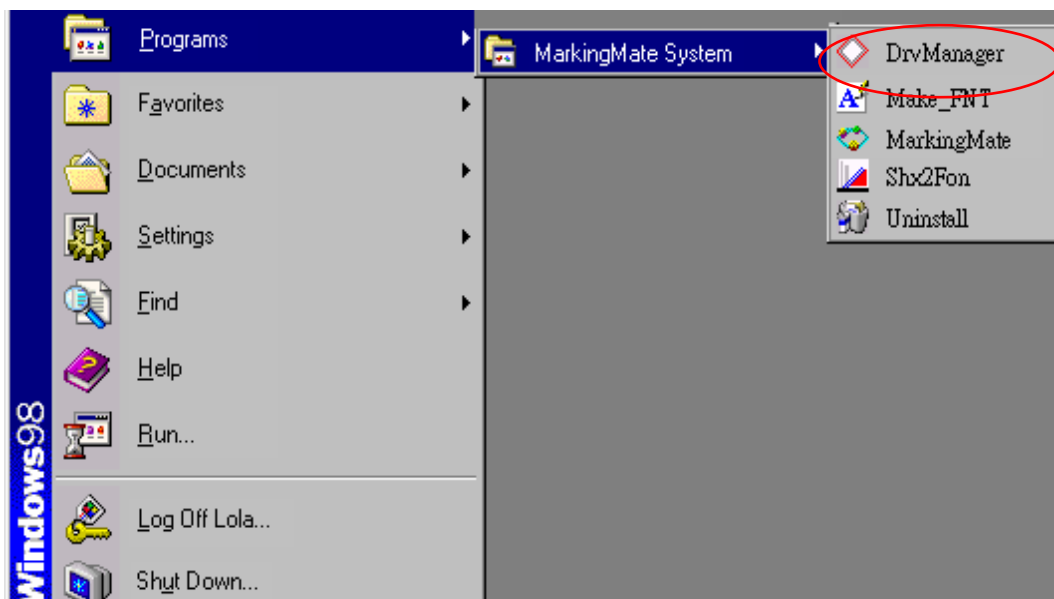

- B. Choose “MC1” in left column and select the correct driver (CO2 or YAG) and then click “Edit” button.

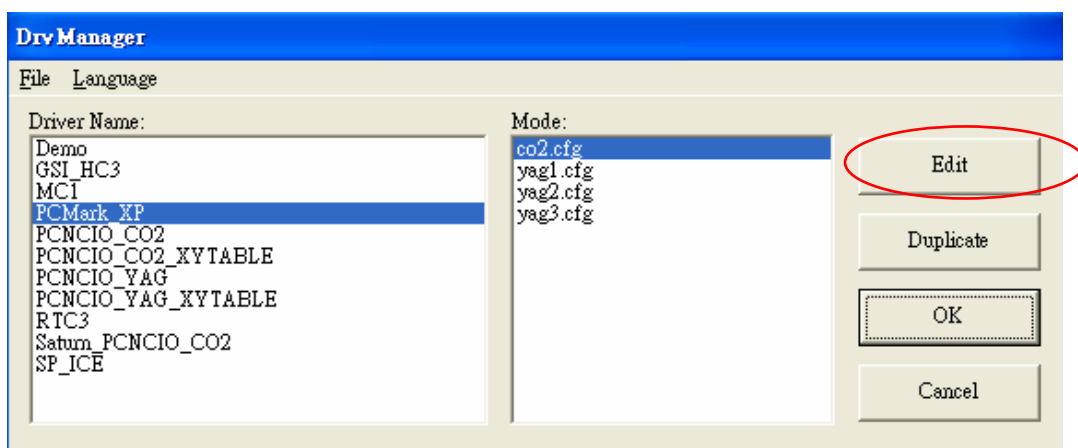

- C. Checked the item of “Enable Mark on Fly” in the Parameters Setting of MC-1 Controller as below and click “OK” button.

Mark on Fly

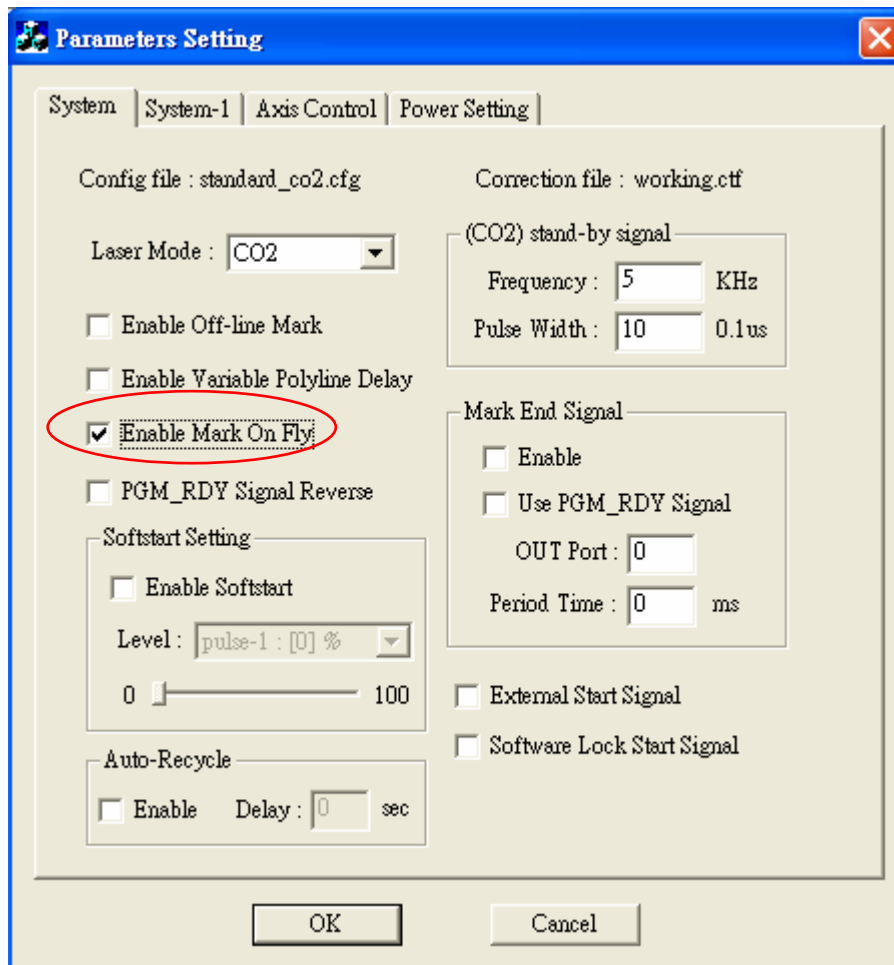

- Open the MarkingMate software, select “Global” from the “Property Table” as below. Enter the right parameters about “Mark on Fly”; push the “Apply” button and the setting is done.

Mark On Fly: It enables you to mark while the working pieces are moving. You can choose to use this function on X or Y Axis.

X/Y Encoder (no-checked):
Speed: speed of conveyer.
Delay: delay a giving count pulse then start marking.

X/Y Encoder (checked):
Factor: the value of conveyer moving per encoder count.
Delay: delay a giving count pulse then start marking.

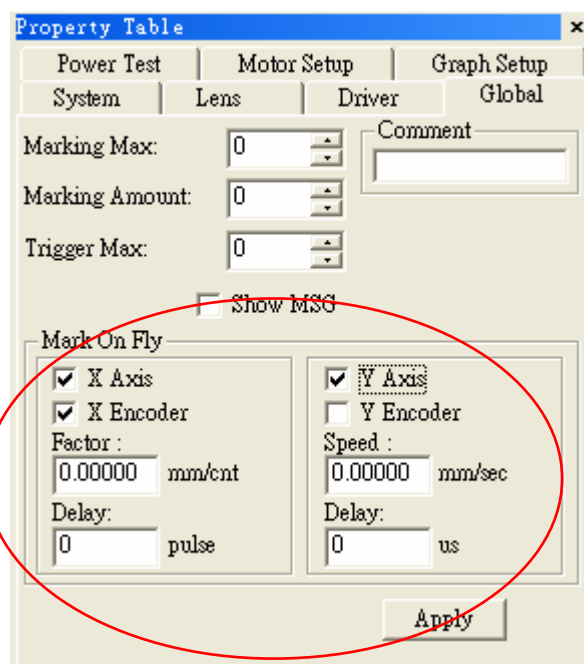

How to Control Align Light with MC-1

Appendix H: How to Control Align Light with MC-1

The default settings of align light control of MC-1 Controller is disabled. If users want to enable this function, must follow the steps as below:

1. In the directory of C:\Program Files\MarkingMate\Drivers\MC1\cfg, find a driver you used and open it (for example: standard_co2, standard_yag, or others). Modifies one of the line "Align_Out=0" to become "Align_Out=3". (0 means function disabled, 3 means the third output will be defined as align control.) There are total 16 outputs can be defined, please refer to the description of MC-1 controller user manual. Saved the file and then restart the MarkingMate software. Go to the "Property Table – Driver" page, and click "I/O Test" button, you will see a dialogue box as below that the third output is lighted. If you have connected the third output point of MC-1 controller to the

right position of the laser machine, then you can use the  button to control the align light in the software already.

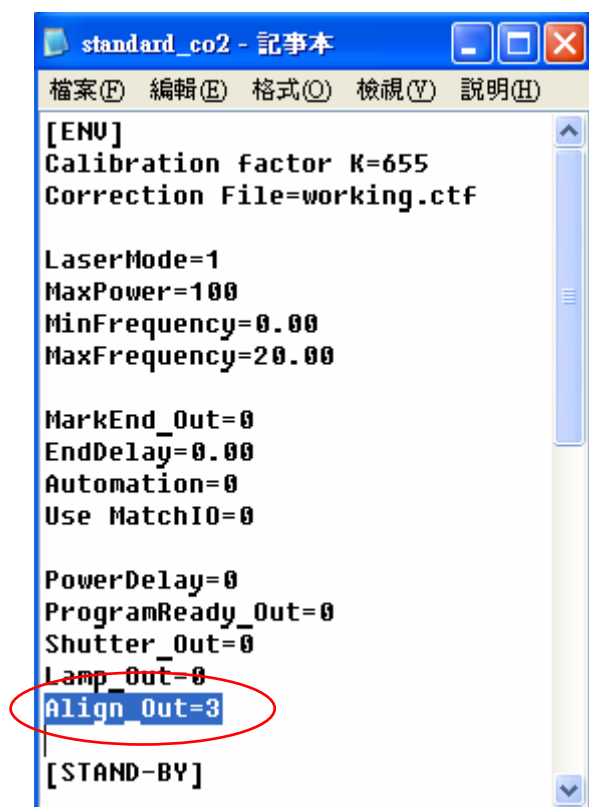

```
standard_co2 - 記事本
檔案(F) 編輯(E) 格式(O) 檢視(V) 說明(H)
[ENU]
Calibration factor K=655
Correction File=working.ctf

LaserMode=1
MaxPower=100
MinFrequency=0.00
MaxFrequency=20.00

MarkEnd_Out=0
EndDelay=0.00
Automation=0
Use MatchIO=0

PowerDelay=0
ProgramReady_Out=0
Shutter_Out=0
Lamp_Out=0
Align_Out=3
[STAND-BY]
```

How to Control Align Light with MC-1

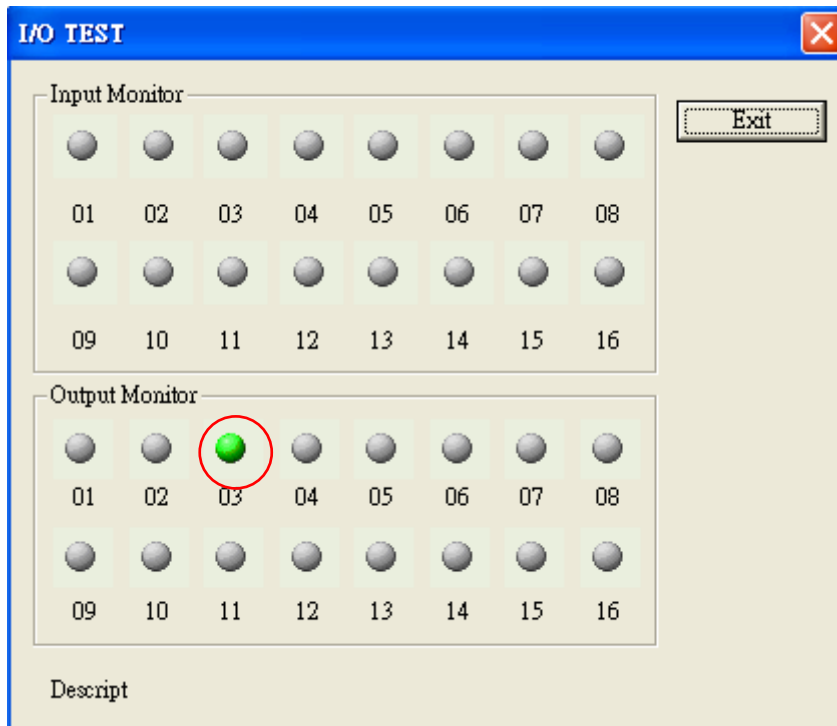
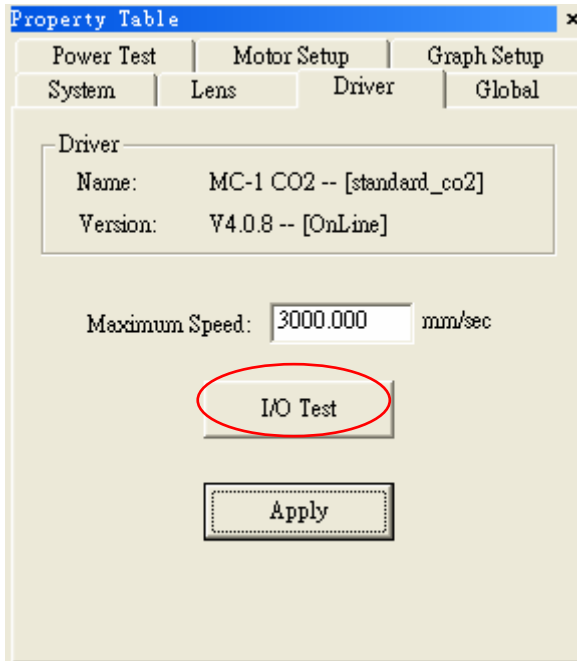

How to Control Align Light with MC-1

Marking...

Comment

Executing



Amount: 1 Current: 0.026 sec.

Total: 0.026 sec.



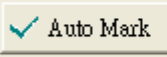

Marking Mode

All Selected

 Exec

 Auto Mark  Auto Home

 System Setting

     Exit

Object Name	Object Nick ...	Object Content	Type	Start	End
Rect	1				
Circle	2				
Text	3	0			